

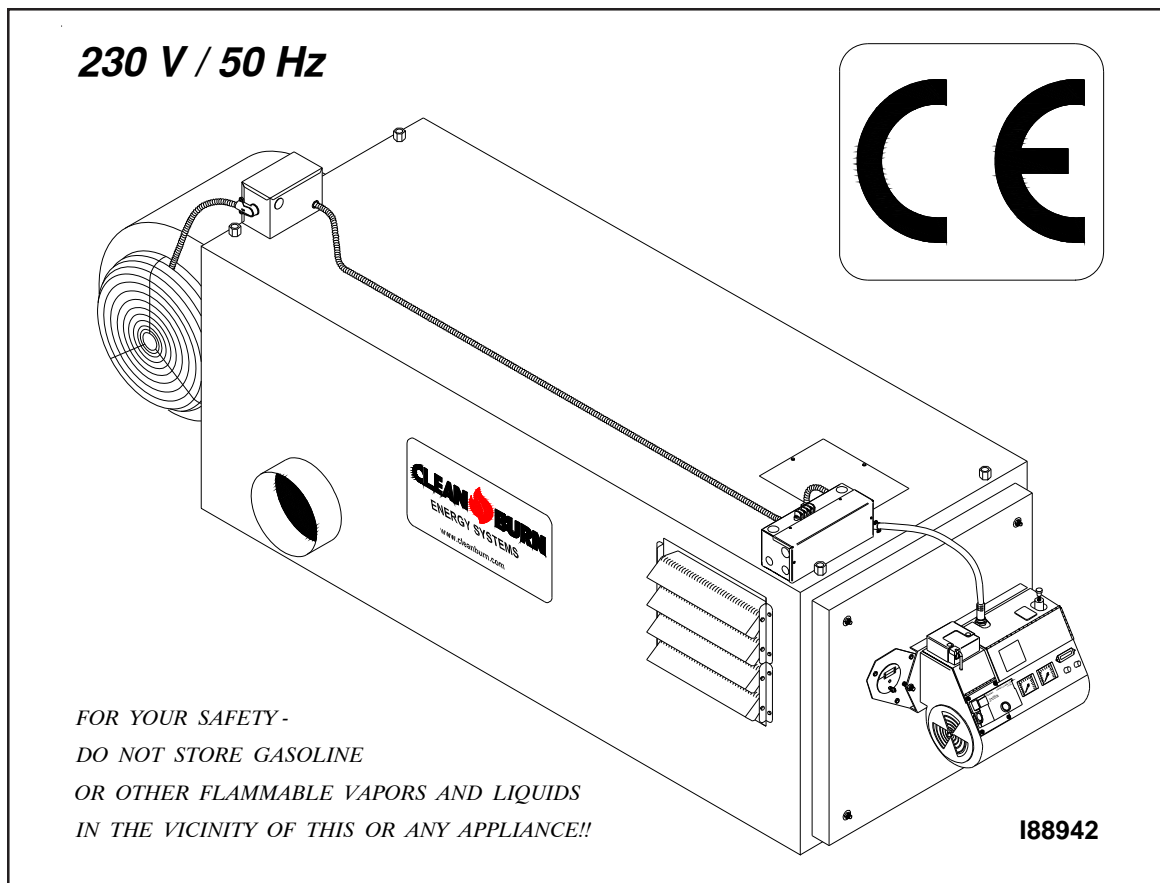

OPERATOR'S MANUAL

**CLEAN BURN MODELS: CB-1500 and CB-2500 MULTI-OIL FURNACES
with CB-500 Series Burner**



PUBLICATION DATE: 6/1/10, Rev. 4

CLEAN BURN PART # 43161



WARNING: DO NOT assemble, install, operate, or maintain this equipment without first reading and understanding the information provided in this manual. Installation and service must be accomplished by qualified personnel. Failure to follow all safety precautions and procedures as stated in this manual may result in property damage, serious personal injury or death.

CLEAN BURN, INC. • 34 Zimmerman Road • Leola, PA 17540 • U.S.A.

The Clean Burn logo is a trademark of Clean Burn, Inc. All other brand or product names mentioned are the registered trademarks or trademarks of their respective owners.

Copyright © 2009 Clean Burn, Inc. All rights reserved. No part of this publication may be reproduced, or distributed without the prior written permission of Clean Burn, Inc. 34 Zimmerman Road, Leola, PA 17540. Subject to change without notice.

CLEAN BURN ENERGY SYSTEMS **DECLARATION OF CONFORMITY**

Manufacturer: Clean Burn Inc.
34 Zimmerman Rd.
Leola, PA
USA

European Representative: Please call 1-800-331-0183 for
authorized European distributors

Equipment: CB-1500 CE # 90191
CB-2500 CE # 90158

EMC Competent Body: TÜV Rheinland Product Safety GmbH
Am Grauenstein,
D-51105 Köln

I hereby declare that the above named machinery complies with Essential Health and Safety Requirements of the Industrial Machinery Directive (IMD - 98/37/EEC) as amended, with the Low Voltage Directive (LVD – 73/23/EEC) as amended, and with the Electromagnetic Compatibility Directive (EMC – 89/336/EEC) as amended.

Safety Standard:

EN 230: 1990 Monobloc Oil Burners – Safety, Control, and Regulation Devices and Safety Times.

EN 292-1:1991 Safety of machinery - Basic concepts, general principles for design - Part 1 : Basic terminology, methodology.

EN 292-2:1991+A1 Safety of machinery - Basic concepts, general principles for design - Part 2 : Technical principles and specifications

EN 60204-1:2000 Safety of machinery. Electrical equipment of machines. General requirements.

EMC Standards:

EN 55014-1: 2000 Electromagnetic Compatibility – Requirements for Household Appliances, Electric Tools, and Similar Apparatus. Part 1: Emission.

EN 55014-2: 2000 Electromagnetic Compatibility – Requirements for Household Appliances, Electric Tools, and Similar Apparatus. Part 2: Immunity.

EN 50165: 1997 Electrical Equipment of Non-Electric Appliances for Household and Similar Purposes. Safety Requirements.

Note: Above equipment is subject to an EMC Technical Construction File and Competent Body Certificate Number AV 72031804 0001.

11 February, 2009

Ryan D. Gamber
Engineering Manager

TABLE OF CONTENTS

SECTION 1: INTRODUCTION	1-1
Guide to this Manual	1-1
For Your Safety... ..	1-2
Guidelines for Furnace Usage	1-4
Guidelines for Used Oil Tanks	1-5
Safety Labels	1-6
SECTION 2: UNPACKING	2-1
Removing the Shipping Crate	2-1
Unpacking and Inspecting All Components.....	2-1
Furnace Component List	2-1
Unpacking Items Packed Inside the Furnace	2-2
SECTION 3: FURNACE ASSEMBLY	3-1
Understanding Assembly	3-1
Required Tools and Materials	3-1
Overview of Furnace Assembly	3-2
Installing the Blower Assembly	3-3
Wiring the Blower Motor	3-4
Determining the Hot Air Discharge Configuration	3-5
Installing the Hot Air Discharge Components	3-6
Installing the Energy Retention Disc	3-9
Installing the Energy Retention Disc in the Combustion Chamber	3-9
Closing the Furnace Door	3-9
Installing the Burner	3-9
Checking the Burner Nozzle and Electrodes	3-9
Mounting the Burner on the Hinge Bracket	3-11
Installing the Connector Block, Oil Line Tubing, and Air Line Tubing	3-12
Installing the Connector Block on the Furnace Door	3-12
Installing the Oil Line Tubing	3-12
Installing the Air Line Tubing	3-13
Locking the Burner into Firing Position	3-14
SECTION 4: FURNACE INSTALLATION	4-1
Understanding Installation	4-1
Important Safety Guidelines for Safe Installation	4-1
Selecting a Location	4-5
Guidelines for Selecting a Location	4-5
Mounting the Furnace	4-6
Ceiling Mounting	4-6
Raised Platform Mounting	4-7
Floor Mounting	4-7

TABLE OF CONTENTS

SECTION 4: FURNACE INSTALLATION (continued)

Oil Tank Installation Specifications	4-8
Installing the Tank Vent and Emergency Vent	4-9
Installing the Metering Pump	4-10
Preparing for Installation	4-10
Standard Mounting: Vertical Positioning	4-10
Alternate Mounting: Horizontal Positioning	4-12
Wiring the Furnace and Pump	4-13
Wiring to the Furnace	4-13
Wiring to the Metering Pump	4-13
Installing the Suction Oil Line Components	4-14
Installing the Pressure Relief Oil Line Back to the Tank	4-17
Installing the Pressure Oil Line Components	4-18
Installing the Compressed Air Line	4-18
Installing the Stack	4-19
Stack Design and Specifications	4-19
Installing the Interior Stack	4-22
Installing the Barometric Damper	4-22
Installing the Stack Penetration	4-23
Installing the Exterior Stack	4-23
Installing the Stack Cap	4-23
Installing the Optional Draft Inducer	4-23
Installing the Wall Thermostat	4-25
Inspecting the Furnace Installation	4-25

SECTION 5: METERING PUMP PRIMING 5-1

Understanding Metering Pump Priming	5-1
Required Tools and Materials	5-1
Priming the Metering Pump	5-2
Vacuum Testing the Oil Pump	5-4

SECTION 6: STARTING AND ADJUSTING THE BURNER 6-1

Understanding Burner Startup and Adjustment	6-1
Preparing the Burner for Startup	6-1
Starting the Burner	6-3
Checking the Operation of the Blower Motor	6-4

SECTION 7: RESETTING THE FURNACE AND BURNER 7-1

Understanding Furnace/Burner Shutdowns	7-1
The Oil Primary Control	7-1
Resetting the Oil Primary Control	7-1
The Blower/Fan Switch	7-2
The Hi-Temp Limit Switches	7-2
Understanding the L-200 Hi-Temp Limit Switch	7-2
Understanding the L-290 Auxiliary Hi-Temp Limit Switch	7-2

TABLE OF CONTENTS

SECTION 8: ADJUSTING THE DRAFT OVER FIRE	8-1
Checking for Correct Draft Over Fire	8-1
Adjusting the Barometric Damper	8-2
Solving Draft Overfire Problems	8-2
Understanding the Effect of Exhaust Fans on Draft	8-3
Checking Draft Overfire to Determine Severity of Backdraft	8-3
Installing a Make-up Air Louver	8-5
SECTION 9: MAINTENANCE	9-1
Understanding Maintenance	9-1
Periodic Burner Inspection	9-2
Cleaning the Canister Filter	9-3
Servicing the Metering Pump	9-4
Cleaning Ash from the Furnace	9-5
Cleaning the Check Valve/Screen	9-7
Cleaning the Tank	9-8
Annual Burner Tune-up	9-8
End of Season Maintenance	9-8
SECTION 10: TROUBLESHOOTING.....	10-1
Troubleshooting Flow Chart	10-2
Troubleshooting Tables.....	10-3
APPENDIX A	
Detailed Furnace Specifications	A-1
Furnace Technical Specifications	A-1
Burner Technical Specifications.....	A-2
Furnace Dimensions	A-3
Burner Components	A-4
Removing the Nozzle for Cleaning	A-9
Furnace Components	A-10
CB-1500 Furnace Components	A-10
CB-2500 Furnace Components	A-12
Blower Components	A-14
CB-1500 Blower Components	A-14
CB-2500 Blower Components	A-16
APPENDIX B	
Wiring Diagrams	B-1
Furnace Wiring Diagram	B-1
Burner Wiring Diagram	B-2
Ladder Schematic	B-3
Metering Pump Wiring Schematics	B-4

TABLE OF CONTENTS

APPENDIX C

Additional Installation and Maintenance Requirements	C-1
Installing a Cover over the Oil/Air Regulators	C-1
Installing a Fire Valve	C-2

APPENDIX D

Furnace Service Record	D-1
------------------------------	-----

SECTION 1: INTRODUCTION

Guide to this Manual

This manual contains all the information necessary to safely install and operate the Clean Burn CE-certified, 230 V / 50 Hz Furnace Models CB-1500 and CB-2500. Consult the Table of Contents for a detailed list of topics covered. You'll find this manual's step-by-step procedures easy to follow and understand. Should questions arise, please contact your Clean Burn dealer before starting any of the procedures in this manual.

As you follow the directions in this manual, you'll discover that assembling and operating your new furnace involves five basic activities as outlined here:

- **UNPACKING** (Section 2)
- **ASSEMBLY** (Section 3)
- **INSTALLATION** (Section 4)
- **OPERATION**
 - **Metering Pump Priming** (Section 5)
 - **Starting and Adjusting the Burner** (Section 6)
 - **Resetting the Furnace and Burner** (Section 7)
 - **Adjusting the Draft** (Section 8)
- **MAINTENANCE** (Section 9)

The manual also contains important and detailed technical reference materials which are located at the back of the manual in the Appendixes.

Please read all sections carefully--including the important safety information found in this section--before beginning any installation/operation procedures; doing so ensures your safety and the optimal performance of your Clean Burn furnace.

WARNING!



STOP

**YOUR SAFETY IS AT STAKE!
DO NOT INSTALL, OPERATE OR
MAINTAIN THIS EQUIPMENT
WITHOUT FIRST READING
AND UNDERSTANDING THE
OPERATOR'S MANUAL!**

For Your Safety...

For your safety, Clean Burn documentation contains the following types of safety statements (listed here in order of increasing intensity):

- **NOTE:** A clarification of previous information or additional pertinent information.
- **ATTENTION:** A safety statement indicating that potential equipment damage may occur if instructions are not followed.



CAUTION: A safety statement that reminds of safety practices or directs attention to unsafe practices which could result in personal injury if proper precautions are not taken.



WARNING: A *strong* safety statement indicating that a hazard exists which can result in injury or death if proper precautions are not taken.



DANGER! *The utmost levels of safety must be observed;* an extreme hazard exists which would result in high probability of death or irreparable serious personal injury if proper precautions are not taken.

In addition to observing the specific precautions listed throughout the manual, **the following general precautions apply and *must be heeded to ensure proper, safe furnace operation.***



DANGER! DO NOT create a fire or explosion hazard by storing or using gasoline or other flammable or explosive liquids or vapors near your furnace.



DANGER! DO NOT operate your furnace if excess oil, oil vapor or fumes have accumulated in or near your furnace. As with any oil burning furnace, improper installation, operation or maintenance may result in a fire or explosion hazard.



WARNING: DO NOT add inappropriate or hazardous materials to your used oil, such as:

- Anti-freeze
- Carburetor cleaner
- Paint thinner
- Parts washer solvents
- Gasoline
- Oil additives
- Any other inappropriate/hazardous material



WARNING: Burning chlorinated materials (chlorinated solvents and oils) is *illegal*, will *severely damage* your heat exchanger, and adversely affect the proper, safe operation of your furnace. Instruct your personnel to *never* add hazardous materials to your used oil.

For Your Safety... (continued)



WARNING: Never alter or modify your furnace without prior written consent of Clean Burn, Inc. Unauthorized modifications or alteration can adversely affect the proper, safe operation of your furnace.



WARNING: The burner which is shipped with your Clean Burn furnace is to be used *only* with your furnace according to the instructions provided in this manual. **DO NOT** use the burner for any other purpose!



WARNING: Electrical installation of the furnace is to be performed only by qualified personnel (i.e. licensed electrician/engineer). Improper electrical installation can adversely affect the proper, safe operation of the furnace and may cause serious personal injury/death.



WARNING: Install the furnace in an area away from the main shop traffic. (Clean Burn recommends ceiling mounting for this purpose.) ***It is essential for personal safety that only manufacturer-trained, qualified personnel have access to operate and maintain the furnace.***



WARNING: To prevent damage to the furnace and to ensure personal safety, lifting, mounting, and hanging of the furnace must be performed in accordance with safe handling procedures.



WARNING: **DO NOT** operate your furnace when the ambient temperature is above 35° C (95° F).



WARNING: ***The Best Operator is a Careful Operator!*** By using common sense, observing general safety rules, and adhering to the precautions specific to the equipment, you, the operator, can promote safe equipment operation. ***Failure to use common sense, observe general safety rules, and adhere to the precautions specific to the equipment may result in equipment damage, fire, explosion, personal injury and/or death.***



WARNING: The installation, operation, and maintenance of this equipment must be accomplished by qualified personnel and in compliance with the specifications in the Clean Burn Operator's Manual and with all national, state, and local codes or authorities having jurisdiction over environmental control, building inspection and fuel, fire and electrical safety.



WARNING: This equipment is for commercial and/or industrial use only; it is **NOT** for residential use.



WARNING: Call your Clean Burn dealer for service. **DO NOT** allow untrained, unauthorized personnel to service your furnace. Make sure that your furnace receives periodic maintenance to ensure optimal performance

Failure to comply with these standards and requirements may result in equipment damage, fire, explosion, personal injury and/or death.

For Your Safety... (continued)

Guidelines for Furnace Usage

- This furnace is listed for commercial and/or industrial use only; it is *not* listed for residential use.
- This furnace is designed to burn the following fuels:
 - Used crankcase oil up to 50 SAE
 - Used transmission fluid
 - Used hydraulic oils
 - #2 fuel oil
 - #4 fuel oil
 - #5 fuel oil

NOTE: Used oils may contain other substances, including gasoline, that may hinder performance.

- Make sure you comply with all environmental regulations concerning the use of your furnace. These regulations require that:
 - Your used oil is generated on-site. You may also accept used oil from "do-it-yourself" oil changers.
 - Hazardous wastes, such as chlorinated solvents, are NOT to be mixed with your used oil.
 - The flue gases are vented to the outdoors with an appropriate stack.
 - Your used oil is recycled as fuel for "heat recovery". DO NOT operate your furnace in warm weather just to burn oil.

Contact your local Clean Burn dealer for current environmental regulations.

- If your furnace ever requires service, call your Clean Burn dealer. DO NOT allow untrained, unauthorized personnel to service your furnace. Make sure that your furnace receives annual preventative maintenance to ensure optimal performance.



For Your Safety... (continued)

Guidelines for Used Oil Tanks

For the safe storage of used oil and the safety of persons in the vicinity of the used oil supply tank, ensure that your tank installation adheres to the following safety guidelines:

- **The tank installation must meet all national and local codes.** Consult your local municipal authorities for more information as necessary.
- **Review and adhere to the safety guidelines for used oil supply tanks as stated in the WARNING shown.**
- Ensure that the tank for your furnace installation complies with all code and safety requirements as stated here. If the tank does not comply, **DO NOT** use it.
- If you do not have a copy of the tank safety label pictured at right, please contact your Clean Burn dealer for the label, which is to be affixed directly on your used oil supply tank.

WARNING

Fire and explosion hazards.
 To prevent serious injury or death:

ONLY place these listed substances in this used-oil supply tank:

- Used crankcase oil
- Used automatic transmission fluid
- Used hydraulic oil
- #2 fuel oil

Do NOT place flammable or corrosive substances such as gasoline, chlorinated oils, solvents, paint thinners, or any other unsafe substances in this used-oil supply tank.

Do NOT weld or allow open flame within 35 feet of this used-oil supply tank.

Tank installation MUST comply with NFPA 30 and 31 Fire Codes, including the following requirements:

- Tank must be listed to UL 80 or UL 142.
- Tank must be vented to outside.
- Emergency vent or explosion relief must be installed on tank.
- Inside fill allowed only with funnel including 1/4 turn-to-close ball valve, which must be closed after filling.
- All other openings must be plugged.
- All oil lines must be constructed of copper, steel, or brass components. Do NOT use rubber or plastic tubing or piping, or any other inappropriate material.



Follow all instructions for tank installation in Operator's Manual.

42366

For Your Safety... (continued)

Safety Labels

Following are the locations and descriptions of all labels on your CB-1500 or CB-2500 furnace. The following illustrations show the location of ALL labels on your furnace. Please note that some labels denote model number, model description, etc. while others contain important safety messages.

Each **Safety Label** contains an important safety message starting with a key word as discussed earlier in this section (e.g. ATTENTION, CAUTION, WARNING, DANGER). For your safety and the safe operation of your furnace, review all labels and heed all safety messages as printed on the labels.

If any labels on your Clean Burn furnace ever become worn, lost or painted over, please call your Clean Burn dealer for free replacements.

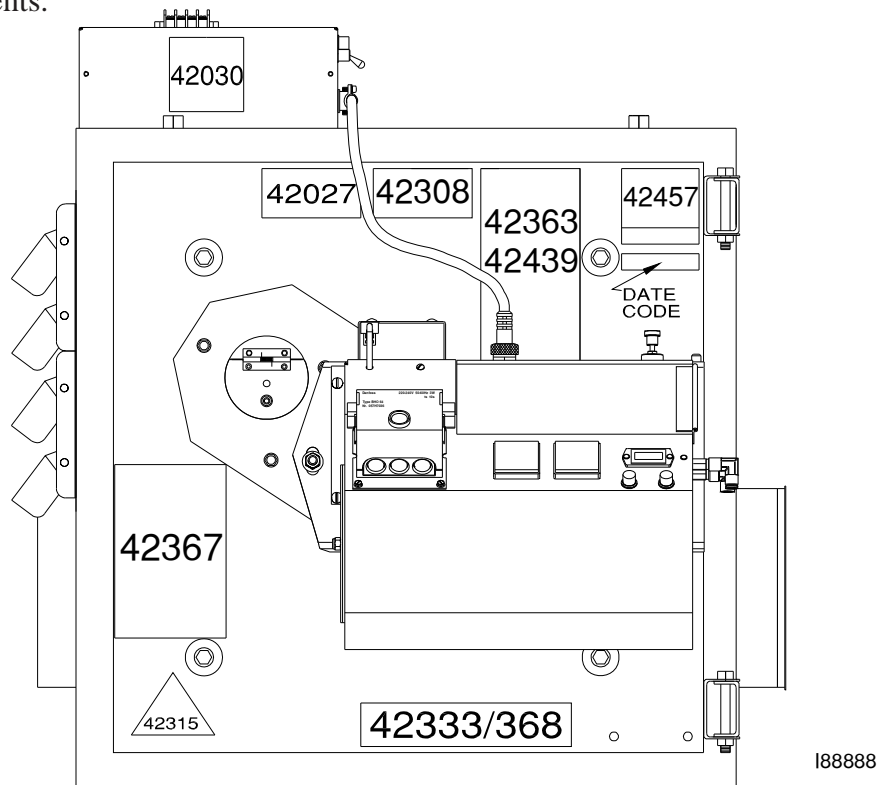

Label Part







Description

42030	Furnace Electrical Shock Hazard Warning Label (<i>several locations</i>)
42027	Furnace Burn Hazard/Hazardous Voltage Warning Label
42308	Header Label
42363	CE Data Label - CB-2500
42439	CE Data Label - CB-1500
42341	Cleaning Combustion Chamber/Target Caution Label
42457	Made in USA / Pat Pending Combination Label
42333	Model CB-2500 Label
42368	Model CB-1500 Label
42367	Furnace Safety Warning Label (Multiple Messages - Fire/Shock/Burn Hazards)
42315	Burn Hazard - Hot Surface Warning Label
42068	Furnace Blower/Fan Entanglement Hazard Warning Label (<i>near blower</i>)

For Your Safety... (continued)

CB-1500/CB-2500 Furnace Cabinet Safety Labels

 WARNING
<p>Hazardous voltage.</p> <p>To prevent serious injury, shut OFF main power to unit before removing cover.</p> <p>Line voltage is present on most subbase terminals when power is ON. If the furnace is not wired correctly, fire, shock or damage could result.</p> <ul style="list-style-type: none"> • ONLY a qualified electrician should wire this furnace. • ONLY use copper conductors. <p style="text-align: right; font-size: small;">42030</p>

 WARNING
<p>Fire, explosion and burn hazards:</p>
<div style="display: flex; align-items: center;">  <div> <p>Maintain clearances from combustibles as listed on unit. ONLY burn used crankcase oil, automatic transmission fluid, hydraulic oil, or #2 fuel oil. NEVER burn any other substances in this unit.</p> </div> </div>
<div style="display: flex; justify-content: space-around; align-items: center;">    </div> <p>Hot gases and ash may be released when inspection port is opened.</p> <ul style="list-style-type: none"> • Wear safety goggles and hand protection when opening inspection port. • Keep face away and open port slowly.
<div style="display: flex; align-items: center;">  <div> <p>To avoid possible injury, death, or equipment damage, read and understand operator's manuals and all safety precautions before installing, operating, or servicing this equipment.</p> </div> </div> <p style="text-align: right; font-size: small;">42367</p>

 	 WARNING
<p>Burn Hazard. Hazardous Voltage.</p> <p>Burner may fire at any time. Disconnect burner power cord before swinging open burner or clean-out door.</p> <p style="text-align: right; font-size: small;">42027</p>	

 	 WARNING
<p>Entanglement and cutting hazard.</p> <p>Blower can start at any time. Turn power OFF before servicing. Do NOT operate without guard in place.</p> <p style="text-align: right; font-size: small;">42068</p>	

For Your Safety... (continued)

CB-1500/CB-2500 Furnace Cabinet Safety Labels

CLEAN BURN, INC.

LEOLA, PENNSYLVANIA (USA)

CE

MODEL NO. CB 2500

BTU/HR (KW) 250,000 73

INPUT RATING W/NO. 2 FUEL OIL

LISTED FUELS	INPUT		ATOM AIR PRESS		OIL PRESS	
	-GPH-	-LTR/H-	-PSIG-	-BAR-	-PSIG-	-BAR-
NO 2 OIL	1.7	6.4	18.0	1.2	3.5	0.24

USED OILS INCLUDE:

	1.7	6.4	18.0	1.2	3.5	0.24
CRANKCASE OIL	1.7	6.4	16.0	1.1	4.0	0.28
HYDRAULIC OIL	1.7	6.4	17.0	1.2	4.0	0.28
ATF	1.7	6.4	17.0	1.2	4.0	0.28

MAX. DISCHARGE AIR TEMPERATURE 200°F (94°C) FLUE DRAFT IN. W.C. -.04 (-1 mm)

CLEARANCE TO COMBUSTIBLE SURFACES: INCHES / (cm)

	TOP	FRONT	REAR FROM BLOWER	BOTTOM	CHIMNEY	HEATED AIR DISCHARGE SIDE	SIDE
	12 (30)	60 (152)	2 (5)	24 (61)	18 (46)	60 (152)	18 (46)

	POWER	VOLTS	AMPS	HZ
FAN MOTOR HP.	1	230	5.0	50
OIL PUMP MOTOR HP.	1/17	230	0.4	50
BURNER MOTOR HP.	1/10	230	0.45	50
BURNER HEATER WATTS	450	230	1.7	50
DRAFT IND. (OPT) HP	1/50	230	0.5	50
AIR COMPRESS. (OPT) HP.	1/3	230	1.8	50
TOTAL CIRCUIT AMPS (UNIT HEATER)			10	
MAXIMUM FUSE SIZE			15	

THE MAINTENANCE INTERVAL FOR CLEANING ASH FROM THE FURNACE IS APPROXIMATELY 700 HOURS. THE ASH LEFT FROM THE BURNING OF USED OIL MAY CONTAIN METALLIC COMPOUNDS OR FOREIGN MATERIALS. THE ASH MUST BE DISPOSED OF PROPERLY.

BURNER REQUIRES A MINIMUM AIR SOURCE OF:
2 S.C.F.M. (57 L/MIN.) AT 25 P.S.I. (1.72 BAR).
THIS APPLIANCE IS NOT TO BE USED WITH AIR FILTERS AND SHALL INCORPORATE NO PROVISIONS FOR MOUNTING AIR FILTERS.

42363

CLEAN BURN, INC.

LEOLA, PENNSYLVANIA (USA)

CE

MODEL NO. CB 1500

BTU/HR (KW) 150,000 44

INPUT RATING W/NO. 2 FUEL OIL

LISTED FUELS	INPUT		ATOM AIR PRESS		OIL PRESS	
	-GPH-	-LTR/H-	-PSIG-	-BAR-	-PSIG-	-BAR-
NO 2 OIL	1.1	3.9	14.0	1.0	1.3	0.1

USED OILS INCLUDE:

	1.1	4.0	14.0	1.0	2.0	0.1
CRANKCASE OIL	1.1	4.0	14.0	1.0	2.0	0.1
HYDRAULIC OIL	1.1	4.0	14.0	1.0	2.0	0.1
ATF	1.1	4.0	16.0	1.1	2.0	0.1

MAX. DISCHARGE AIR TEMPERATURE 200°F (94°C) FLUE DRAFT IN. W.C. -.04 (-1 mm)

CLEARANCE TO COMBUSTIBLE SURFACES: INCHES / (cm)

	TOP	FRONT	REAR FROM BLOWER	BOTTOM W/LOUVERS	CHIMNEY	HEATED AIR DISCHARGE SIDE	SIDE
	12 (30)	60 (152)	2 (5)	24 (61)	18 (46)	60 (152)	18 (46)

SIDE-WHEN AIR DISCHARGE IS ON BOTTOM WITH LOUVERS-60 IN. (152)

	POWER	VOLTS	AMPS	HZ
BLOWER MOTOR HP.	3/4	230	4.0	50
OIL PUMP MOTOR HP.	1/17	230	0.4	50
BURNER MOTOR HP.	1/10	230	0.45	50
BURNER HEATER WATTS	450	230	1.7	50
DRAFT IND. (OPT) HP	1/50	230	0.5	50
AIR COMPRESS. (OPT) HP.	1/3	230	1.8	50
TOTAL CIRCUIT AMPS (UNIT HEATER)			9	
MAXIMUM FUSE SIZE			15	

THE MAINTENANCE INTERVAL FOR CLEANING ASH FROM THE FURNACE IS APPROXIMATELY 700 HOURS. THE ASH LEFT FROM THE BURNING OF USED OIL MAY CONTAIN METALLIC COMPOUNDS OR FOREIGN MATERIALS. THE ASH MUST BE DISPOSED OF PROPERLY.

BURNER REQUIRES A MINIMUM AIR SOURCE OF:
2 S.C.F.M. (57 L/MIN.) AT 25 P.S.I. (1.72 BAR).
THIS APPLIANCE IS NOT TO BE USED WITH AIR FILTERS AND SHALL INCORPORATE NO PROVISIONS FOR MOUNTING AIR FILTERS.

42439

CLEAN BURN, INC.

LEOLA, PA

USED-OIL BURNING APPLIANCE

NO.

CE

MULTI-OIL HEATING SYSTEM

INSTALL AND USE ONLY IN ACCORDANCE WITH THE MFR'S INSTALLATION AND OPERATING INSTRUCTIONS. FOR COMMERCIAL OR INDUSTRIAL USE ONLY.

AUTHORITIES HAVING JURISDICTION SHOULD BE CONSULTED PRIOR TO INSTALLATION.

42308

For Your Safety... (continued)

CB-1500/CB-2500 Burner Labels

<u>Label Part #</u>	<u>Description</u>
42004	Burner Safety Warning Label (High Voltage/Moving Parts Hazards)
42235	Burner Safety Warning Label (Fire/Explosion Hazard - Burner Installation and Service)
42339	Burner Model/Serial Number Label
42229	Logo/Burner Description Label
42482	Reset Warning Label
42309	CE Mark Label
42023	Burner Power Label
42457	Made in USA / Pat Pending Combination Label (<i>on side</i>)

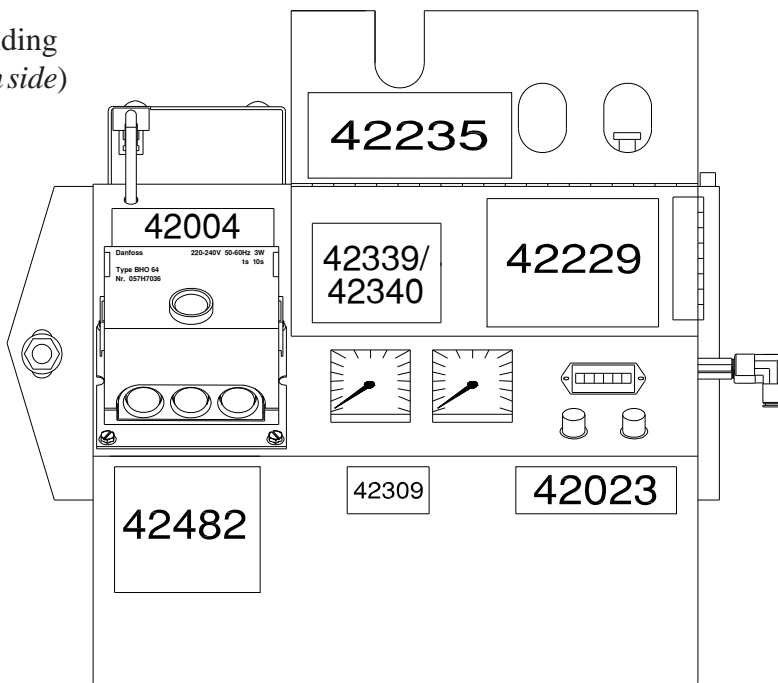

188889

CB-1500/CB-2500 Burner Safety Labels

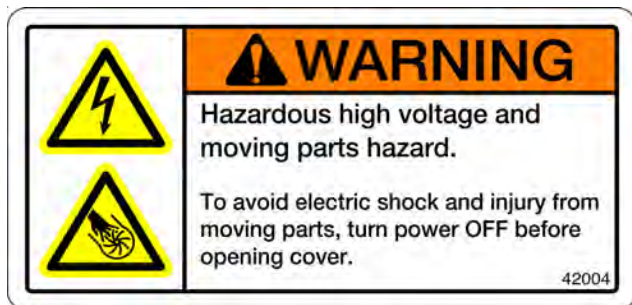

SECTION 2: UNPACKING

Before assembling your furnace, you must accomplish the following activities described in this section:

- Removing the Shipping Crate
- Unpacking and Inspecting All Components

Removing the Shipping Crate

NOTE: Remove the shipping crate prior to assembly and installation of the furnace. **DO NOT** use the crate as a platform for furnace installation!

1. Carefully remove the top boards of the shipping crate. Then remove the front, back, and side panels of the shipping crate.
2. Carefully lift the furnace off the shipping pallet with a fork lift.

ATTENTION: **DO NOT** attempt to slide the furnace cabinet out of the shipping crate--you may damage the furnace cabinet.

Unpacking and Inspecting All Components

Following is an itemized list of all components you should have received in your Clean Burn furnace shipment. Open all shipping containers and inspect all components according to the list. Immediately notify the freight company and your Clean Burn dealer in case of shipping damage or shortage(s). Keep all components together so you will have them as needed for furnace assembly and installation.

Furnace Component List

ONE SKID containing:

- Furnace cabinet
- Items packed *inside* furnace cabinet (combustion chamber):

NOTE: *Please refer to the procedure on the following page to remove these items.*

- Target
- Hot air discharge assembly components plus hardware
- Furnace accessories:
 - Canister filter
 - Check valve and screen
 - Barometric damper
 - Burner oil line/air line components
 - Assorted bolts/fittings for assembly of furnace components
 - Vacuum gauge
 - Wall thermostat
 - Connector block
 - Operator's Manual

ITEMS PACKED IN INDIVIDUAL BOXES:

- Burner
- Blower
- Metering Pump

NOTE: You may have received additional boxes or skids if you ordered optional accessories.

Unpacking Items Packed Inside the Furnace

To unpack the items packed inside the furnace cabinet (in the combustion chamber), you will need to open the combustion chamber door.

1. Remove the four nuts and washers which hold the combustion chamber door closed. Set the nuts and washers aside in a safe place for later re-installation after the target has been installed (Section 3).
2. Carefully swing the combustion chamber door open. Remove and inspect the components packed inside.
3. Leave the door unfastened (open) for assembly/installation procedures to be accomplished in the next section.

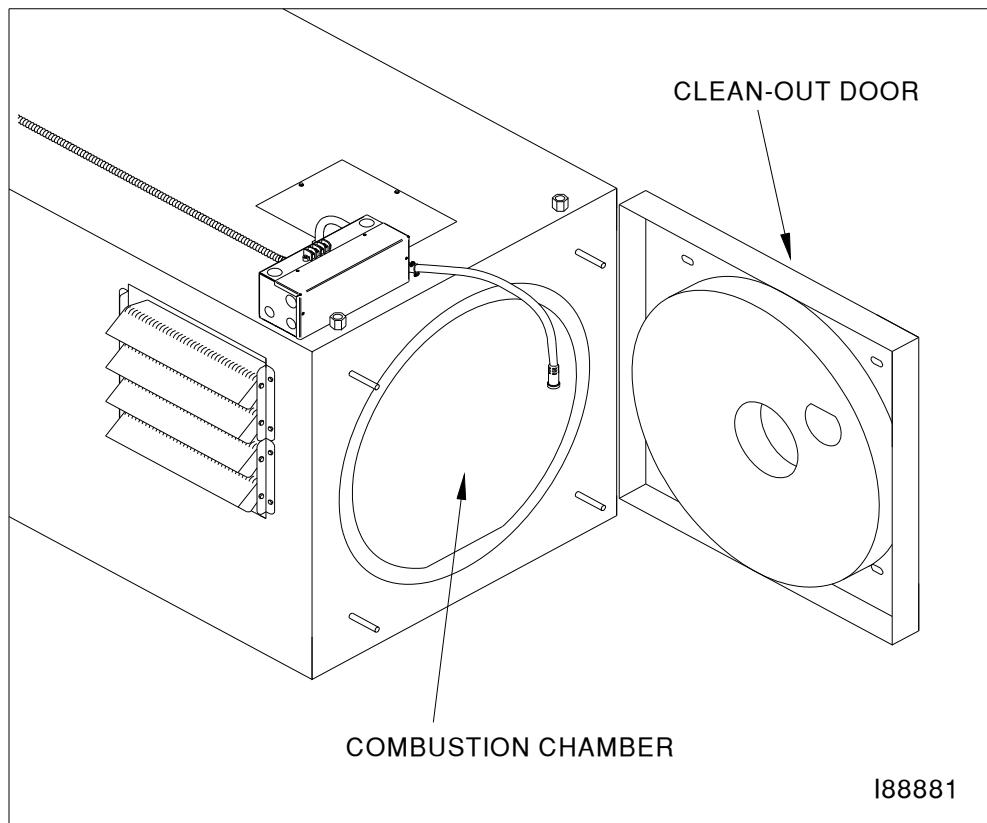

Figure 2A - Accessing the Combustion Chamber

SECTION 3: FURNACE ASSEMBLY

Understanding Assembly

Assembling your Clean Burn Furnace includes the following steps:

- (1) Installing the Blower Assembly
- (2) Installing the Hot Air Discharge Components
- (3) Installing the Energy Retention Disc
- (4) Installing the Burner
- (5) Installing the Connector Block, Oil Line Tubing, and Air Line Tubing

Clean Burn recommends that you review all assembly procedures before proceeding, paying careful attention to safety information statements.

Figure 3A on the following page provides a general overview of the furnace components and their proper assembly.

Required Tools and Materials

The following tools are required for furnace assembly and should be gathered before starting any procedures:

- 3/8" open-end wrench
- 9/16" open-end wrench
- Medium flat-blade screwdriver
- Medium adjustable wrench
- 1/4" nut driver attachment for drill
- Variable speed drill

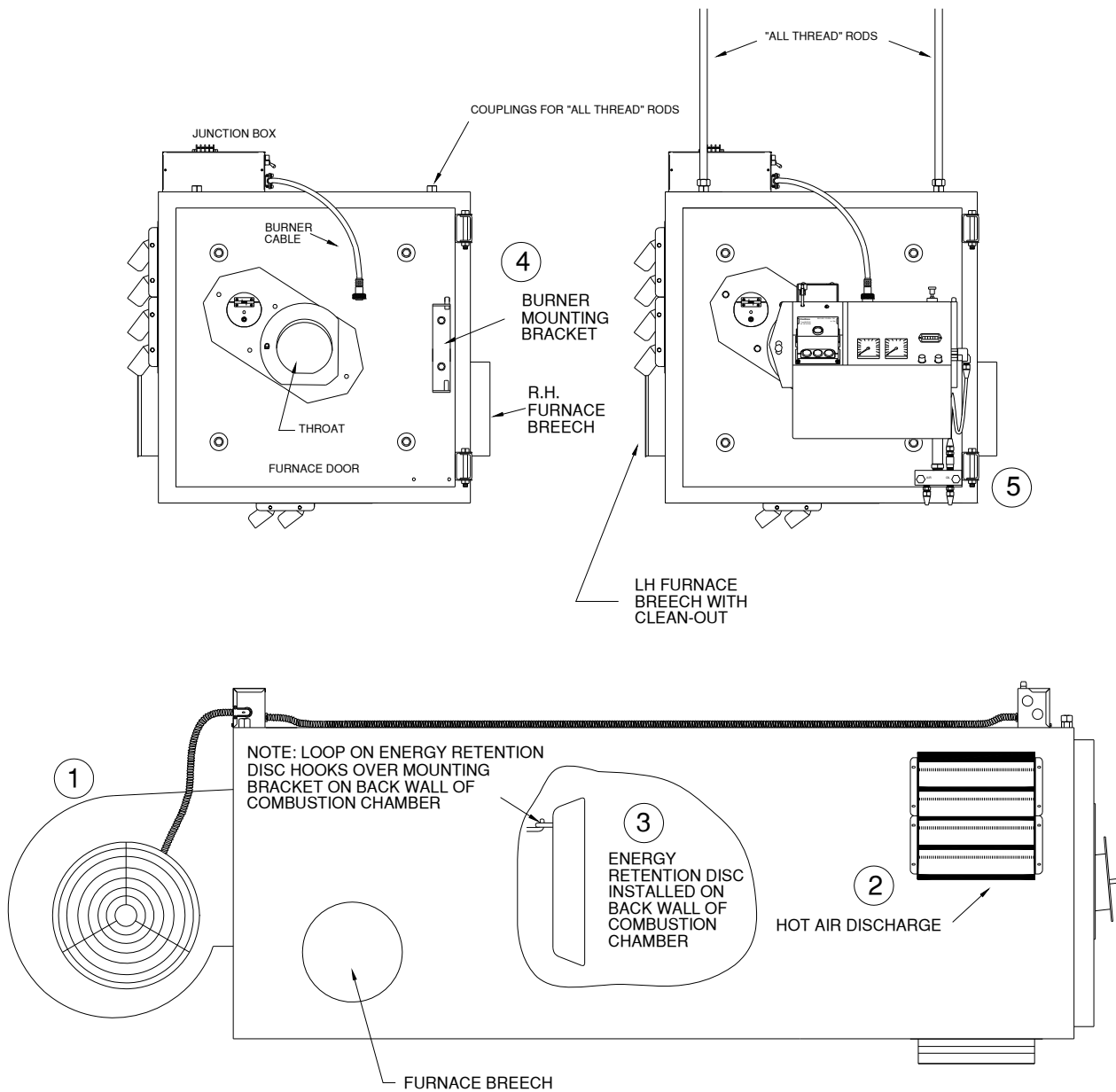

NOTICE THE VARIOUS MOUNTING CHOICES FOR THE LOUVERS
IT IS OK TO OPEN OR RESTRICT THE LOUVERS AS NEEDED, AND THEN
TO TURN THOSE CONFIGURATIONS IN ANY OF FOUR DIRECTIONS

188943

Complete assembly of the CB-1500/CB-2500 furnace according to the following list of activities as illustrated above:

- (1) Installing the Blower Assembly
- (2) Installing the Hot Air Discharge Components
- (3) Installing the Energy Retention Disc
- (4) Installing the Burner
- (5) Installing the Connector Block, Oil Line Tubing, and Air Line Tubing

NOTE: Corresponding procedures provided in order in this section.

Figure 3A - Overview of 2500 Furnace Assembly (CB-1500 is similar)

Installing the Blower Assembly

1. Refer to Figures 3B and 3C.
2. Remove the blower stabilizer brackets as shown in Figure 3B. (These braces, which are installed at the factory, are designed to keep the blower in proper position during shipping. Note that these braces are provided on CB-2500 blower assemblies ONLY; CB-1500 blower assemblies do not require these special shipping braces.)
3. Position the blower over the opening in the back of the furnace cabinet by sliding the blower into the mounting angle brackets. Note that the mounting brackets may be loosened for adjustment, as needed. The blower should be centered over the opening.
4. Fasten the blower to the brackets with self-tapping screws (provided). Drive the screws into the blower housing through the holes in the mounting angle brackets. There are four holes along each side and across the top of the bracket to fasten the blower to the furnace cabinet.
5. Install the blower safety guards as shown.



WARNING: To avoid serious personal injury, be sure to install both pieces of the blower guard around the blower prior to operating the furnace. NEVER operate the furnace without **all** safety shields/guards in place!

ATTENTION: The air flow is changed when the guards are not in place which may result in damage to the blower motor.

NOTE: For proper air flow through the furnace cabinet the blower must be positioned so that the bulge on the blower faces down as illustrated in Figures 3A, 3B, and 3C.

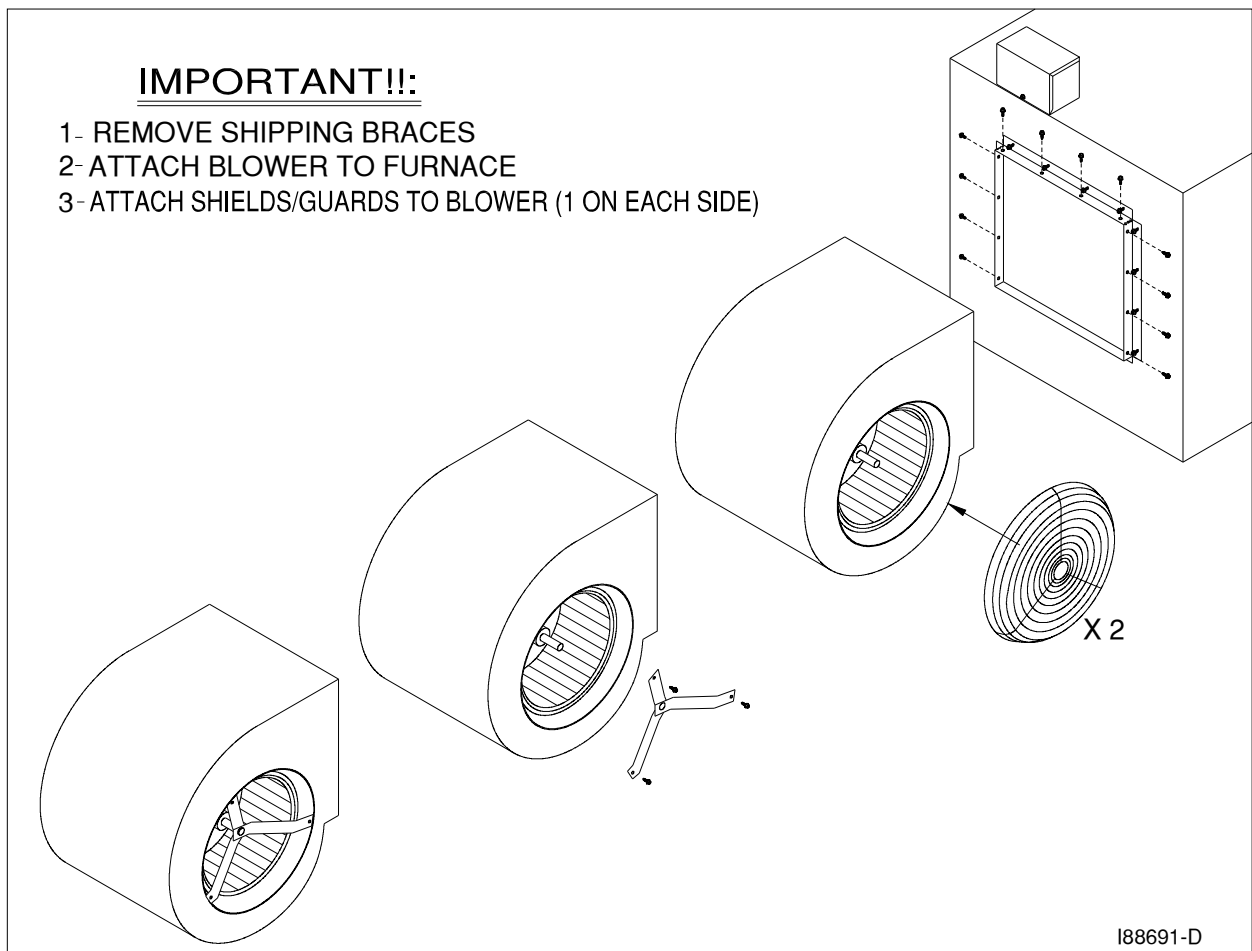

Figure 3B - Installing the Blower Assembly

Installing the Blower Assembly (continued)

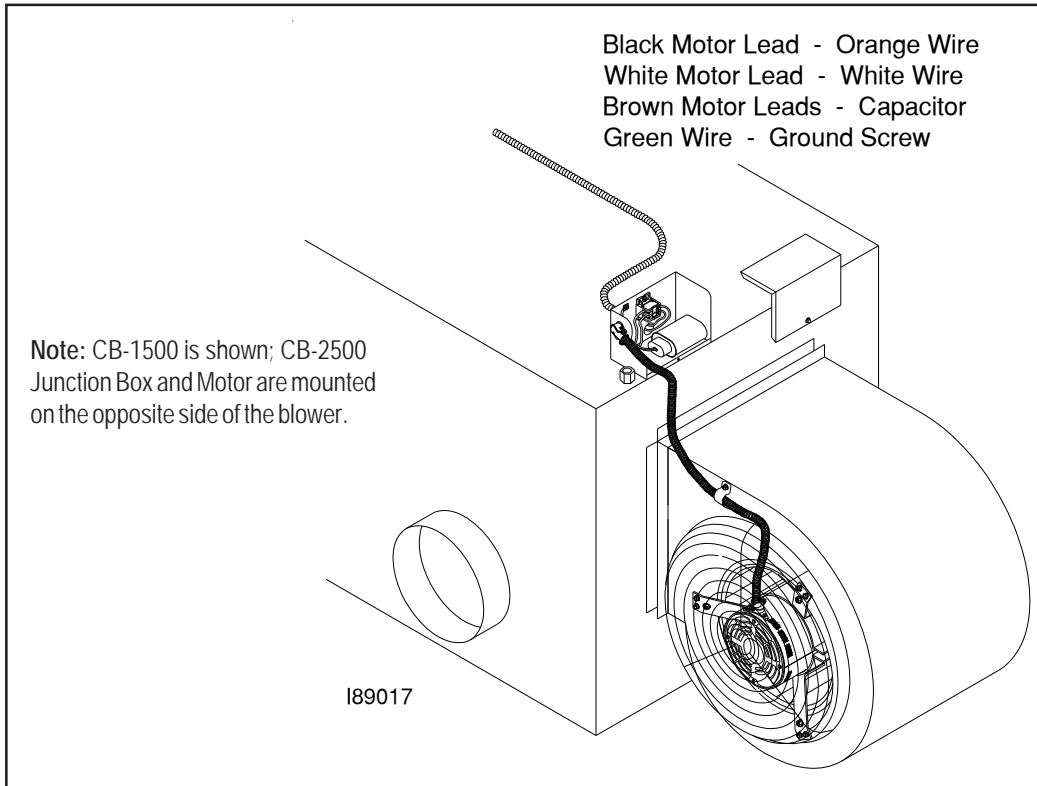

Figure 3C - Blower Installed on Furnace Cabinet

Wiring the Blower Motor



WARNING: Make sure the main power to the furnace is turned OFF before wiring the blower motor.

NOTE: For reference, wiring schematics are provided in Appendix B at the back of the manual.

1. After the blower has been secured to the back of the furnace cabinet, install the electrical conduit with the blower motor leads into the 4" x 6" rear junction box on the top of the furnace cabinet as shown in Figure 3C.
 - Connect the power lead coming from the blower assembly to the 4" x 6" electrical box mounted on the rear of the furnace cabinet.
 - Connect the black (power) motor lead wire to the connector block terminal with the orange (power) wire from the front electrical box.
 - Connect the white (neutral) motor lead wire to the connector block terminal with the white (neutral) wire from the front electrical box.
 - Connect the two brown leads to the capacitor and mount it inside the electrical box with the strap provided.

Determining the Hot Air Discharge Configuration

Before proceeding with the assembly of your furnace, it is important to determine the configuration of the air discharge for your furnace. There are three configurations to consider for the CB-2500 and two possible configurations for the CB-1500:

- (1) **Unit Heater**
CB-1500 and CB-2500
- Furnace with blower assembly for FREE AIR applications.**
 Follow the instructions (provided in this section) to install the blower assembly and air discharge components. *Be sure to adhere to the proper specified clearances for Unit Heater Configurations as stated in Section 4 of this manual.*
- CB-1500* Equipped with two (2) louver sections and four (4) blank cover panels
CB-2500 Equipped with three (3) louver sections and three (3) blank cover panels
- (2) **Central Furnace (A)**
CB-1500 and CB-2500
- Furnace with blower assembly for DUCTING applications with 0.06 kPa (0.25 "WC) or less static pressure.***
 Follow the instructions to install the blower assembly, and refer to the following chart for the proper air discharge and ducting specifications. *Be sure to adhere to the proper specified clearances for Central Furnace Configurations as stated in Section 4 of this manual.*
- CB-1500* Do not install louvers. Ductwork should be installed directly over the desired air discharge opening on the side of the furnace cabinet (305 mm x 305 mm).
- CB-2500* Determine which side of the furnace cabinet will have the ductwork attached. Replace the left or right side inner shield and shrouding to accommodate the ductwork. Do not install louvers. Ductwork should be installed directly over the desired air discharge opening on the side of the furnace cabinet (395 mm x 395 mm).
- | | |
|---------------------------|-----------------------------|
| #29184 Inner Shield Right | #29186 Right Side Shrouding |
| #29185 Inner Shield Left | #29187 Left Side Shrouding |
- Install an additional blank cover panel to close off the remaining air discharge opening.
 #29115 Cover Discharge Closure Panel
- (3) **Central Furnace (B)**
CB-2500 ONLY
- Furnace with blower assembly for DUCTING applications from 0.06 kPa (0.25 "WC) to 0.10 kPa (0.40 "WC) static pressure.***
 Follow the instructions to install the blower assembly, and refer to the following chart for the proper air discharge and ducting specifications. *Be sure to adhere to the proper specified clearances for Central Furnace Configurations as stated in Section 4 of this manual.*
- CB-2500* Same as above - Central Furnace (A)

Determining the Hot Air Discharge Configuration (continued)

Air Flow - Cubic Meters per Minute (CMM) or Cubic Feet per Minute (CFM) and Static Pressure (SP) Specifications

CB-1500

Air Discharge Louvers Mounted on Furnace	Air Discharge Louvers Removed With Ductwork Installed on Furnace
Free Air*	0.06 kPa* (0.25 INCHES WC)
40 CMM (1400 CFM)	34 CMM (1200 CFM)

CB-2500

Air Discharge Louvers Mounted on Furnace	Air Discharge Louvers Removed With Ductwork Installed on Furnace	Air Discharge Louvers Removed With Ductwork Installed on Furnace
Free Air*	0.06 kPa* (0.25 INCHES WC)	0.10 kPa* (0.40 INCHES WC)
71 CMM (2500 CFM)	68 CMM (2400 CFM)	64 CMM (2250 CFM)

***ATTENTION:** A qualified electrician must check the blower motor amperage during operation of the furnace to ensure that motor amperage does not exceed 85% of the maximum amperage on the motor label. DO NOT operate the blower motor above 85% of maximum amperage or motor damage may occur.

IMPORTANT NOTE: *It is essential that qualified HVAC personnel properly design the ductwork for your furnace and determine the static pressure for your ducting application. Note that existing ductwork at your installation site may not be appropriate or meet the specifications for this furnace installation. For static pressure readings as shown in the chart above, the ductwork should be installed directly over the opening in the SIDE of the furnace cabinet (i.e. where the louver panels would be installed for free air applications.) For Central Furnace applications, ductwork may NOT be installed over the bottom opening.*

Installing the Hot Air Discharge Components

It is very important to properly install the hot air discharge components (louvers and blank cover panels) to direct the flow of air from the furnace. As you will note from Figures 3D and 3E, the air discharge panels are to be installed on the side(s) and/or bottom of the furnace. *The air flow may be directed down, front, or back depending on how the louvers and cover panels are installed.*

IMPORTANT NOTE FOR CENTRAL FURNACE APPLICATIONS:

- **For ducting applications with static pressure, DO NOT** install the louvers. The ductwork should be installed directly over the desired air discharge opening on the side of the furnace cabinet.
CB-1500 opening in side shrouding for ductwork - 305 mm x 305 mm (12" x 12")
NO changes need to be made for the shrouding outlet size
CB-2500 opening in side shrouding for ductwork - 395 mm x 395 mm (15 1/2" x 15 1/2")
Install new inner shield and outside shrouding with larger opening sizes
- **Ductwork must be installed over side opening(s) ONLY.** Ductwork may NOT be installed over the bottom air discharge opening.

Installing the Hot Air Discharge Components (continued)

1. Refer to Figures 3D and 3E. Determine the desired air flow discharge pattern. Note that the CB-1500 is supplied with (2) louver sections and (4) blank cover panels. The CB-2500 is supplied with (3) louver sections and (3) blank cover panels. Air discharge openings are: (1) on each side of the furnace, and (1) on the bottom of the furnace.
2. Install the louver panels in the desired location(s) with the self-tapping screws provided. Holes are pre-drilled in the furnace cabinet to accommodate installation of the panels.
3. Adjust the louvers for the desired air flow direction.
ATTENTION: DO NOT restrict the flow of the hot air from the furnace by closing the louvers, or the furnace will not operate properly.
4. Install the blank covers over the remaining air discharge opening(s) on the furnace cabinet.

Air Flow Discharge Installation Guidelines:

- When determining the placement of the air discharge louvers, you also need to consider the **required clearances from combustibles** as stated in Section 4 of this manual.
- Note that the CB-1500 is supplied with (2) louver sections which may be installed **together** on one side or the bottom OR the louvers may be **split** for partial air discharge on each side and/or bottom. If a side contains only one louver section it should be mounted on the upper portion.

NOTE: Bottom louver installation applies to Unit Heater furnaces ONLY. Ductwork for Central Furnace applications may NOT be installed over the bottom opening.

CB-2500 IS SHOWN
(CB-1500 IS SIMILAR)

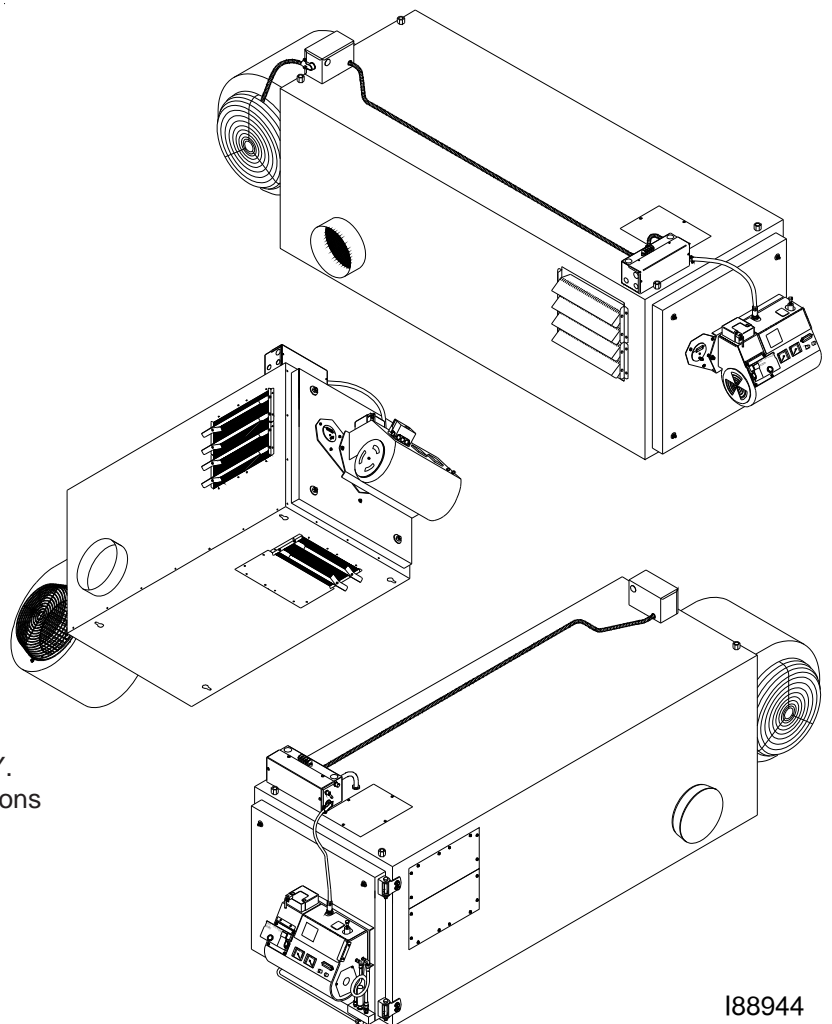

188944

Figure 3D - Hot Air Discharge Components (Louvers/Blank Covers) Installed on Furnace

Installing the Hot Air Discharge Components (continued)

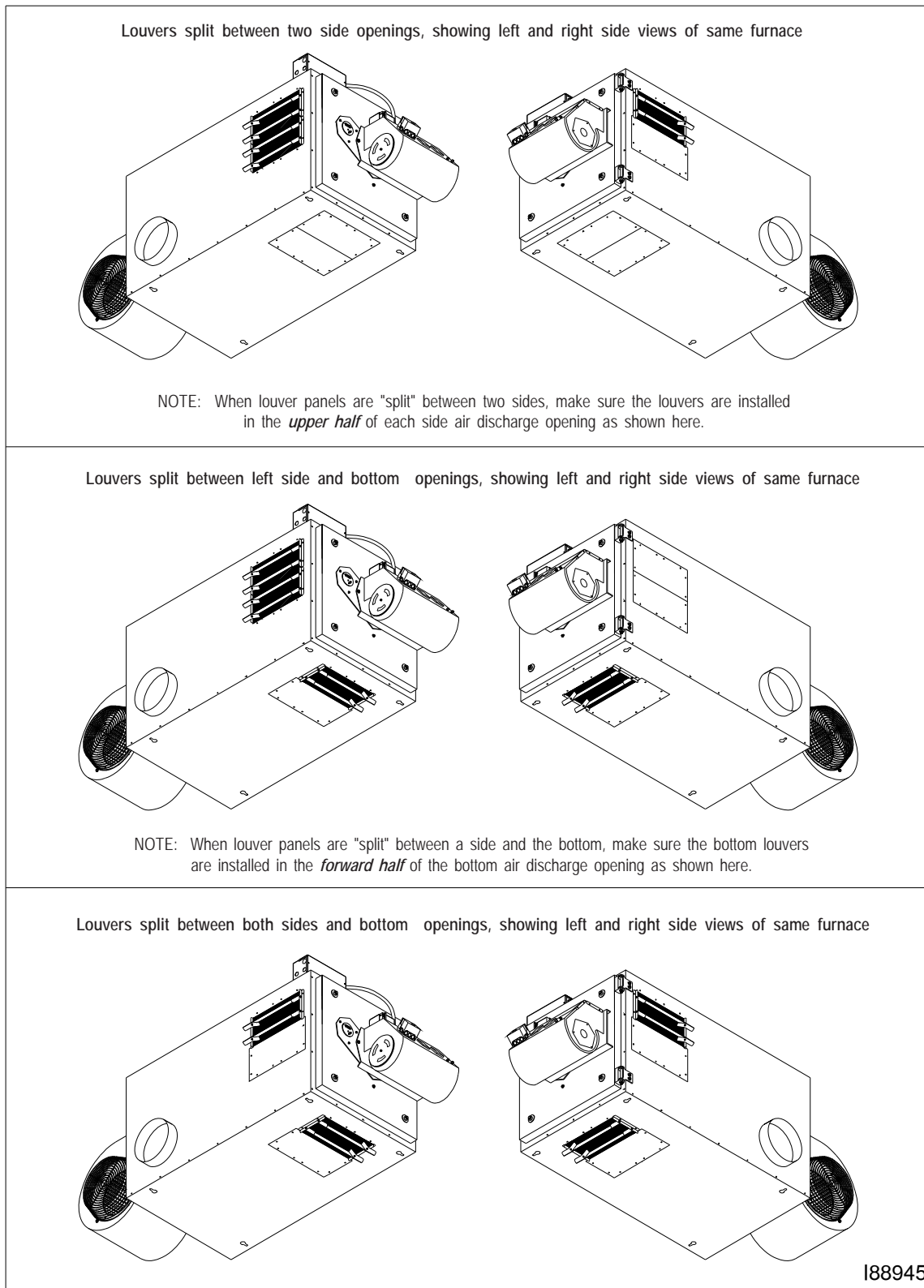

Figure 3E - Sample Split Louver Installations for Partial Air Discharge on Sides and/or Bottom. CB-2500 is shown. CB-1500 is similar with two (2) louver sets and four (4) blank cover panels.

Installing the Energy Retention Disc

Installing the Energy Retention Disc at the Back of the Combustion Chamber

ATTENTION: DO NOT fire your furnace without the Energy Retention Disc in place, or combustion chamber damage will occur. Handle the Energy Retention Disc carefully to avoid damaging it.

1. Refer to Figure 3A to review the proper positioning of the Energy Retention Disc.
2. Swing open the clean-out door on the furnace front to gain access to the combustion chamber.
3. Use a long rod to support the Energy Retention Disc as you guide it into position on the back of the combustion chamber. The loop on the back of the Energy Retention Disc fits over the hook located on the back of the combustion chamber.

Closing the Furnace Door

1. After the Energy Retention Disc has been installed, close the furnace clean-out door.
2. Tighten the four (4) lock-down nuts in a criss-cross pattern until all are snug.

Installing the Burner

Checking the Burner Nozzle and Electrodes

NOTE: The burner nozzle is factory installed. Both furnace models (CB-1500, CB-2500) use a Delavan 9-5 nozzle. The nozzle size is indicated on the nozzle as shown in Figure 3F on the following page. Refer also to **Appendix A** at the back of the manual for additional specifications/instructions on the burner nozzle.

ATTENTION: Check the electrode settings as specified in Figure 3F. The electrode settings must be correct for your burner to operate properly.

Installing the Burner (continued)

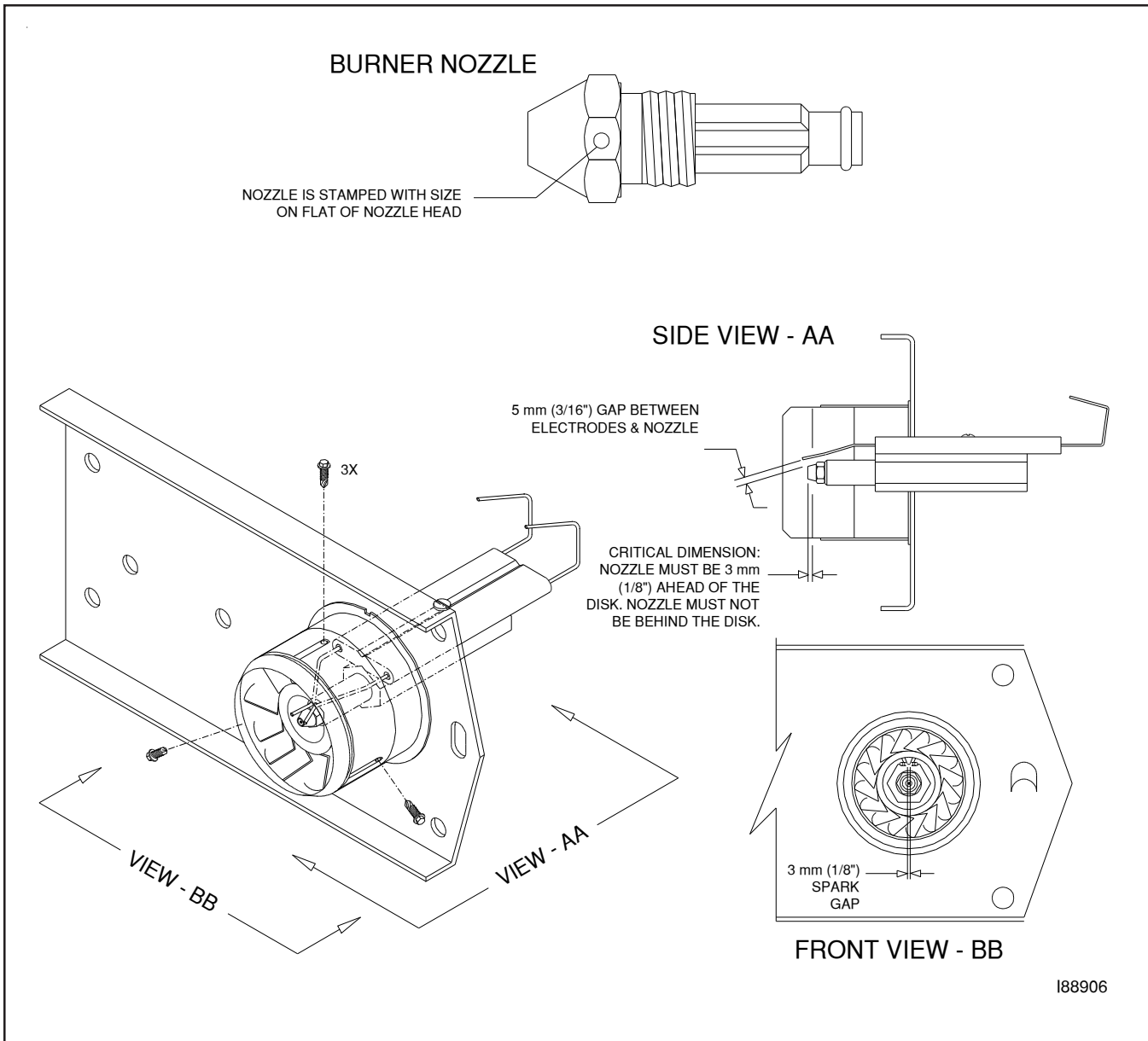

Figure 3F - Burner Nozzle and Electrode Specifications

Installing the Burner (continued)

Mounting the Burner on the Hinge Bracket

ATTENTION: Burner tube components (e.g. electrodes and retention head) are factory set. Handle the burner with extreme care so that burner components are not damaged.

1. Remove the nut from the mounting flange of the furnace cabinet, and set it aside for later use.
2. Lift the burner into position so that it is mounted on the hinge bracket on the furnace cabinet.
3. Carefully swing the burner so the retention head enters the throat of the furnace.
4. Check the clearance between the retention head and the furnace throat. *There must be at least 1/8" clearance, so the retention head is not "bumped" as you swing the burner into firing position.*

NOTE: If the retention head "bumps" the furnace throat, adjust the hinge bracket bolts as follows:

- While supporting the burner, slightly loosen the two (2) hinge bracket bolts.
- Carefully re-position the burner so it swings freely into its firing position.
- With the burner in its firing position, re-tighten the hinge bracket bolts.

Installing the Connector Block, Oil Line Tubing, and Air Line Tubing

ATTENTION: DO NOT use teflon tape on any fittings. Teflon tape residues will plug vital burner components.

Installing the Connector Block on the Furnace Door

1. Refer to Figure 3G.
2. Use the two (2) bolts to install the aluminum connector block onto the furnace cabinet.
3. Remove and discard the red caps and plugs from the fittings and ports on the connector block. **DO NOT** allow any dirt/debris to enter these components during furnace assembly.

ATTENTION: The connector block includes an accumulator. The accumulator functions like a shock absorber on the oil line to prevent pressure buildup and protect vital burner components. It is important that the connector block is installed as shown so that the accumulator is in a vertical position to prevent sediment from settling in the accumulator. *Never operate your furnace without the connector block and accumulator properly installed on the furnace, or damage may occur to vital burner components.*

Installing the Oil Line Tubing

ATTENTION: DO NOT disassemble the compression fitting from the swivel fitting. To prevent leaks, the NPT threads of the compression fitting have been sealed with hydraulic sealant during assembly of the fittings at the factory.

1. Remove and discard the red caps from the oil line tubing.
2. Loosely install the oil line tubing into the oil line fitting on the burner.
3. Use a wrench to slightly rotate the oil line fitting on the burner counterclockwise so the tubing lines up with the swivel assembly. Slightly bend the tubing as shown in Figure 3H, if required, to "line up" the oil line.
4. If necessary, use a tubing cutter to cut the tubing to the proper length.

ATTENTION: Due to adjustment of the burner hinge bracket, the oil line tubing may need to be cut to fit properly. **DO NOT** lift up on the burner when installing the oil line tubing to compensate for oil line tubing that is too long. This will place the weight of the burner on the swivel fitting and result in leaks at the swivel fitting seal.

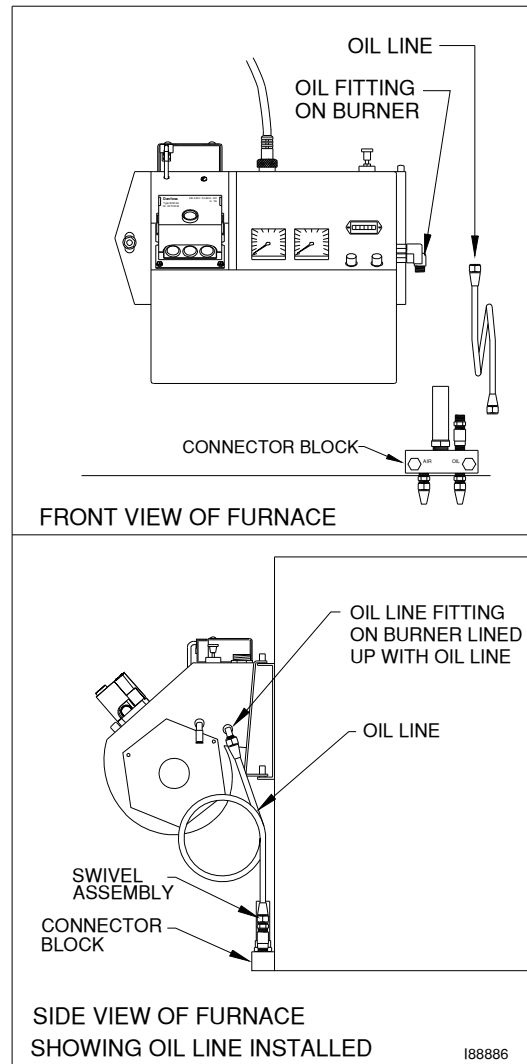

Figure 3G - Installation of Connector Block and Oil Line

Installing the Connector Block, Oil Line Tubing, and Air Line Tubing (continued)

Installing the Oil Line Tubing (continued)

5. Make sure that the curl in the oil line is positioned as shown in Figure 3G so that the burner can swing open correctly.
6. Install the oil line tubing and tighten the nuts on the compression fittings. **DO NOT** overtighten these fittings to avoid damaging the ferrules.

NOTE: You may also check the positioning of the oil line according to Figure 3H which provides a larger front view of the connector block assembly.

Installing the Air Line Tubing

1. Remove and discard the red caps from the air line tubing.
2. Refer to Figure 3H. Push the air line tubing into the swivel fitting on the connector block until the tubing bottoms out in the fitting.
3. Repeat this procedure to connect the air line tubing to the air line fitting on the side of the burner.

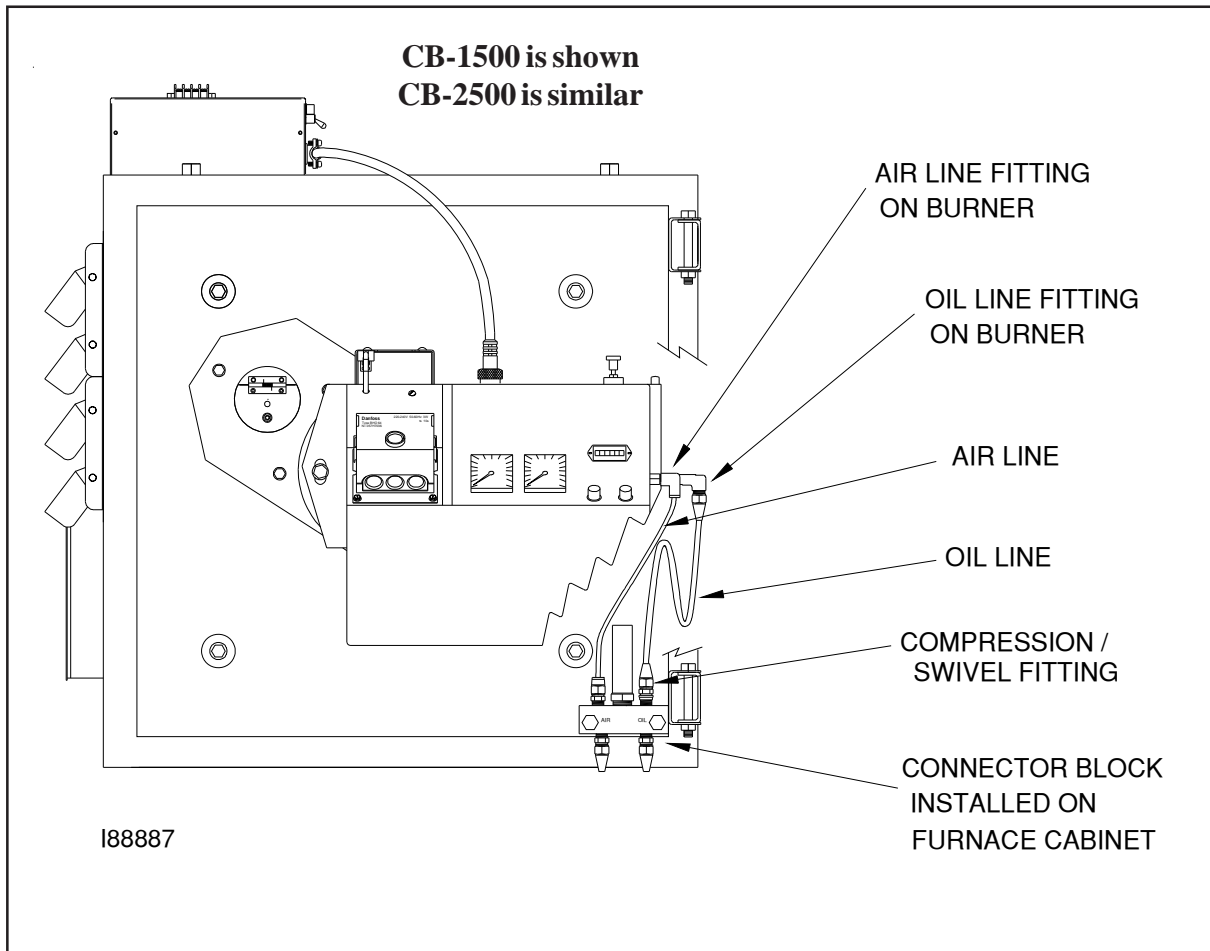

Figure 3H - Installation of Connector Block, Oil Line and Air Line (Front View)

Locking the Burner Into Firing Position

1. Swing the burner into firing position.
2. Install and tighten the lock-down nut on the mounting plate bolt to secure the burner in its firing position.
3. Plug the burner electrical cable into the receptacle on the top of the burner housing.
4. Tighten the locking ring to secure the electrical cable.

NOTE: Be sure to properly align the plug when plugging it into the receptacle. See Fig 3I.

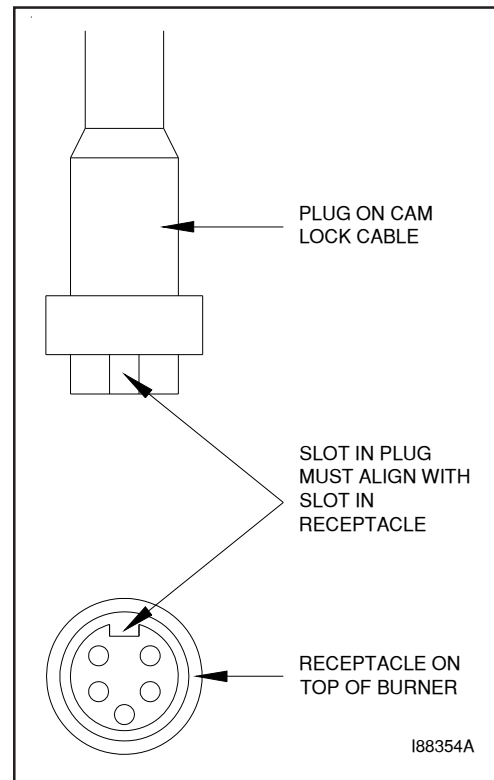

Figure 3I - Detail of Burner Electric Receptacle

NOTE: Your furnace is now assembled and ready for installation. Install the furnace as soon as possible so the burner and/or blower are not "bumped" or damaged. If you must store the furnace for a period of time before installation, make sure it is located in a safe, secure area.

SECTION 4: FURNACE INSTALLATION

Understanding Installation

Installing your Clean Burn furnace is a multi-step process which includes:

- (1) Selecting a Location
- (2) Mounting the Furnace
- (3) Oil Tank Installation Specifications (review)
- (4) Installing the Metering Pump
- (5) Wiring the Furnace and Pump
- (6) Installing the Oil Lines
- (7) Installing the Compressed Air Line
- (8) Installing the Stack
- (9) Installing the Wall Thermostat
- (10) Inspecting the Installation

Clean Burn recommends that you review all procedures before beginning installation, paying careful attention to safety information statements. **Figures 4A and 4B** provide a general overview of a typical furnace installation and should be reviewed closely before proceeding.



WARNING: Improper installation can adversely affect the proper, safe operation of your furnace. It is critical that your furnace installer reads and follows the instructions provided in this manual. Access to the furnace must be restricted; only trained, qualified personnel should be permitted to perform installation and operation procedures.



WARNING: To prevent damage to the furnace and to ensure personal safety, lifting, mounting, and hanging of the furnace must be performed in accordance with safe handling procedures.

Important Safety Guidelines for Safe Installation

General installation of the appliance shall be in accordance with the manufacturer's literature, in addition to complying with the following:

BS5410 Code of Practice for Oil Firing

1997: Installation up to 45 KW output capacity for space heating and hot water supply purposes.

1998: Installation of 44 KW and above capacity for space heating, hot water and steam supply purposes.

1978: Installation for furnaces, kilns, ovens and other industrial purposes.

The Building Regulations:

England and Wales: Approved Document J: Heat Producing Appliances (1991).

Scotland: Technical standards for compliance with the Building Standard (Scotland) Regulations 1990, Part F: Heat Producing Installations and Storage of Liquid and Gaseous Fuels.

Northern Ireland: The Building Regulations (Northern Ireland) 1990. Technical Booklet L - Heat Producing Appliances, July 1991.

Republic of Ireland: The Building Regulations of Ireland 1997, Part J: Heat Producing Appliances.

Isle of Man, Jersey and Guernsey: The Building Bylaws - BS 7671: 1992 IEE Wiring Regulations 16th Edition.

Important Safety Guidelines for Safe Installation (continued)

The Environmental Protection Act 1990, Part 1: Processes prescribed for air pollution control by local enforcing authorities PG1/1 (95).

Secretary of State's Guidance: Waste Oil Burners, less than 0.4 MW net rated thermal input. November 1995 (Appendix A of OFTEC OFSA 103).

OFTEC Guidelines: Document OFG100 for externally serviced oil fired appliances.

Important Notes to the Electrician

 **WARNING:** Electrical installation of the furnace is to be performed only by qualified personnel (i.e. licensed electrician/engineer). Improper electrical installation can adversely affect the proper, safe operation of the furnace and may cause serious personal injury/death.

 **WARNING:** Before completing any furnace wiring, refer to the wiring diagrams in Appendix B at the back of the manual. Carefully review the wiring assignments and colors, noting that the Clean Burn wire colors may not be "standard" or familiar.

 **WARNING:** High earth leakage current / earth connection is essential and must be established before connecting the main power supply.

 **WARNING:** Low voltage terminals are only protected by basic insulation--caution is required.

 **CAUTION:** Use only approved wire conduit and connectors when wiring the Clean Burn furnace. An emergency stop device (i.e. "panic button") must be installed at ground level in the mains cable to the furnace to ensure the safety of furnace operators and service personnel. The external disconnect device must employ a contact separation of 3mm in all poles; the external breaker must be an approved type.

 **CAUTION:** The main cable must be introduced into the control box using conduit connectors which provide adequate strain relief. The main cable installation must be accomplished using suitably rated and approved wiring (BASEC or HAR) or appropriate current-carrying capacity. The wires should have a minimum rating of 90 degrees C.

NOTE: According to Clause 4A of 61000-3-11 (International Electrical Standard), the user must determine, in consultation with the supply authority, that the furnace is connected only to a supply with an impedance of $3.773 \times 10^{-3} + 2.358 \times 10^{-3}$ or less.

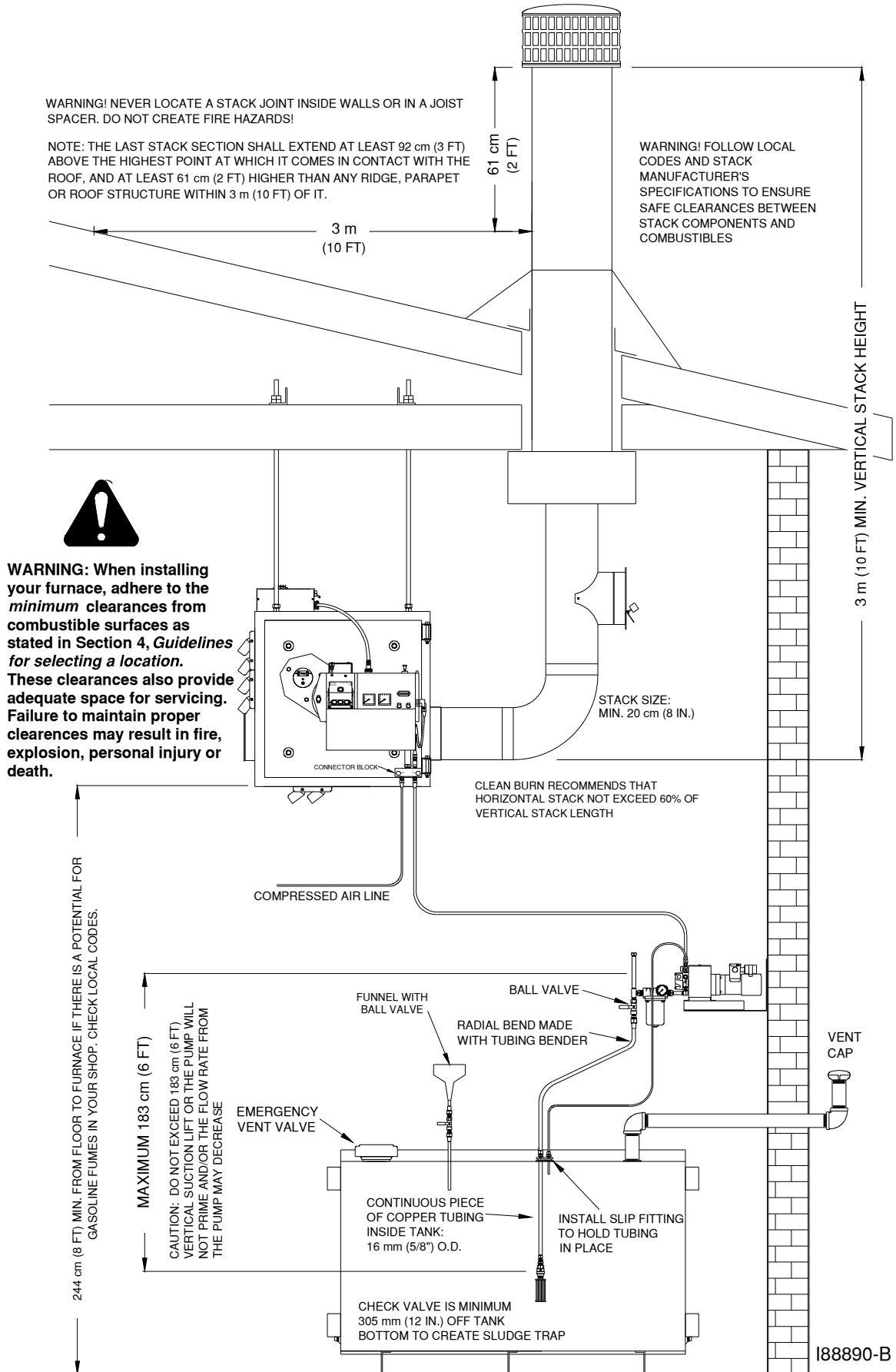

Figure 4A - Typical CB-2500 Furnace Installation (CB-1500 is similar)

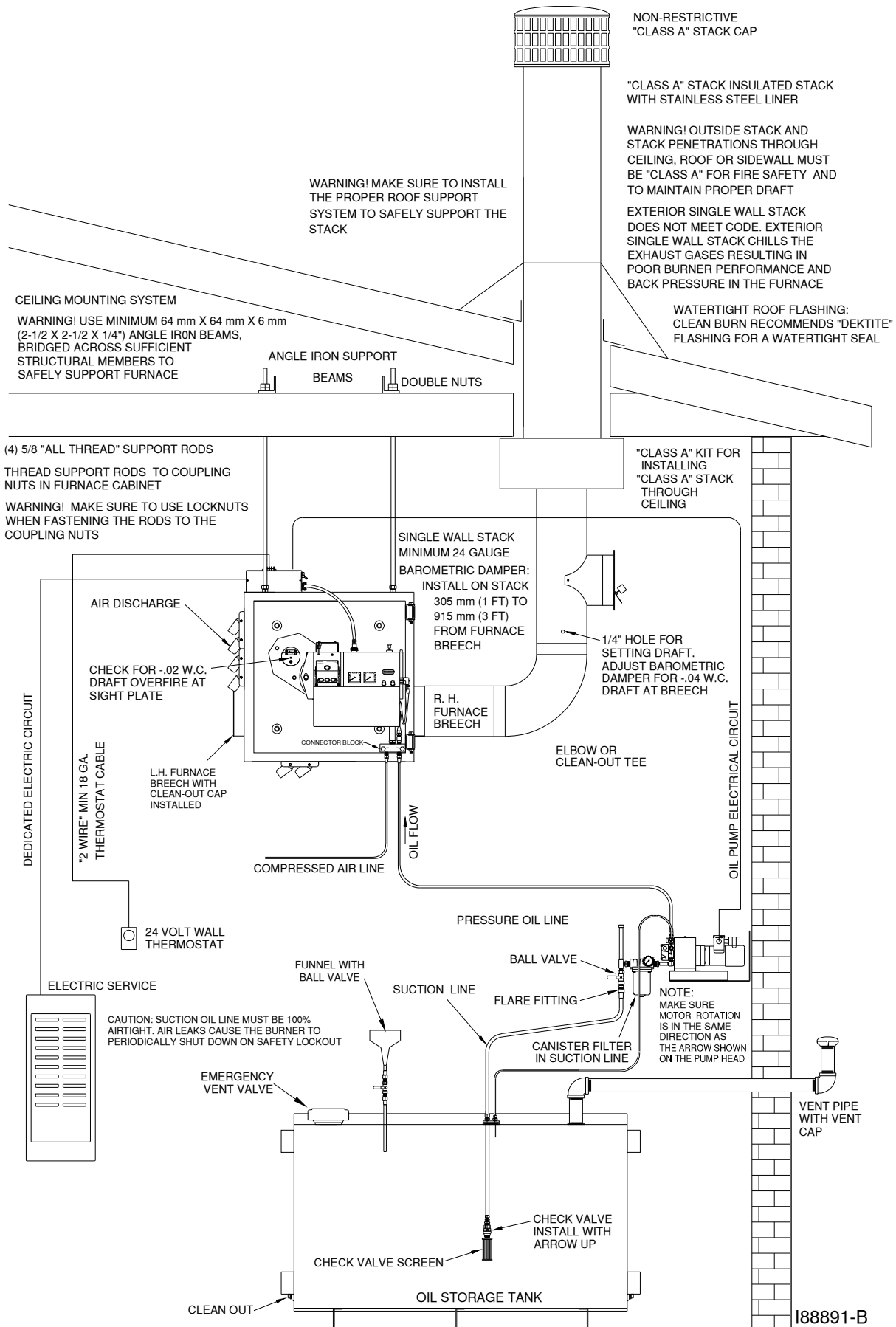

Figure 4B - Typical CB-2500 Furnace Installation - Detailed (CB-1500 is similar)

Selecting a Location

Guidelines for Selecting a Location

The location you select for your furnace must allow the following:

- Unobstructed, even heat distribution.
- Safe, easy access for servicing.
- Unobstructed passage for shop vehicles and equipment.
- Proper clearances from combustibles. *Verify according to your local safety codes.*
- Adequate combustion air per local codes.
- Proper stack installation.



WARNING: Adhere to the following *minimum* clearances from combustible surfaces and to provide adequate clearance for servicing (also refer to Figure 4C); failure to maintain proper clearances may result in fire, explosion, personal injury or death.

<p>CLEARANCES FOR UNIT HEATER INSTALLATION WITH <i>SIDE</i> AIR DISCHARGE</p> <ul style="list-style-type: none"> • TOP (of furnace) 31 cm (12") • FRONT (burner) 153 cm (60") • SIDE with Air Discharge 153 cm (60") • OTHER SIDE 46 cm (18") • CHIMNEY CONNECTOR 46 cm (18") • REAR (from blower) 5 cm (2") • BOTTOM 61 cm (24") 	<p>CLEARANCES FOR UNIT HEATER INSTALLATION WITH <i>BOTTOM</i> AIR DISCHARGE</p> <ul style="list-style-type: none"> • TOP (of furnace) 31 cm (12") • FRONT (burner) 153 cm (60") • SIDE (with or without stack) 153 cm (60") • CHIMNEY CONNECTOR 46 cm (18") • REAR (from blower) 5 cm (2") • BOTTOM with Air Discharge 97 cm (38")
<p>CLEARANCES FOR CENTRAL FURNACE INSTALLATION</p> <ul style="list-style-type: none"> • TOP (of furnace) 31 cm (12") • FRONT (burner) 153 cm (60") • SIDE without stack 46 cm (18") • CHIMNEY CONNECTOR 46 cm (18") • REAR (from blower) 5 cm (2") • BOTTOM 61 cm (24") • WARM AIR DUCTS 15 cm (6") within 92 cm (3ft) 	<p> WARNING: Your local codes may require that your furnace is mounted a minimum of 244 cm (8 ft.) off the ground if there is the possibility of gasoline fumes or other combustible or explosive fumes in your shop area.</p>

Refer to Figure 4C on the following page for an illustration of proper clearances from combustibles.

Selecting a Location (continued)

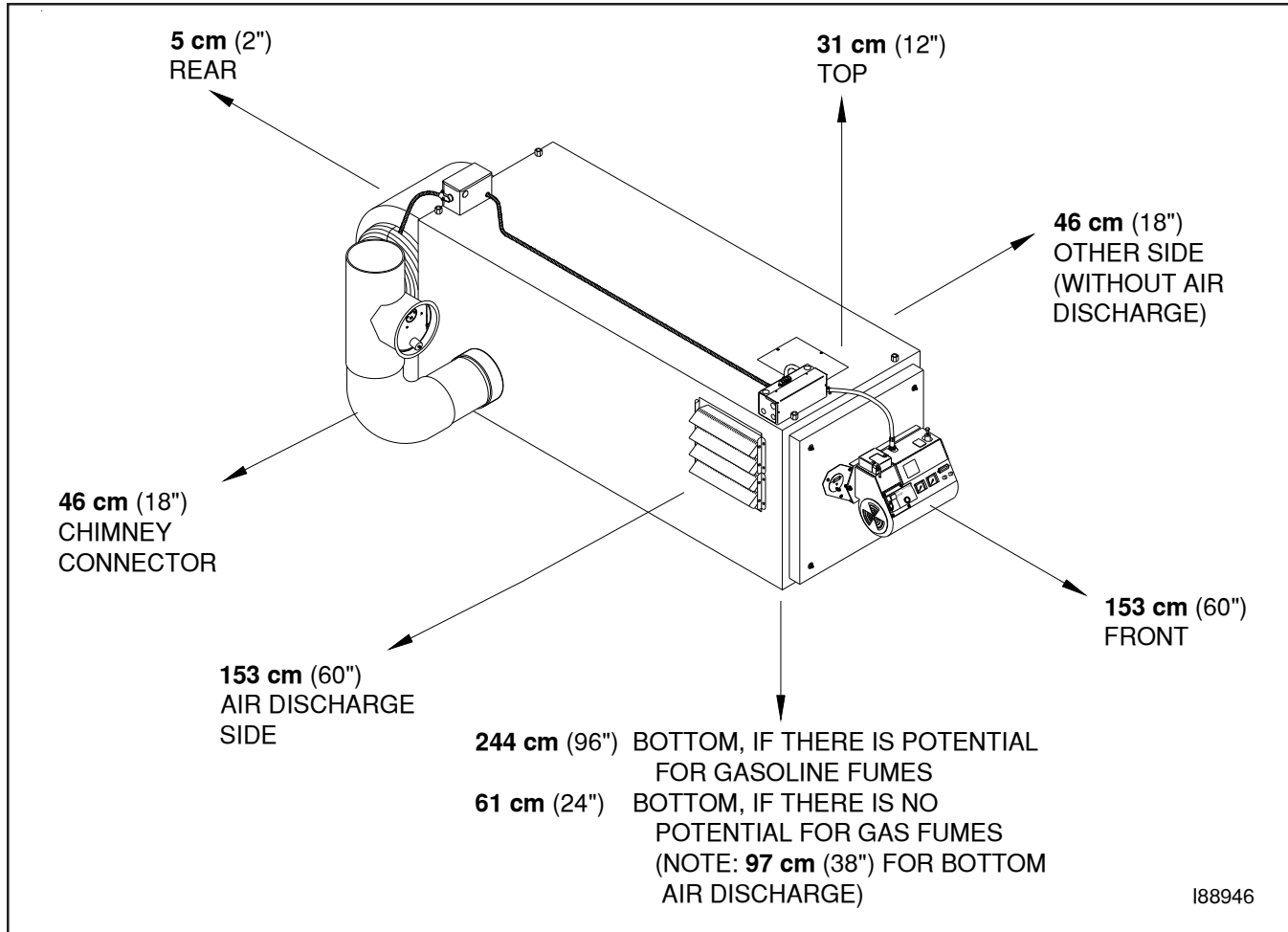

Figure 4C - Clearances from Combustibles

Mounting the Furnace

After selecting a safe and appropriate location for your furnace, construct the mounting system as required by the location and the following specifications.

Ceiling Mounting



WARNING: To prevent serious personal injury, ensure that your furnace mounting system can safely bear the suspended weight of the furnace and allow safe servicing of furnace components. Use adequately sized square tubing or angle iron bridged across sufficient structural members to safely support the furnace.

1. Refer to Figures 4A and 4B.
2. Follow the instructions as provided in the diagrams.
3. Use a spirit level to make sure the cabinet is level side to side and front to back.

Mounting the Furnace (continued)

Raised Platform Mounting

WARNING: To prevent serious personal injury, make sure the platform is designed to safely bear the weight of the furnace and allow safe servicing of furnace components. The platform must be constructed of non-combustible materials (e.g. steel) and must be securely anchored to an adjacent wall.

1. Refer to Figure 4D, and follow the instructions as provided in the diagram.

Floor Mounting

WARNING: To prevent serious personal injury, make sure the floor can safely bear the weight of the furnace.

CAUTION: If you are installing your furnace in an area with a combustible floor, you must construct a *non-combustible* floor as shown in Figure 4E.

NOTE: Make sure that blank cover panels are installed over the bottom air discharge opening to allow safe floor mounting.

1. Refer to Figure 4E and follow the instructions as provided in the diagram.

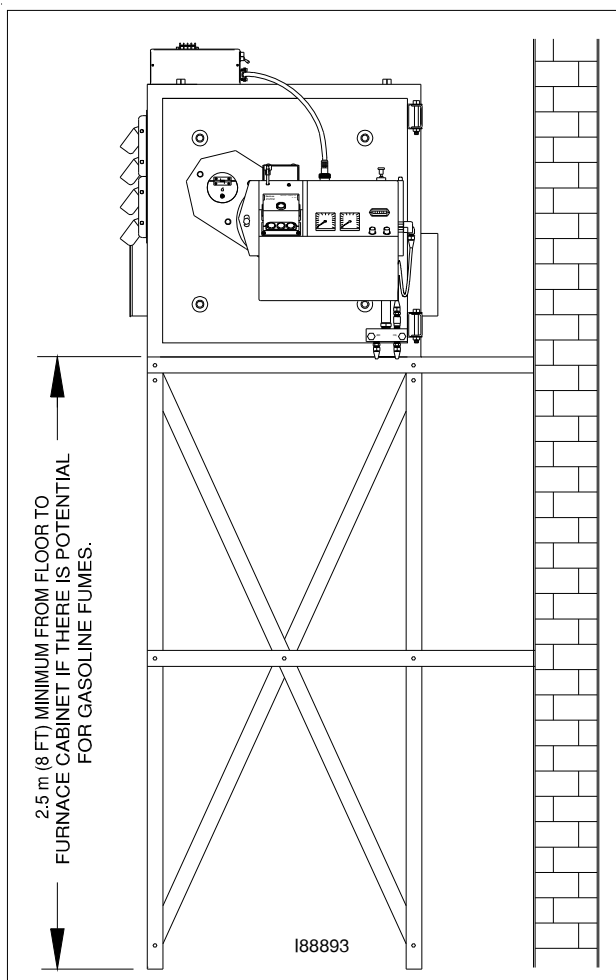

Figure 4D - CB-1500 Furnace Installed on a Raised Platform (CB-2500 is similar)

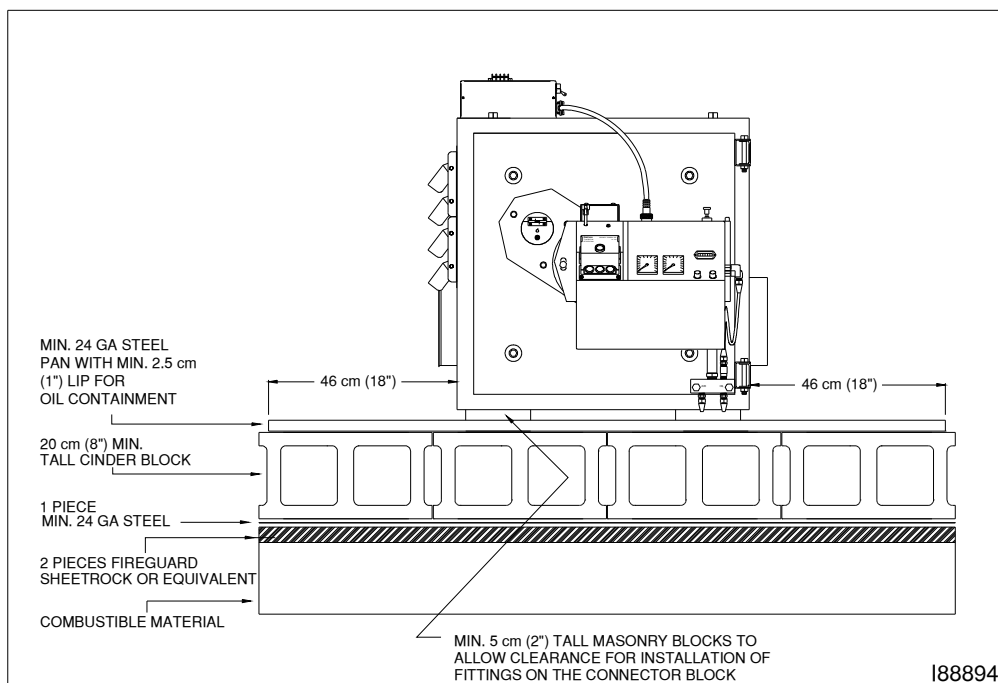

Figure 4E - CB-1500 Furnace Installed on Non-Combustible Floor (CB-2500 is similar)



Oil Tank Installation Specifications

Ensure that your tank installation adheres to the following safety guidelines as stated here and in **Section 1** of this manual.

The tank safety label (shown at right) also summarizes these important specifications for tank installation and usage. If you do not have a copy of this label, please contact your Clean Burn dealer for a copy, which is to be affixed directly to your used oil supply tank.

- **The tank installation must meet all national and local codes.** Consult your local municipal authorities for more information as necessary.
- Use a minimum **1000 Liter tank**. **DO NOT** use drums as a substitute for an appropriate tank. The tank must be large enough to allow water, sludge, etc. to settle out of the used oil.
- Single wall tanks must have a **shut-off valve** on the side of the tank to allow the water, sludge, etc. to be drained from the bottom of the tank.
- All **unused openings in the tank must be plugged** or capped off.
- For optimal system functioning, Clean Burn Recommends inside tank installations as shown in Figures 4A, 4B, and 4J.
- The tank must be **vented to the outside** of the building using iron or steel pipe and fittings with an approved vent cap.
- Carefully review the oil tank and pump installation details as shown in Figures 4A, 4B, 4F, and 4J including the metering pump installation and specifications for the oil line installation. (Procedures for installing these components can be found in the following pages.)
- Ensure that the oil supply tank is **properly maintained**; refer to Section 9 in this manual for related procedures.

WARNING

**Fire and explosion hazards.
To prevent serious injury or death:**

ONLY place these listed substances in this used-oil supply tank:

- Used crankcase oil
- Used automatic transmission fluid
- Used hydraulic oil
- #2 fuel oil

Do **NOT** place flammable or corrosive substances such as gasoline, chlorinated oils, solvents, paint thinners, or any other unsafe substances in this used-oil supply tank.

Do NOT weld or allow open flame within 35 feet of this used-oil supply tank.

Tank installation **MUST** comply with NFPA 30 and 31 Fire Codes, including the following requirements:

- Tank must be listed to UL 80 or UL 142.
- Tank must be vented to outside.
- Emergency vent or explosion relief must be installed on tank.
- Inside fill allowed only with funnel including 1/4 turn-to-close ball valve, which must be closed after filling.
- All other openings must be plugged.
- All oil lines must be constructed of copper, steel, or brass components. Do **NOT** use rubber or plastic tubing or piping, or any other inappropriate material.



**Follow all instructions
for tank installation in
Operator's Manual.**

42366

ATTENTION: For outside tank installations and/or tanks larger than 1890 Liters (500 gallons), contact the local Clean Burn distributor for installation recommendations and specifications.

Oil Tank Installation Specifications (continued)

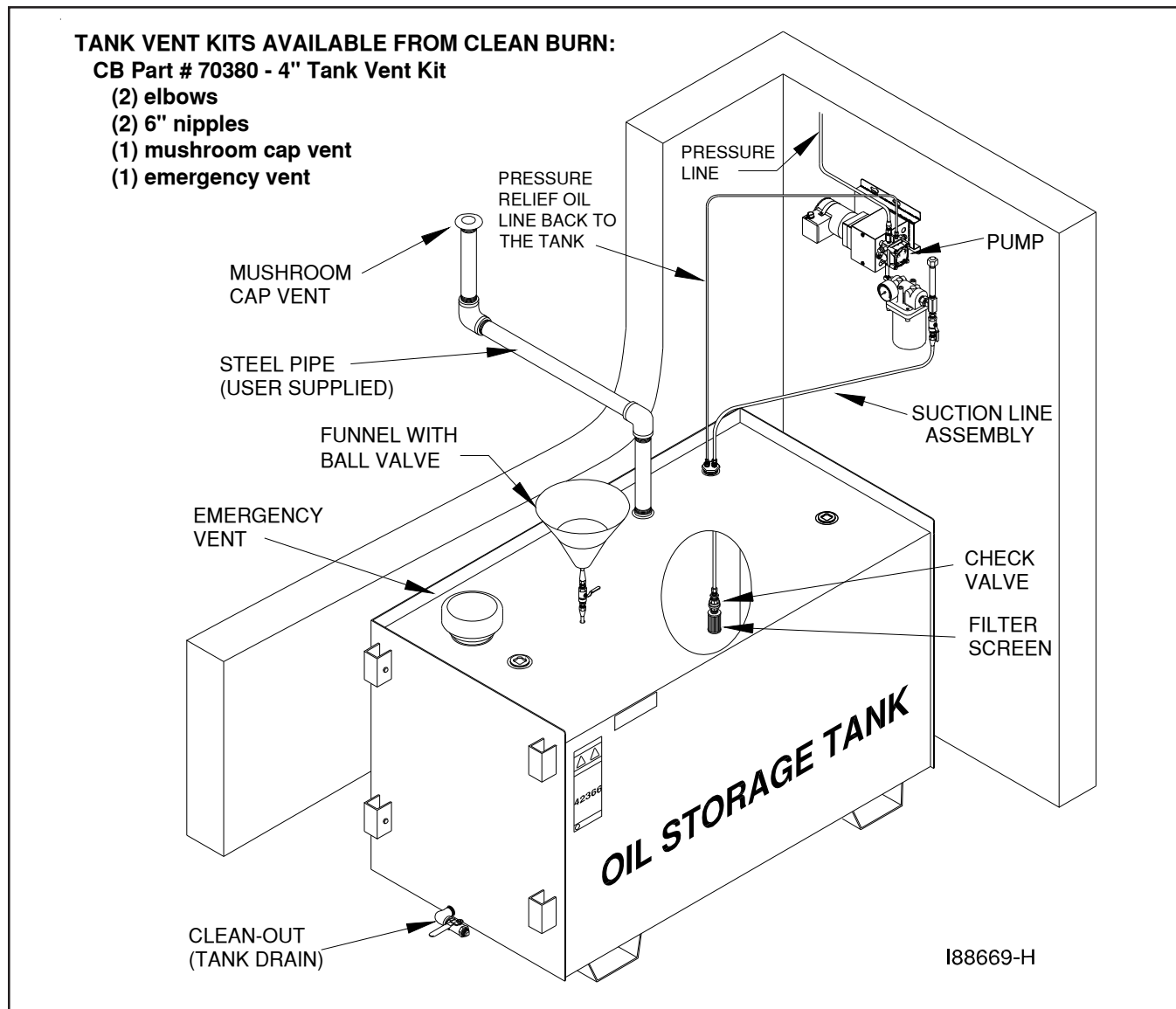

Figure 4F - Typical Metering Pump Installation with Inside Tank

Installing the Tank Vent and Emergency Vent

Codes require that you install a tank vent (to the outside) and an emergency vent for your tank as shown in Figure 4F. **Tank Vent Kits** are available from Clean Burn; contact your local Clean Burn dealer to order. Be sure to check your local codes for any additional tank installation requirements, and adhere to the following installation guidelines:

- Install a length of minimum 5 cm (2") steel pipe (user-supplied) terminating outside with a proper vent cap as shown in Figure 4F. Consult local codes for information and requirements concerning the proper venting of oil storage tanks.
- Install an emergency vent as shown in Figure 4F. Contact your tank manufacturer for information concerning the proper emergency vent for your tank.

Installing the Metering Pump

Preparing for Installation

Before starting installation of the metering pump, review Figures 4G, 4H, and 4I to become familiar with the metering pump components. You will also need to accomplish the following activities:

- Verify that you have the proper metering pump for your furnace (note the specific gear motor part numbers shown in Figure 4H).
- Gather all required tools and materials as needed for installation; as indicated in the following procedures, some materials (e.g. fittings, tubing) are to be user-supplied.
- *Standard mounting* is vertical mounting on a wall; **this pump installation is recommended.** *Alternate mounting* is horizontal mounting on a bracket. Be sure to carefully follow the appropriate procedures/diagrams for pump mounting.
- For optimal metering pump functioning, mount the pump at a distance from the oil tank that will comply with the following requirements:

The suction oil line may NOT exceed **183 cm (6') TOTAL vertical lift AND 122 cm (4') TOTAL horizontal lift.**

Standard Mounting: Vertical Positioning

1. Refer to Figures 4G, 4H, and 4I. Note that the metering pump is shipped with the pump head already positioned for vertical wall mounting.
2. Use the appropriate type of bolts and washers (user-supplied) to securely mount the metering pump to the appropriate wall in your building at a distance from the tank that complies with the suction oil line requirements.

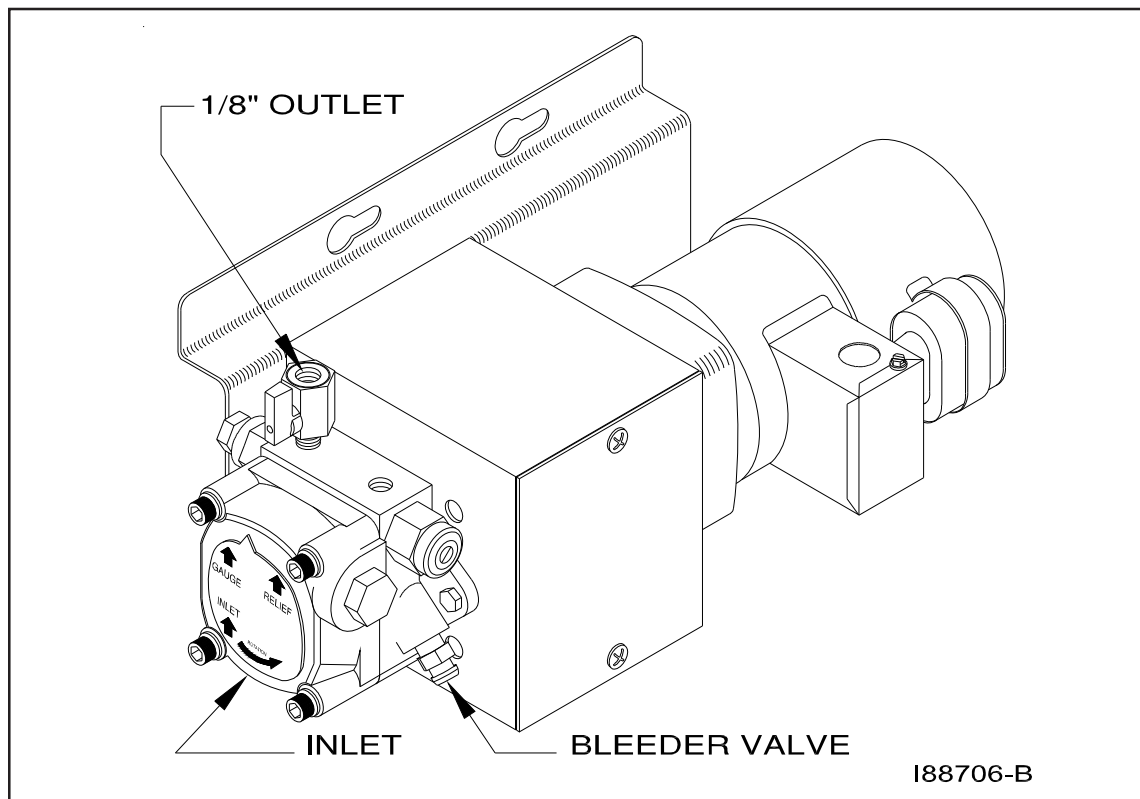
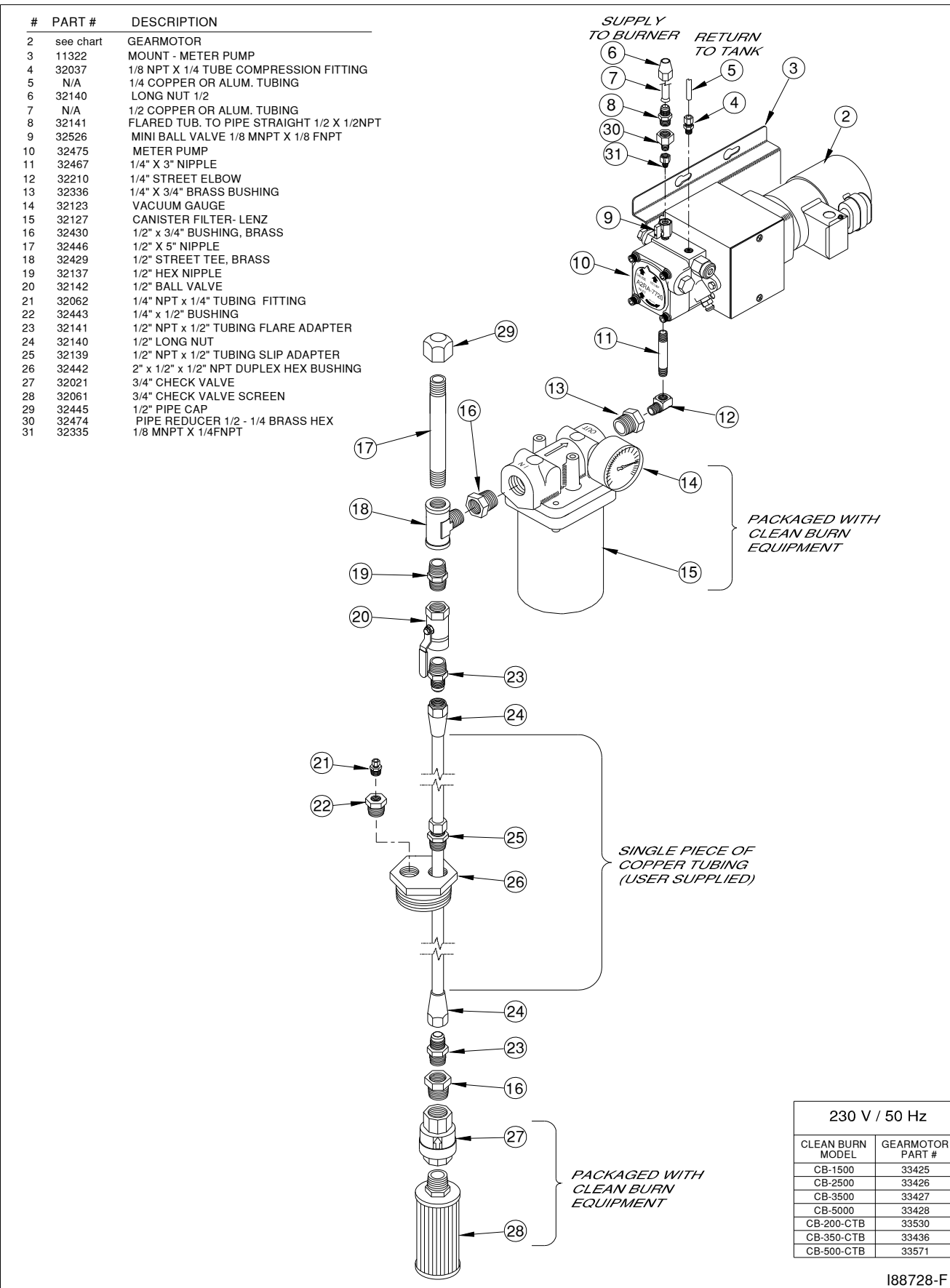

Figure 4G - Standard (Recommended) Vertical Mounting of the Metering Pump



I88728-F

Figure 4H - Metering Pump Component Detail

Installing the Metering Pump (continued)

Alternate Mounting: Horizontal Positioning

ATTENTION: If the metering pump is to be mounted horizontally or on a bracket as shown in Figure 4I, the pump head must be rotated counterclockwise so that it is aligned in a horizontal position. *The gauge arrow on the pump head must point up, or the pump will not prime.*

1. Refer to Figures 4H and 4I.
2. Remove the two pump mounting bolts. The coupling is keyed and does not have set screws.
3. Rotate the pump head 180 degrees to the horizontal position as shown in Figure 4I.
4. Re-install and tighten the two pump mounting bolts.
5. Use the appropriate type of bolts and washers (user-supplied) to securely mount the metering pump to the mounting bracket, which is to be installed on the appropriate wall in your building at a distance from the tank that complies with the suction oil line requirements.

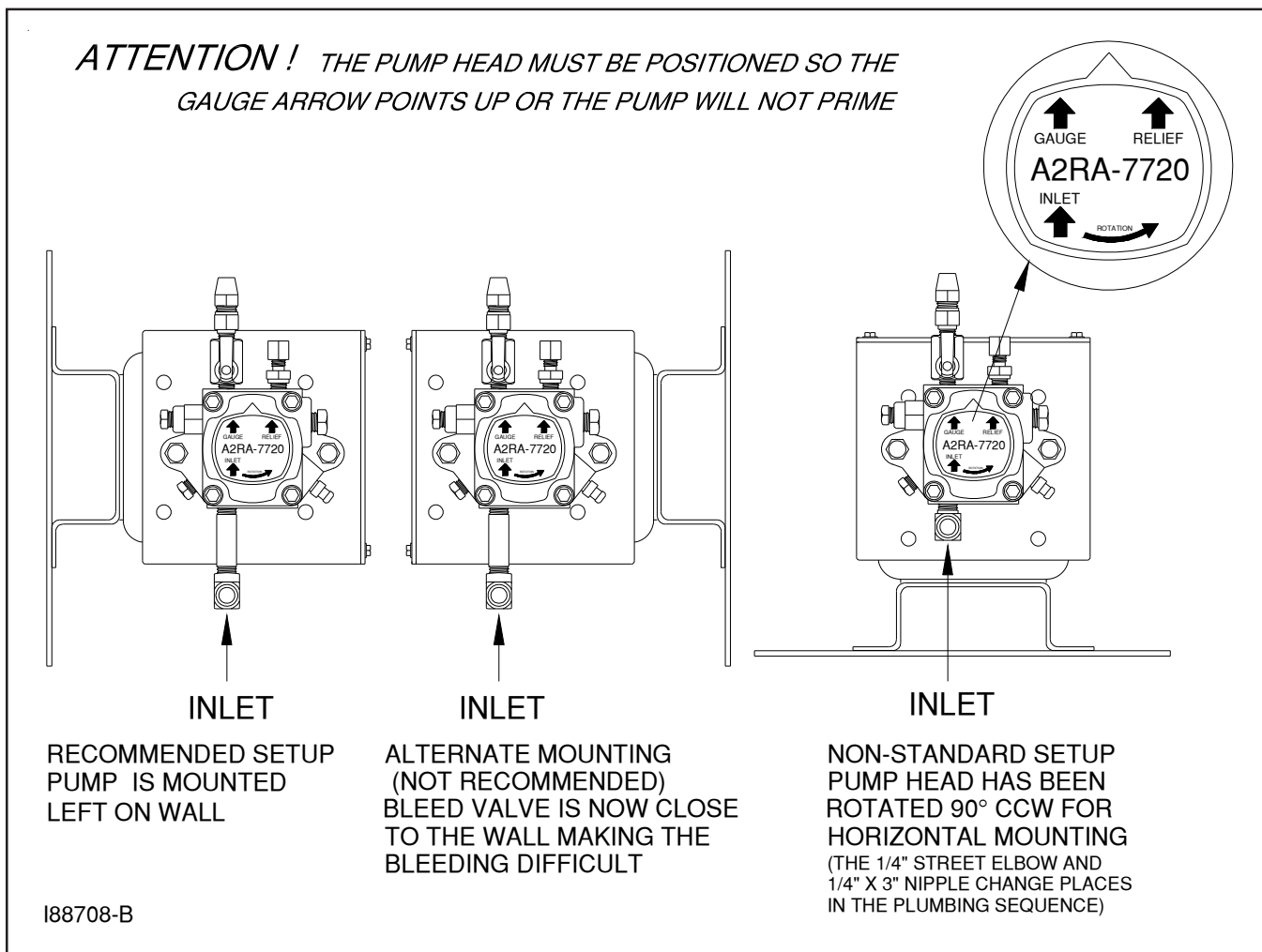

Figure 4I - Proper Positioning of Metering Pump Head

Wiring the Furnace and Pump



WARNING: To avoid electrical shock, make sure that power to the furnace is turned OFF before connecting any wires. A licensed electrician should install all wiring to your furnace. All wiring must be in accordance with national and local codes. Properly size all wires and use electrical conduit for all electrical lines.

Wiring your furnace involves the installation of two lines:

- (1) A dedicated electrical line to the furnace
- (2) A pump electrical circuit from the furnace to the metering pump

Necessary wiring specifications are provided in this section and in the **Wiring Schematics** located in **Appendix B** at the back of the manual.

Wiring to the Furnace



WARNING: A fuse-protected disconnect must be mounted in a readily accessible location for the installation of the unit. This device can also be used for a disconnect in case of an emergency.

1. Install a dedicated electrical circuit to the electrical junction box on the furnace.
WARNING: DO NOT tie into an existing circuit, or electrical overload may occur.
2. Wire the furnace according to the Wiring Schematic, Figure B1, in Appendix B. Ensure that the ground wire is attached to the green ground screw on the furnace junction box.
3. Check for correct voltage at the furnace, and refer to the following chart.
ATTENTION: Incorrect voltage will severely damage the blower motor/furnace components. DO NOT operate your furnace on any non-specification power system.

Model	Voltage	Fuse Protection*	Circuit Hertz	
CB-1500	230	15 amps	Dedicated	50
CB-2500	230	15 amps	Dedicated	50

***NOTE:** When installing any optional equipment (e.g. air compressor or draft inducer), you do not need to "upgrade" the fuse protection. **The fuse size listed above is sufficient.** Make sure a qualified electrician properly sizes and installs this electrical circuit. **14-gauge copper wire is required for 15 amp fuse protection.**

4. DONOT turn on main power until instructed to do so.

Wiring to the Metering Pump



WARNING: DO NOT wire the pump directly into your building's electrical system. The pump must be activated (receive power) from the burner via the pump electrical circuit. DO NOT wire the pump directly to a wall outlet so that it runs continuously; this will seriously damage your metering pump and/or furnace and may result in a fire or explosion hazard.

1. Install the pump electrical circuit from the furnace to the metering pump location using approved electrical conduit.
2. Wire the pump circuit according to the **Metering Pump Wiring Schematic** in Appendix B at the back of this manual.

Installing the Suction Oil Line Components

ATTENTION: It is critical that you adhere to the following specifications for suction oil line installation (*oil line from the tank to the pump*). If these specifications are not met, the metering pump will not function correctly and the burner will shut down on reset. The majority of service problems with the metering pump are caused by leaks at fittings in the suction oil line; these problems are eliminated by ensuring a 100% airtight suction oil line which slants up to the pump.

- All suction oil line components must be installed as shown in Figures 4H and 4J. **Suction line size is 13 mm (1/2") diameter.** Proper installation allows the suction oil line to be filled with used oil during initial priming.
- The suction oil line may NOT exceed **183 cm (6') TOTAL vertical lift AND 122 cm (4') TOTAL horizontal lift** (*which equals 6.0" hg maximum operating vacuum*). To determine if your suction oil line will meet this specification for maximum operating vacuum, base the calculation for your installation on the following equivalents:

30 cm vertical (1') = 0.75" hg (vacuum)

122 cm horizontal (4') = 0.75" hg (vacuum)

NOTE: ALSO ADD 0.75" hg to the final sum to account for every oil filter, shut-off valve, and check valve on the suction side of the pump assembly.

Sample calculation: 183 cm (6') vertical x (0.75" hg/30 cm) = 4.50" hg AND

122 cm (4') horizontal = 0.75" hg

4.50" hg + 0.75" hg + 0.75" hg = 6.00" hg vacuum

- The metering pump must be installed with a **3/4" check valve and screen** at the end of the suction oil line, or the pump will not maintain its prime.
 - Use **Permatex #2 non-hardening gasket sealer** on every threaded fitting. DO NOT use teflon tape or teflon pipe dope compounds; the teflon can flake off and cause damage to the pump head.
 - **The suction oil line must be 100% airtight for proper system functioning.** Use only high-quality flare fittings for the copper tubing. DO NOT use compression fittings. DO NOT use any steel pipe unions. DO NOT use sweat copper pipe. These types of fittings cause air leaks in the suction oil line and will require re-installation.
 - **The suction oil line must slant up to the pump;** any high spots will trap air and will not allow the pump to prime.
1. **Assemble the suction oil line fittings (*from the metering pump to the canister filter*):**
 - a. Refer to Figure 4H for a detailed look at the metering pump components and fittings.
 - b. Remove the plug from the 1/4" inlet port of the pump.
 - c. Install the 1/4" x 3" brass nipple into the 1/4" inlet port on the pump.
 - d. Install the 1/4" brass street elbow onto the 3" brass nipple; turn the fitting onto the nipple until it is tight and faces away from the pump mounting plate.
 - e. Prepare the canister filter for installation:
 - Install the 3/4" x 1/4" brass hex bushing into the outlet port of the canister filter. *Check the direction of the arrow for the proper flow.*
 - Install the 3/4" x 1/2" brass bushing into the inlet port of the canister filter.
 - Remove the plug from one of the 1/8" gauge ports in the canister filter and install the vacuum gauge. Seal the threads of the gauge with Permatex #2 non-hardening gasket sealer.
 - Install the 1/2" threaded pipe adapter into one side of the 1/2" ball valve.
 - Install the 1/2" MPT x 1/2" flare adapter into the other side of the ball valve.

Installing the Suction Oil Line Components (continued)

- (1.) (e.) Prepare the canister filter for installation (*continued*):
- Install this assembly into one side of the 1/2" brass tee.
 - Install the assembled 1/2" tee into the 3/4" x 1/2" brass bushing, which is installed in the inlet port of the canister filter. Make sure that the 1/2" flare adapter is pointing down.
 - Install the canister filter assembly onto the 1/4" brass street elbow as shown in Figure 4H. The canister filter must be installed with the arrow pointing towards the pump (direction of oil flow).
 - Install the 1/2" x 5" brass nipple into the top side of the 1/2" brass tee assembly.
 - Loosely install the 1/2" brass cap onto this nipple. **DO NOT** tighten the cap at this time.

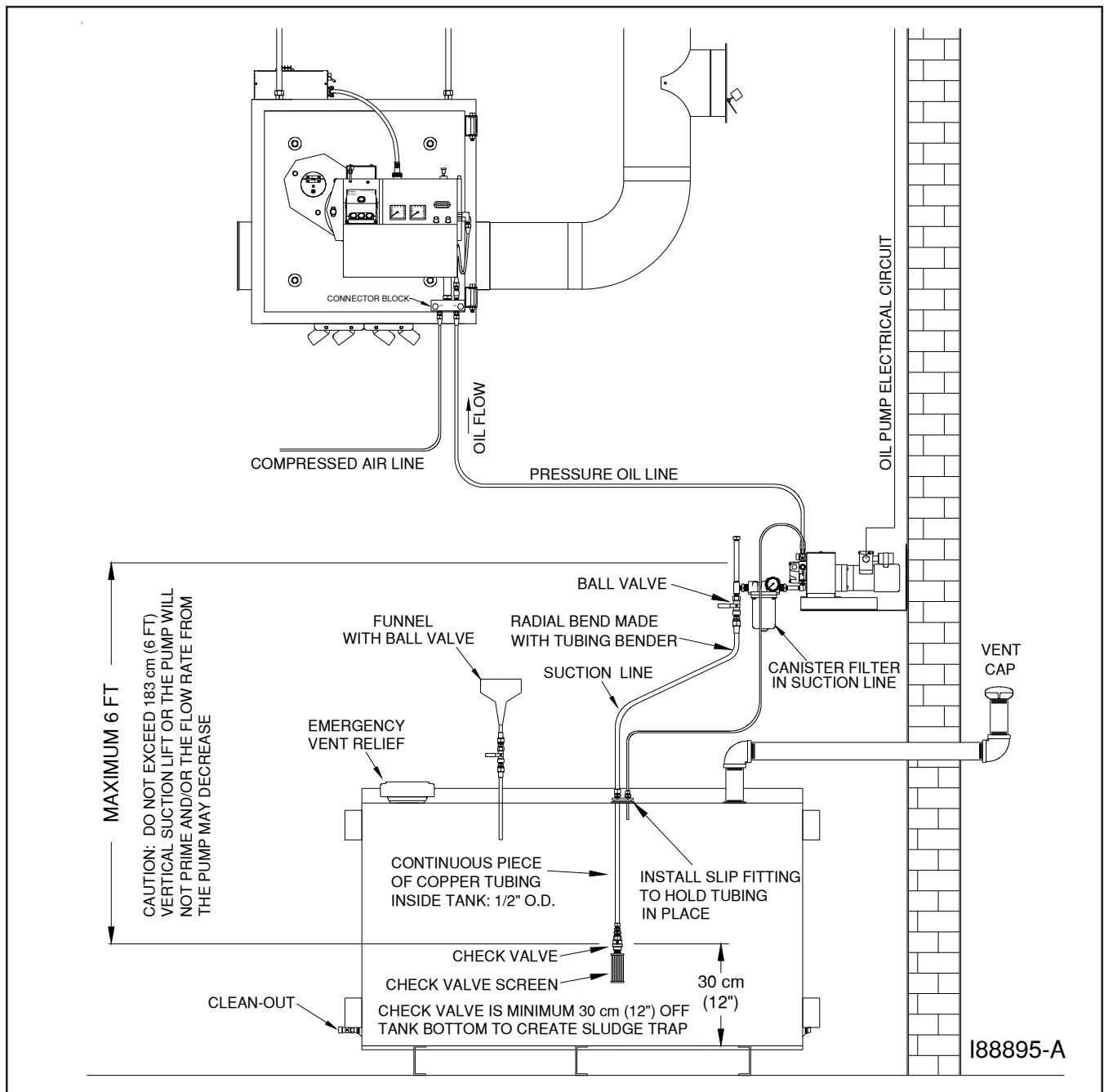

Figure 4J - CB-1500 Oil Line Installation Overview (CB-2500 is similar)

2. **Install the suction oil line (from the the tank to the canister filter):**
- a. Refer to Figures 4H and/or 4J.
 - b. Prepare a piece of 1/2" O.D. copper tubing (user-supplied) which will function as the pick-up line from the tank to the canister filter. This copper tubing must have the following specification
 - The tube must be one continuous piece of 1/2" O.D. copper tubing with no kinks or fittings.
 - The tube is to slant up from the tank to the pump with no loops or high points to trap air.
 - c. Locate the 2" MPT x 1/2" FPT x 1/2" FPT duplex, slip-thru hex bushing (which will eventually be installed into one of the 2" openings on the tank). *Note that the fitting is marked "S" for suction and "R" for return.*
 - d. Install the 1/2" MPT x 1/2" slip fitting into the "S" side of the 2" duplex slip-thru hex bushing.
 - e. Install the 1/4" MPT x 1/4" compression fitting into the 1/2" x 1/4" brass bushing.
 - f. Install the 1/2" x 1/4" brass bushing into the "R" side of the 2" duplex slip-thru hex bushing.
 - g. Measure the height of the oil tank (from the bottom of the tank, NOT the floor) to the 2" opening that you are going to use for the supply oil line. Deduct 12" (305mm) from this measurement and transfer this new measurement onto the 1/2" O.D. copper tubing.
 - h. Remove the locking nut and ferrel sleeve connector from the 1/2" slip fitting, and slide them over the copper tubing.
 - i. Slide the 1/2" O.D. copper tubing through the 1/2" slip fitting, which is installed in the "S" side of the 2" hex bushing.
 - j. Install the screen into one side of the 3/4" check valve (making sure the arrow is pointing away from the screen assembly).
 - k. Install the 3/4" x 1/2" brass bushing into the 3/4" check valve.
 - l. Install the 1/2" MPT x 1/2" flare adapter into the 3/4" x 1/2" brass bushing.
 - m. Slide the 1/2" flare nut over the end of the 1/2" copper tubing, and flare the end of the tubing. **NOTE:** Use a high-quality flaring tool (such as a Ridgid Flaring Tool) to ensure that all flares are made properly (i.e. so they will be 100% airtight).
 - n. Install the flared oil line and nut onto the assembled check valve/screen and tighten.
 - o. Pick up the assembled oil line, and carefully guide the end of the tubing with the check valve through the 2" tank opening.
 - p. Apply Permatex #2 non-hardening gasket sealer (or equivalent) to the threads of the 2" duplex slip-thru tank bushing, and tighten this fitting into the tank.
 - q. Pull the 1/2" copper tubing back up through the slip fitting until you see the mark that you put on the tubing earlier. Holding the tubing with one hand, push the ferrel sleeve connector and locking nut down the tubing, then tighten onto the 1/2" slip fitting. The oil line is now installed in the correct position off of the bottom of the tank.
 - r. Carefully bend the oil line up to the canister filter; use a spring bender over the oil line while bending the tubing to prevent kinks in the oil line. Allowing for the flare nut, cut off the excess tubing.
 - s. Install the 1/2" flare nut onto the tubing, and flare the end of the tubing.
 - t. Install the end of the tubing with the flare nut onto the 1/2" flare adapter (on the ball valve assembly at the canister filter).
 - u. Install a vent from the tank to the outside of the building according to code. The tank must be properly vented to allow air to enter the tank as oil is pumped out and to safely vent fumes to the outside. See Figure 4J.
 - v. Install plugs in all other tank openings as required by code.
 - w. Inspect the installation. For proper suction oil line operation, make sure all components are installed and positioned as specified in this manual.

Installing the Pressure Relief Oil Line Back to the Tank

ATTENTION: It is critical that you adhere to the following specifications for plumbing the pressure relief back to the tank.

The metering pump requires the installation of a pressure relief oil line back to the tank that you are pulling oil from as shown in Figures 4H, 4J, and 4K.

- The **pressure relief** will open and relieve pressure if there is a restriction in the pressure oil line, clogged nozzle, etc.

Be sure to use Permatex #2 non-hardening gasket sealer to seal every threaded fitting. **DO NOT** use teflon tape or teflon pipe dope compounds.

1. Refer to Figure 4K.
2. Remove the plug from the relief port on top of the metering pump head.
3. Install the 1/8 NPT x 1/4 tube compression fitting in the relief port on top of the metering pump head.
4. Install 1/4" O.D. copper tubing (user-supplied) from the pressure relief port back to the oil tank. Refer to Figure 4J as needed.

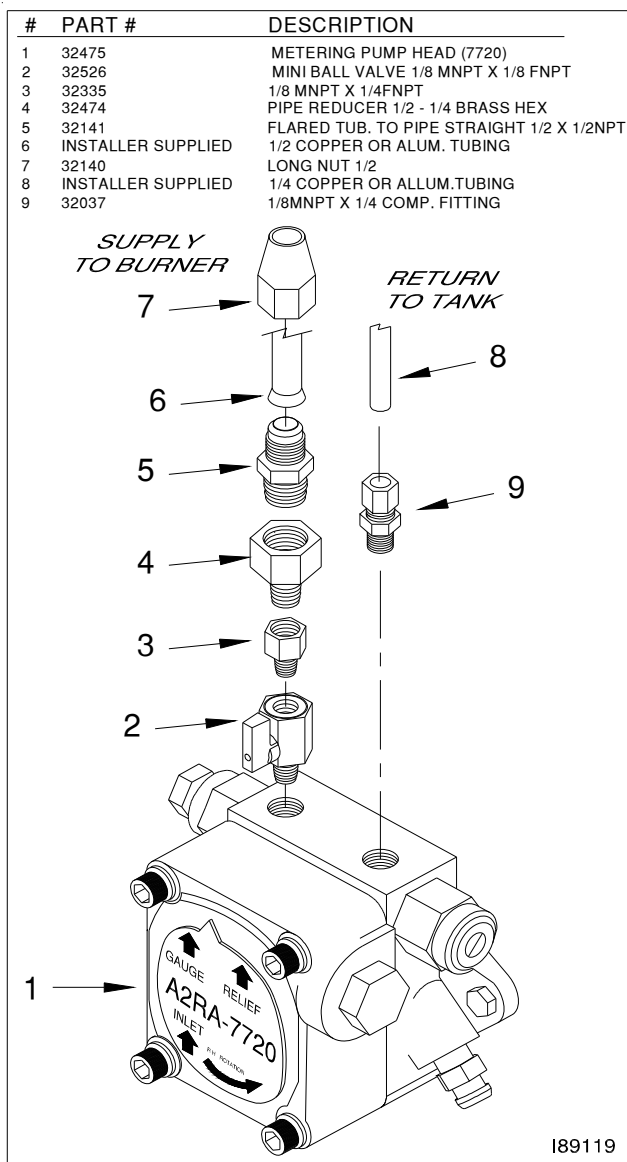

Figure 4K - Installing the Pressure Relief Oil Line Back to the Tank

Installing the Pressure Oil Line Components

ATTENTION: It is critical that you adhere to the following specifications for pressure oil line installation (oil line from the pump to the furnace); if these specifications are not met, the metering pump will not function correctly and the burner will shut down on reset.

The parameters for pressure oil line installation are:

<u>Length of Pressure Line</u>	<u>Line Size</u>
Up to 30 m (100') (Please note that some installations will allow for a greater pressure line length. Contact your Authorized Clean Burn Distributor for more information.)	10 mm (3/8") O.D. copper tubing
<ul style="list-style-type: none"> • The pressure oil line must slant up to the burner with no loops or high points to trap air. • Local codes may require the installation of an in-line "Fire-O-Matic" safety valve. Be sure to check all appropriate codes to ensure compliance. 	

1. Refer to Figures 4H, 4J, and 4K.
2. Make sure you have purchased all the necessary fittings to complete the installation correctly.
3. Install the fittings and components as shown in the related illustrations.
4. Be sure to use permatex #2 non-hardening gasket sealer to seal every threaded fitting. Do not use teflon tape or teflon pipe dope compounds.

Installing the Compressed Air Line

NOTE: Your air compressor system must supply air pressure to the furnace with the following requirements: At least **1.7 bar (25 psi)** and a **water trap or dryer**. If you do not have shop air, an optional air compressor is available. Contact your local Clean Burn dealer for more information.

1. Run a compressed air line from your shop air to the connector block on the furnace. Use minimum 6 mm (1/4") O.D. copper tubing or equivalent for the compressed air line.
2. Install an easily accessible shut-off valve in the air line so the burner can be serviced without shutting off the shop air in your service area.
3. If necessary, install a pressure regulator (additional to the burner air regulator) in the air line, and set it at 3.5 bar (50 psi).
ATTENTION: DO NOT feed full shop air pressure to the burner or damage to burner components may occur.
4. Install a water trap or extractor/dryer in the air line with an automatic drain so compressed air (rather than water) is supplied to the burner.
ATTENTION: Water must not be fed to the burner, or the flame will be extinguished and the burner will shut down. Be sure to drain water from your compressor tank on a regular basis to keep water out of the air line.

Installing the Stack



WARNING: Inappropriate stack materials or improper stack design/installation can adversely affect the proper, safe operation of your furnace. Contact your Clean Burn dealer to purchase the proper stack components for your furnace.

Stack designs are generally classified as follows:

- (1) "Class A" stack through the ceiling of the building. Refer to Figure 4L.
- (2) "Class A" stack through the sidewall and up the side of the building. Refer to Figure 4M.

Stack Design and Specifications

ATTENTION: *The stack design must be single and dedicated for each unit (furnace) according to the following specifications.* A single stack serving more than one unit **MUST** be engineered/certified for that specific installation. Failure to adhere to this rule may result in less than optimal system performance.

Figures 4L and 4M illustrate these stack designs. Choose the stack design which is appropriate for your furnace installation and review all specifications provided in the related illustrations. When designing your stack, adhere to the following specifications:

- Models CB-1500 and CB-2500 require minimum 203 mm (8") I.D. stack components.
- *Ensure that the vertical stack height is at least 3 m (10 feet).* If needed, increase the vertical length of the stack or install a draft inducer to obtain -.02" W.C. draft over fire.
- *Keep the horizontal stack run as short as possible; slant it upward at a minimum of 6.5 mm (1/4") per 305 mm (12") of run.*
- *Keep the stack design simple.* Complicated stacks (with long runs and many turns) reduce draft and result in poor burner performance. Your stack may include only one 90 degree turn. All other stack turns must be at 45 degrees or less to ensure optimal draft and burner performance.

NOTE: If you plan to use an existing masonry chimney, the chimney must be lined and inside the building. Exterior masonry chimneys chill the stack gases and result in poor draft and poor burner performance.

ATTENTION: *If you have an exhaust fan(s) in your shop, it is critical that you have adequate make up air (source of fresh air to replace the stale air exhausted by the fan).* When an exhaust fan is run without adequate make up air, the resultant vacuum in the building will draw combustion products back into the burner. This back draft causes poor burner performance and may damage vital burner components. Refer to Section 8 in this manual for additional information.

Stack components should be installed in the following order:

- (1) Inside stack (from furnace breach to within 45 cm (18") of ceiling, roof, or sidewall of building)
- (2) Barometric damper
- (3) "Class A" stack penetration through the ceiling, roof, or sidewall
- (4) "Class A" stack on the exterior of the building
- (5) "Class A" stack cap

Installing the Stack (continued)

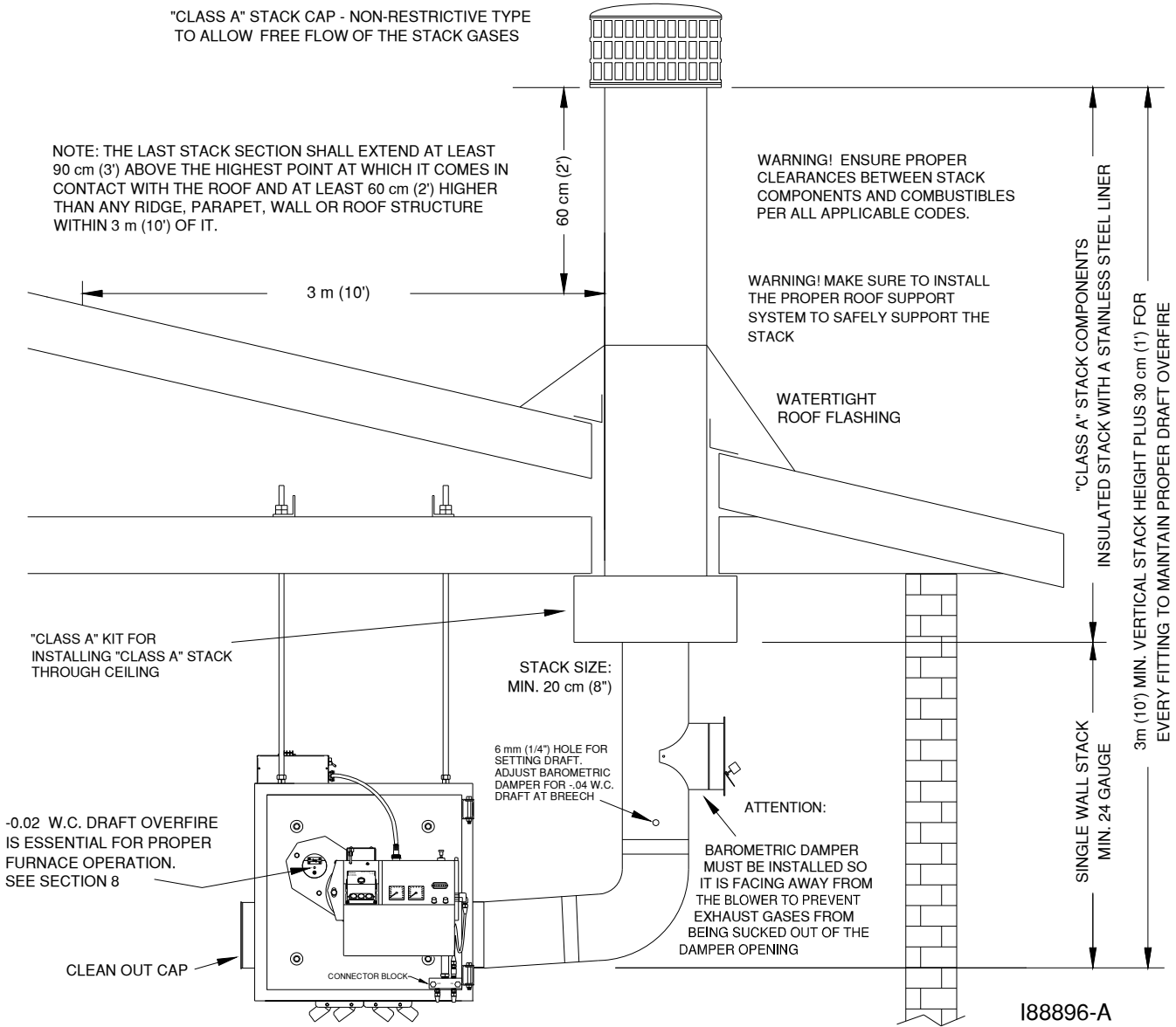

Figure 4L - CB-1500 Installation of "Class A" Stack Through Roof/Ceiling (CB-2500 is similar)

Installing the Stack (continued)

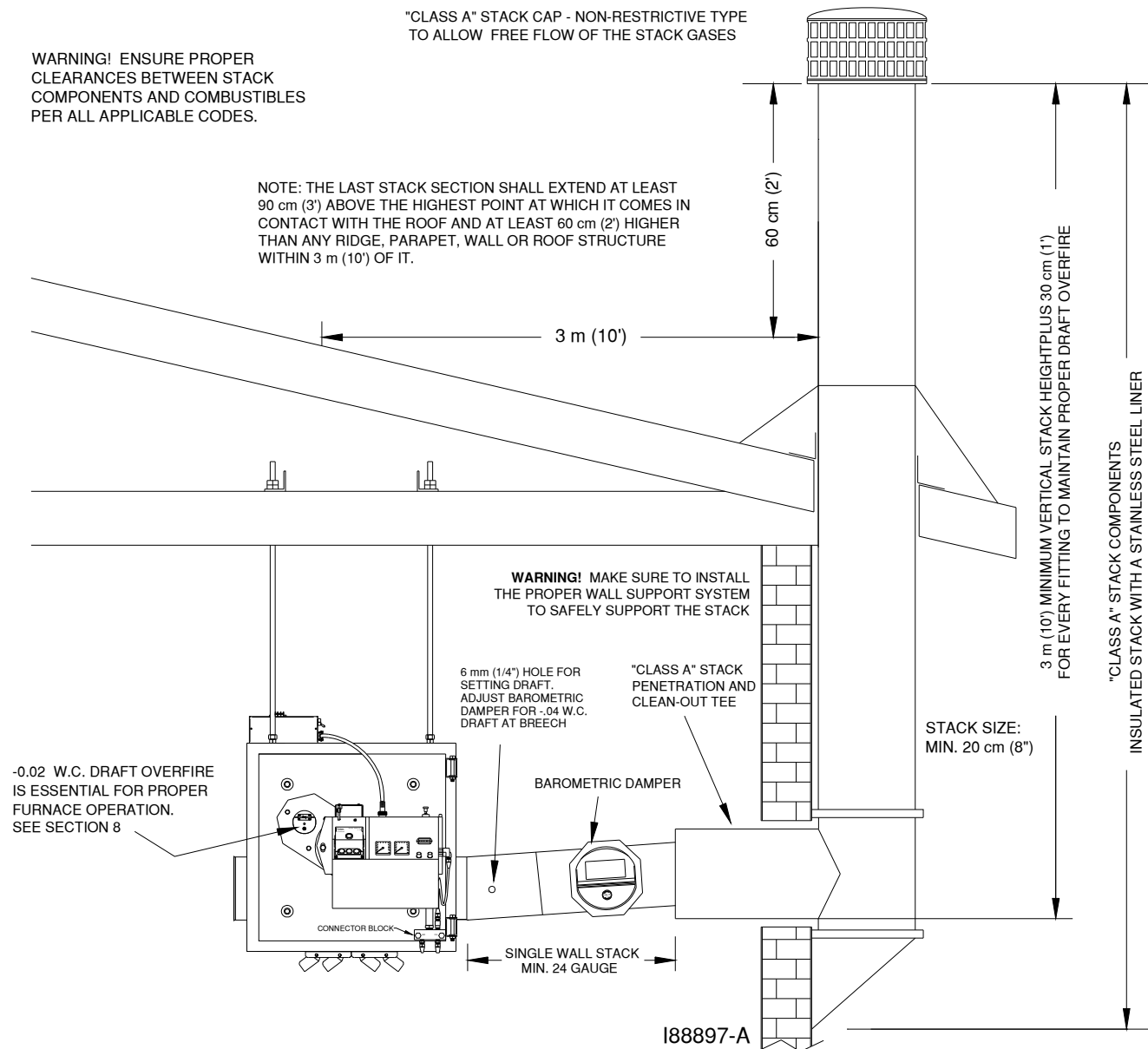

Figure 4M - CB-1500 Installation of "Class A" Stack Through Sidewall
(CB-2500 is similar)

Installing the Interior Stack



WARNING: Single wall stack components may be used *only* for those portions of the stack which are located inside your building and away from any fire/burn hazards.

1. Install the single wall stack with proper clearances from combustibles. Also ensure that the stack is located a safe distance from all shop personnel.
2. Install an elbow or clean-out tee at the junction of the horizontal and vertical stack components to allow for easy cleaning of the stack.

ATTENTION: Avoid additional 90-degree turns in the stack. Each additional 90-degree turn slows down stack gases, creates back-pressure, and results in repeated burner shutdown and unnecessary service calls. All other turns in the stack should be at a 45-degree (or smaller) angle.

NOTE: Local codes may require the installation of a clean-out tee.

Installing the Barometric Damper

1. Refer to Figure 4L. Install a single wall tee (min. 24 gauge) after the 90-degree elbow in the straight vertical stack section within 90 to 150 cm (3 to 5 feet) of the furnace breach. For horizontal stack runs (Figure 4M) install the tee after the first straight section of pipe.

NOTE: This tee is required to support the barometric damper. You must purchase this tee when you purchase your stack materials (8" single wall tee - CB#70174).

2. Refer to Figure 4N. Install the barometric damper in the opening of the tee. Use a small spirit level to make sure that it is properly level.
3. Install two self-tapping screws as shown in Figure 4N (i.e. one on each side of the barometric damper) to hold the damper in place. **DO NOT** install a screw at the bottom of the barometric damper, or the flapper of the damper will not operate correctly.

NOTE: Specifications for adjusting the barometric damper for proper draft overfire are provided in **Section 8** of this manual.

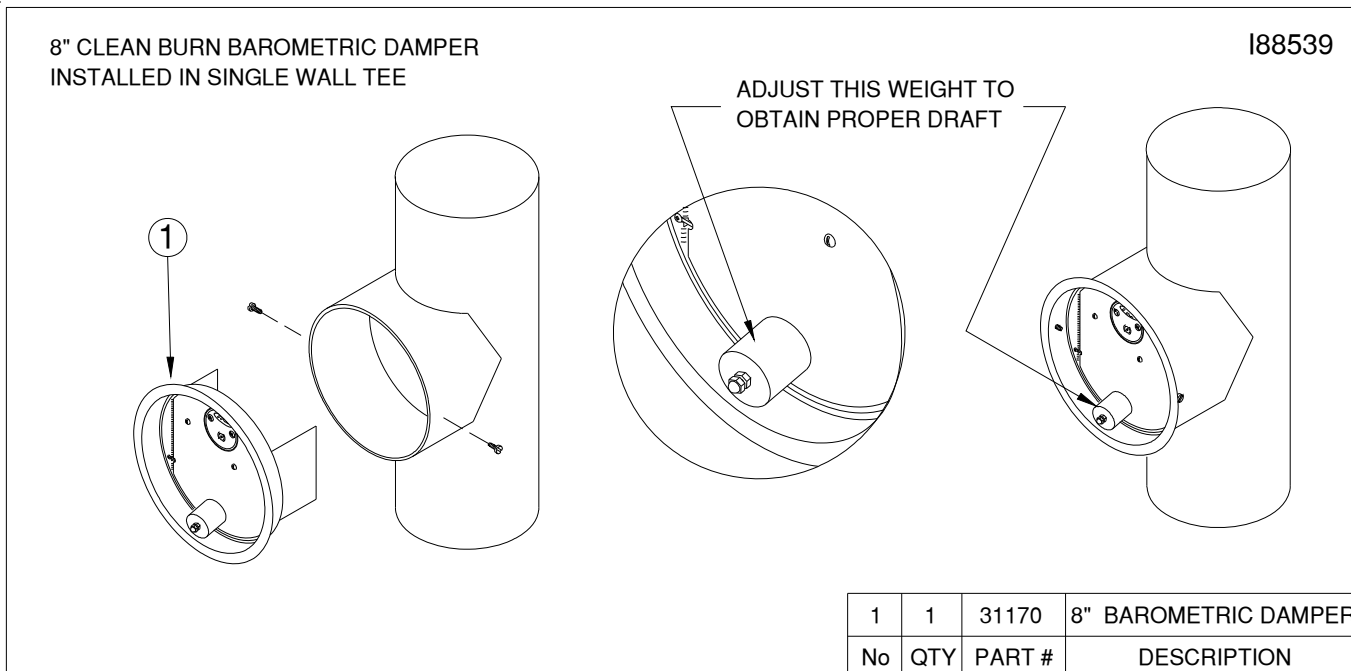

Figure 4N - Installation of Barometric Damper

Installing the Stack Penetration



WARNING: When running the stack through your ceiling, roof, or sidewall, you must use a proper insulated "Class A" stack penetration with a stainless steel liner. **DO NOT** run single-wall stack through your ceiling, roof or sidewall. Single-wall penetrations do not meet safety codes and may create a fire hazard. Never locate a stack joint inside walls or in a joist spacer. Ensure proper clearances to combustibles per all applicable codes.

1. Refer to Figure 4L/4M as needed.
2. Follow the installation instructions provided by the stack manufacturer.

Installing the Exterior Stack

ATTENTION: All exterior stack pieces must be double-wall insulated all-fuel stack components with a stainless steel liner.

- **DO NOT** use Class B or BW Vent/double-wall stack components (for gas fired appliances only).
- **DO NOT** use Type L Vent/double-wall stack components (for approved fuel oil appliances only).
- **DO NOT** use black stack pipe (for solid fuel burning appliances only).
- **DO NOT** use single-wall stack for your exterior stack. Single-wall exterior stack chills the stack gases and results in poor draft and poor burner performance.

1. Refer to Figure 4L/4M as needed.
2. Follow the installation instructions provided by the stack manufacturer.
3. Install water-tight roof flashing around the penetration of the exterior stack.

NOTE: Clean Burn recommends the use of "Dektite" roof flashing (or equivalent) which ensures a water-tight seal when installed properly. Contact your local Clean Burn dealer for details.

Installing the Stack Cap

NOTE: Proper installation of a "Class A" stack cap ensures the free flow of stack gases which is essential for optimal burner performance.

1. Refer to Figure 4L/4M as needed. Your stack cap should be classified as: "Class A" non-restrictive, All-Fuel type.
2. Install the stack cap according to the manufacturer's instructions.

Installing the Optional Draft Inducer

ATTENTION: The draft inducer, Field brand model DI-2, is optional equipment and may be installed to ensure proper draft. The Field brand draft inducer has been tested for use on Clean Burn furnaces. **DO NOT** use other models or brands of draft inducers.

Understanding the Importance of the Draft Inducer

The draft inducer is designed to aid in the removal of the natural draft created by the appliance to vent the combustion gases to the outside of the building. As the paddle wheel turns, a negative pressure is maintained within the stack so that the combustion gases can leave the furnace and travel out of the stack. (See Figure 4O.) *Proper sizing, installation, and adjustment of the draft inducer are critical for optimal draft inducer operation.*

Installing the Optional Draft Inducer (continued)

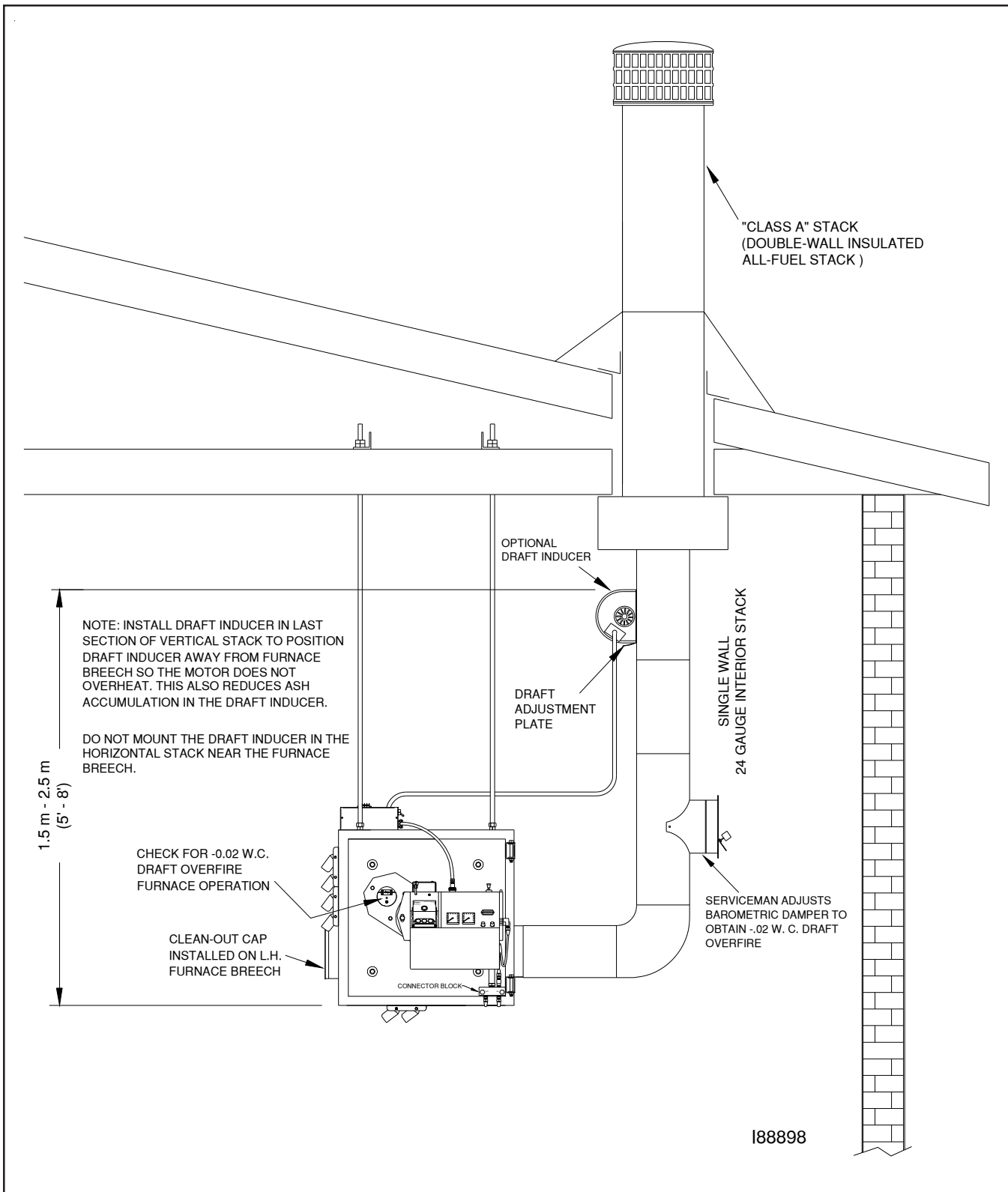

Figure 40 - Installation of the Optional Draft Inducer on the CB-2500 (CB-1500 is similar)

Installing the Optional Draft Inducer (continued)

Installing the Draft Inducer



WARNING: Turn OFF the main power to the furnace before proceeding with the installation of the draft inducer.

ATTENTION: It is very important to install the draft inducer on a vertical section of stack to isolate the inducer from excessive heat and ash buildup. Never install the draft inducer on a horizontal section of stack close to the furnace breach where heat and ash will damage the inducer motor.

1. Refer to Figure 4O. Follow the instructions included with the draft inducer to mount the draft inducer on the section of single-wall vertical stack.
2. Position the draft plate all the way out so that it does not reduce the draft produced by the draft inducer. You will adjust the draft plate later as part of **Adjusting the Draft Overfire** (Section 8).

Wiring the Draft Inducer for Normal Operation*

*(No exhaust fans in the building. If exhaust fans do exist in the building, refer to pages 8-3 to 8-6.)

1. Wire the draft inducer according to the Furnace Wiring Diagram provided in **Appendix B** at the back of this manual.

Installing the Wall Thermostat

1. Select a location for the thermostat on an interior wall away from any hot or cold drafts.
2. Remove the top cover from the thermostat by pushing gently on the latch on the right side of the case. *(Hold the thermostat base in one hand, and grasp the cover with the other hand; push in on the latch with your thumb, and pull the cover away from the base.)*
ATTENTION: DO NOT use a screwdriver to pry the cover off the base, or damage may occur.
3. Remove the black plastic tab located in the battery compartment.
4. Refer to the **Furnace Wiring Diagram** in **Appendix B** at the back of this manual. Run two wire, 18-gauge (minimum) thermostat cable from the terminals on the back of the thermostat base to the terminal block located on top of the electrical junction box (on top of the furnace cabinet).
ATTENTION: NEVER jump between terminals of the thermostat wire without removing one of the wires. Failure to remove one of the wires will burn out the heat anticipator on the thermostat and will cause the thermostat to fail.
5. Mount the thermostat base 152 cm to 168 cm (60" to 66") from the floor using the hardware provided.
6. Re-assemble the thermostat cover onto the base. *(Align the hinges on the side of the cover with the slots on the base, and swing the cover into place.)*

Inspecting the Furnace Installation

Following completion of all installation activities described in this chapter, the furnace should be inspected by qualified personnel before firing. This ensures that your installation meets all applicable national and local codes and allows for any deficiencies to be corrected before furnace startup.

SECTION 5: METERING PUMP PRIMING

Understanding Metering Pump Priming

Preparing your Clean Burn furnace for operation begins with priming the metering pump. The procedures in this section must be performed in sequence *without interruption* to properly prime the pump.

Required Tools and Materials

The following tools and materials are required for oil pump priming and should be gathered before starting any procedures:

- 3/8" open-end wrench
- 5/8" open-end wrench
- Rags
- Two containers (minimum one-gallon)
- Permatex #2 non-hardening gasket sealer
- Adjustable Wrench
- Pipe Wrench

Priming the Metering Pump

ATTENTION: *The priming process must be done precisely as described in this procedure to ensure that all air is thoroughly bled from the system.* Failure to bleed all air from the system will result in repeated burner shutdowns on reset.

1. Refer to Figure 5A.
2. Remove the 1/4" NPT plug from the side of the pump head, and set it aside.
3. Remove the 1/2" brass cap from the 1/2" brass nipple. Place a funnel in the opening. Slowly pour used oil into the funnel until oil comes out of the side of the pump head; this will fill the oil line, canister filter, and pump head with oil.
ATTENTION: NEVER run the pump head dry (i.e. without oil in the pump head); doing so will severely damage the pump.
4. Apply Permatex #2 non-hardening gasket sealer to the threads of the plug (removed from the pump head). Re-install the plug and tighten.
5. Apply Permatex #2 non-hardening gasket sealer to the threads of the 1/2" brass nipple. Re-install the 1/2" brass cap on the brass nipple and tighten.
6. Open the bleeder valve on the pump two to three (2-3) full turns, and position a container to catch oil which will flow from the bleeder during pump priming.
7. Close the mini ball valve at the outlet port of the pump head.
ATTENTION: Verify that the relief oil line is installed back to the tank before closing the mini ball valve. Closing the mini ball valve will cause the internal pump relief valve to open.

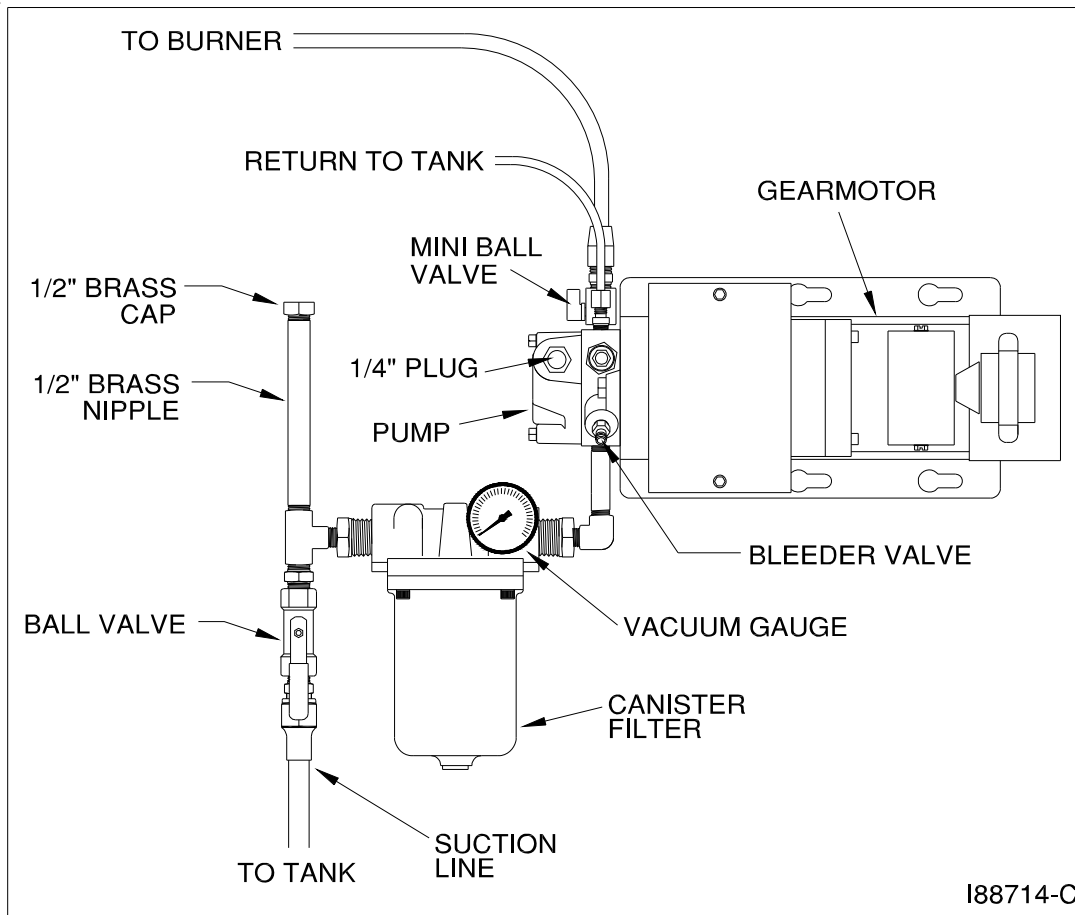

Figure 5A - Priming the Metering Pump

Priming the Metering Pump (continued)

8. Activating the Pump

NOTE: The furnaces features a priming switch which is mounted on the right-hand side of the electrical junction box on the front of the furnace cabinet. The priming switch has two positions:

- **PRIME:** This is used only for pump priming. When the switch is in the PRIME position, the pump circuit is activated for priming. The pump will continue to run as long as the switch is in this position. The oil primary control circuit is de-activated so the burner cannot run while the switch is in the PRIME position.
 - **BURNER:** This is used for normal burner operation. When the switch is in the BURNER position, the burner controls the operation of the pump. The pump will only run while the burner is running.
- a. Refer to Figure 5B to locate the priming switch.
 - b. Turn the priming switch to the prime position. The pump should immediately start running.

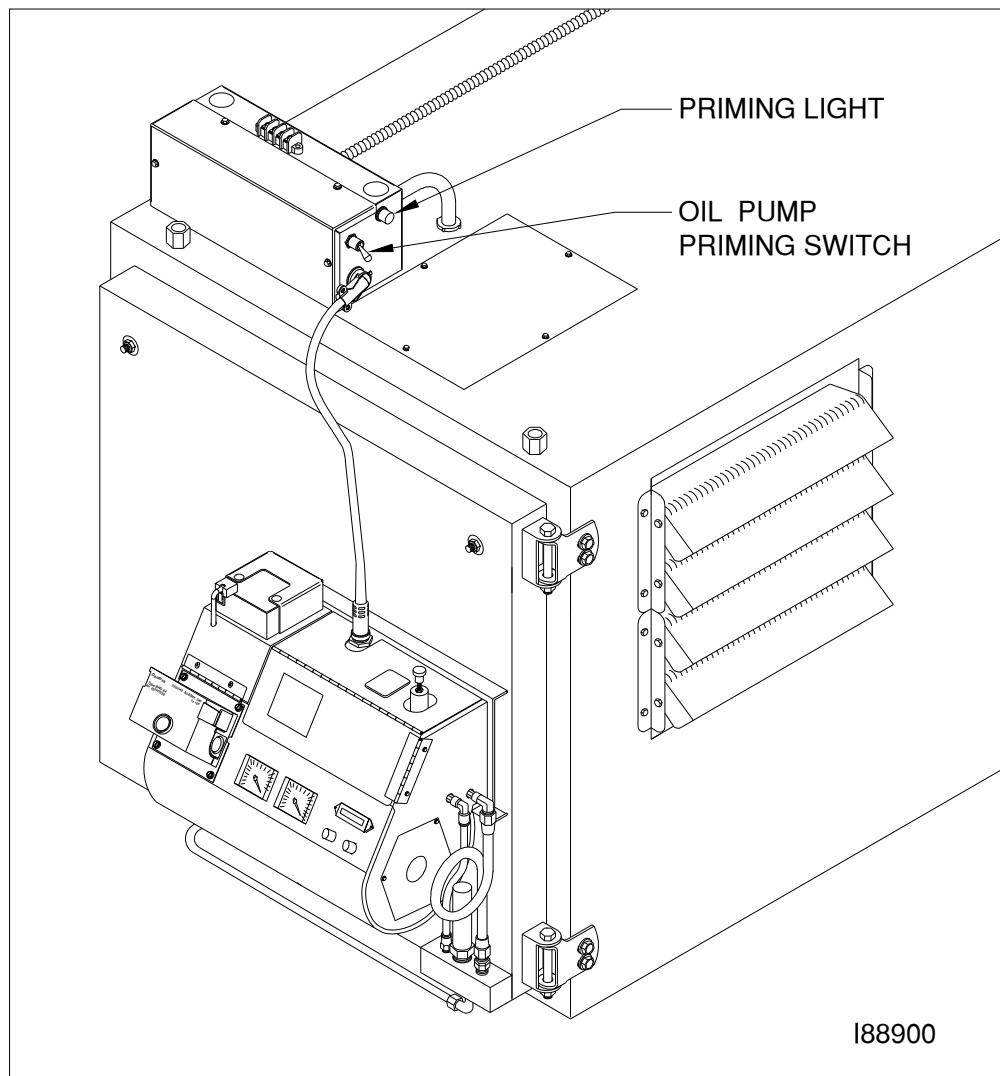

Figure 5B - Locating the Oil Pump Priming Switch

Priming the Metering Pump (continued)

9. Run the pump until a solid stream of oil flows from the pump bleeder. This will bleed all air out of the suction line, oil filter and pump head.
ATTENTION: For the metering pump to operate correctly, it is very important that the system is entirely full of oil and all air is bled out. The burner will shut down if there is any air in the system.
 10. Open the mini ball valve at the outlet port of the pump head to allow the pressure oil line to be filled.
 11. Close and tighten the bleeder on the pump.
 12. Turn the priming switch to the burner position so that the pump stops running.
 13. Disconnect the pressure oil line from the burner and position a container to catch oil which will flow from the pressure oil line during pump priming.
 14. Turn the priming switch to the prime position. The pump should start running immediately.
 15. Run the oil pump until the proper flow of oil has been established, and the oil line has been completely flushed out.
 16. Turn the priming switch to the burner position so that the pump stops running.
 17. Re-connect the oil line to the burner.
-

Vacuum Testing the Oil Pump

Vacuum testing the oil pump is a very accurate way to determine the following:

- The condition of the pump -- the ability of the pump to pull a vacuum and suck oil from the tank.
- The condition of the fittings, gaskets and seals from the ball valve to the pump -- these components must all be airtight to avoid suction leaks.

The following procedure provides instructions for vacuum testing the pump and canister filter on systems equipped with a ball valve.

ATTENTION: For the pump to pull and hold vacuum, it is critical that all fittings are airtight. If any of these fittings are loose, the pump may not pull a vacuum or may lose the vacuum rapidly. It is also critical that all fittings in the suction line, including fittings on the canister filter, are 100% airtight.

1. Follow the instructions to prime the pump (previous procedure).
NOTE: The pump will not pull a vacuum if the pump is dry. There must be oil in the gears of the pump before the pump can pull a vacuum.
2. With the pump running, open the bleeder two to three full turns, and make sure that oil is flowing from the bleeder. **DO NOT** close the bleeder yet.
3. Refer to Figure 5A. Close the ball valve at the inlet to the canister filter. Observe the vacuum gauge.
NOTE: The ball valve must have a stainless steel ball and should be pressure tested by the manufacturer to ensure that it does not leak. If the ball valve leaks, the vacuum test will not be accurate.
4. The vacuum should increase within 30 seconds to 15 inches of vacuum. When the vacuum gauge reads 15 inches of vacuum, first close and tighten the bleeder, then turn the pump off and close the mini ball valve at the outlet port of the pump. Observe the vacuum gauge.
NOTE: If the pump will not pull at least 15 inches of vacuum, there is a very serious suction leak, or the pump is damaged.

Vacuum Testing the Oil Pump (continued)

5. If there are no suction leaks, the system will hold vacuum.
NOTE: It is acceptable for the vacuum to drop one to five inches within one minute as the seal in the pump seats. The vacuum should then hold steady for 15 minutes.

ATTENTION: If the vacuum drops *more than one to five inches within the first minute*, there is one or more leaks somewhere between the pump and the ball valve. Do the following:

- Wipe your finger along the cylinder at the shaft of the pump. If there is oil here, the pump seal is damaged. Replace the pump.
 - Disassemble and clean all the fittings from the pump to the ball valve. Properly seal all fittings with Permatex #2 non-hardening gasket sealer or equivalent. Check the condition of the o-ring on the canister filter and tighten the four canister filter bolts in a crisscross pattern.
 - Repeat the procedure to vacuum test the system to ensure that the system is air tight.
6. Follow the instructions to prime the metering pump after a vacuum test has been performed.

SECTION 6: STARTING AND ADJUSTING THE BURNER

Understanding Burner Startup and Adjustment

Starting and adjusting the burner involves a series of separate procedures which must be accomplished in sequence without interruption. Review all the procedures before attempting burner startup and adjustment, paying careful attention to safety information statements.

Preparing the Burner for Startup

1. Turn the switch on the wall thermostat OFF.
NOTE: If your thermostat does not have an OFF setting, disconnect one thermostat wire so the burner will not run.
2. Turn the main power to the furnace ON.
3. Wait at least 15 minutes until the preheater block is thoroughly warmed up. (Feel the back of the burner box to make sure the preheater is sufficiently warm. The proving switch on the preheater block will not allow the burner to start until the block is hot.)
NOTE: The preheater block will remain warm as long as power is supplied to the burner. If the main power supply is ever turned OFF, you must wait at least 15 minutes until the preheater block is thoroughly warm before starting the burner.
4. Refer to Figure 6A to locate the air regulator. Loosen the locking nut on the air regulator.
5. Turn the adjustment knob on the air regulator counterclockwise until 12mm (1/2") of the threads on the knob are exposed. **DO NOT** back the knob all the way out.

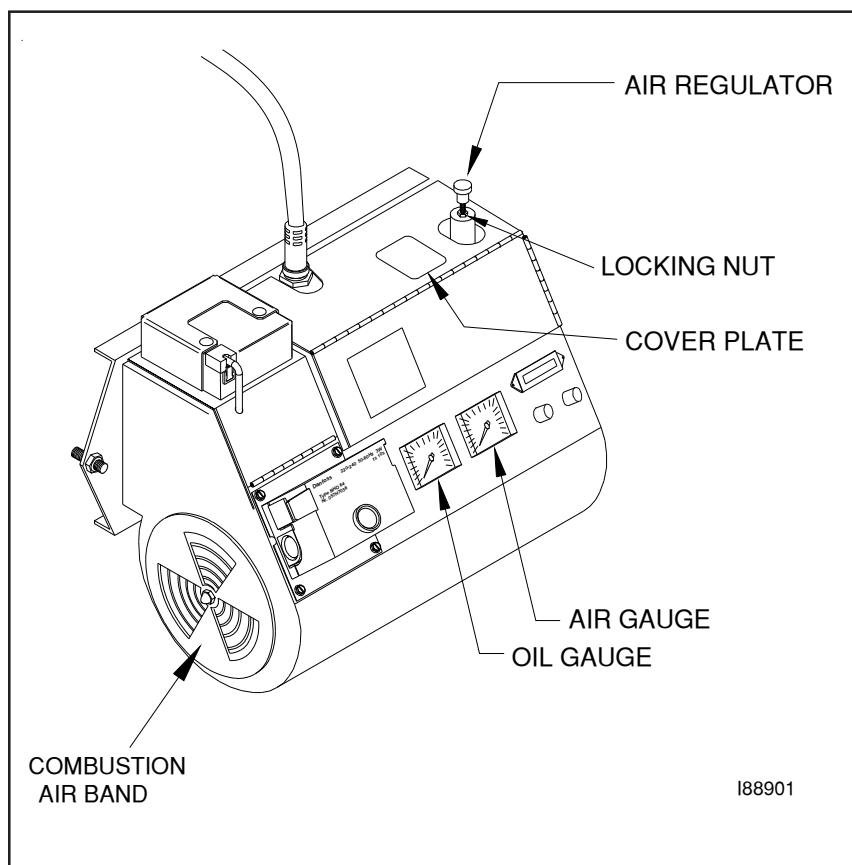

Figure 6A - Component Detail of the CB-500 Burner

Preparing the Burner for Startup (continued)

NOTE: The air gauge will not show any pressure until the burner starts. Before starting the burner for the first time, it is very important to turn the air regulator completely OFF as described.

6. Initial Adjustment of the Combustion Air Band:



WARNING: The combustion air band must be properly adjusted to ensure that the burner ignites and burns correctly. DO NOT attempt to start the burner with the combustion air band wide open or completely closed. The burner may not ignite correctly. Failure to heed this warning may result in a fire or explosion hazard.

- Refer to Figure 6A to locate the combustion air band.
- Rotate the combustion air band to adjust it to the appropriate initial slot opening as listed in the following **Initial Adjustment Charts**. Use a ruler to accurately set the slot opening at the widest section of the slot.

IMPORTANT NOTE: This initial setting of the combustion air band will allow you to start the burner. You will fine tune the combustion air band further as described later in these instructions.

ATTENTION: The settings shown in the charts below are only *initial* adjustments. **Final adjustments must be done by inspecting the flame length according to the illustrations provided on the following page.**

NOTE: The oil pressure is automatically adjusted by the metering pump. The approximate oil pressure range during initial startup is 0.07 to 0.28 bar (1 to 4 psi) for Model CB-1500, and 0.28 to 0.55 bar (4 to 8 psi) for Model CB-2500.

Initial Adjustments for CB-1500

Maximum Input = 44 Kw @ 4.0 LPH (150,000 BTUH @ 1.1 GPH) with CB 500 Burner

Oil Type	Oil Pressure/Flame Length	Air Bar (PSI)	Air Band	Nozzle
#2 Fuel Oil*	<i>check flame length</i>	0.8-1.1 (12-16)	5 mm (3/16")	9-5
Used Crankcase Oil	<i>check flame length</i>	0.8-1.1 (12-16)	5 mm (3/16")	9-5
Used ATF	<i>check flame length</i>	0.8-1.1 (12-16)	10 mm (3/8")	9-5
Used Hydraulic Oil	<i>check flame length</i>	0.8-1.1 (12-16)	10 mm (3/8")	9-5
#4 and #5 Fuel Oils	<i>check flame length</i>	0.8-1.1 (12-16)	10 mm (3/8")	9-5

Initial Adjustments for CB-2500

Maximum Input = 73 Kw @ 6.4 LPH (250,000 BTUH @ 1.7 GPH) with CB 500 Burner

Oil Type	Oil Pressure/Flame Length	Air Bar (PSI)	Air Band	Nozzle
#2 Fuel Oil*	<i>check flame length</i>	0.8-1.1 (12-16)	22 mm (7/8")	9-5
Used Crankcase Oil	<i>check flame length</i>	0.8-1.1 (12-16)	22 mm (7/8")	9-5
Used ATF	<i>check flame length</i>	0.8-1.1 (12-16)	25 mm (1")	9-5
Used Hydraulic Oil	<i>check flame length</i>	0.8-1.1 (12-16)	25 mm (1")	9-5
#4 and #5 Fuel Oils	<i>check flame length</i>	0.8-1.1 (12-16)	25 mm (1")	9-5

*If you are burning light viscosity oils such as #2 fuel oil, it may be necessary to install a smaller nozzle. Call your Clean Burn dealer for more information.

Starting the Burner

- Turn the switch on the wall thermostat to HEAT and adjust the thermostat setting above room temperature to start the burner.
NOTE: If the burner refuses to start, review the *Preparing the Burner for Startup* procedure. If, after repeating this procedure, the burner still refuses to start, check the following system components for proper functioning:
 - Verify that the red wire as shown in the **Burner Wiring Diagram** (Appendix B) is energized to 230VAC.
- Adjusting the Air Regulator:**
 As soon as the burner starts running, turn the knob on the air regulator clockwise to achieve proper operating air pressure. Refer to the **Initial Adjustment Charts**.
NOTE: If the safety reset on the primary control is activated and the burner stops running, see Section 7 for further instructions on restarting your burner.
- Observing the Flame Length:**
 Visually inspect the flame length through the observation port. Refer to Figure 6B for an illustration of the desired flame length. The flame should extend no more than one-half of the way down the combustion chamber.



WARNING: The observation port gets hot as the burner fires. To avoid personal injury, always wear heavy work gloves and safety glasses when opening the port and viewing the flame.

CAUTION
WHEN OPENING INSPECTION PORT

**PORT MAY BE HOT
PROTECT HANDS
WEAR SAFETY GOGGLES
KEEP FACE AWAY
OPEN PORT SLOWLY**

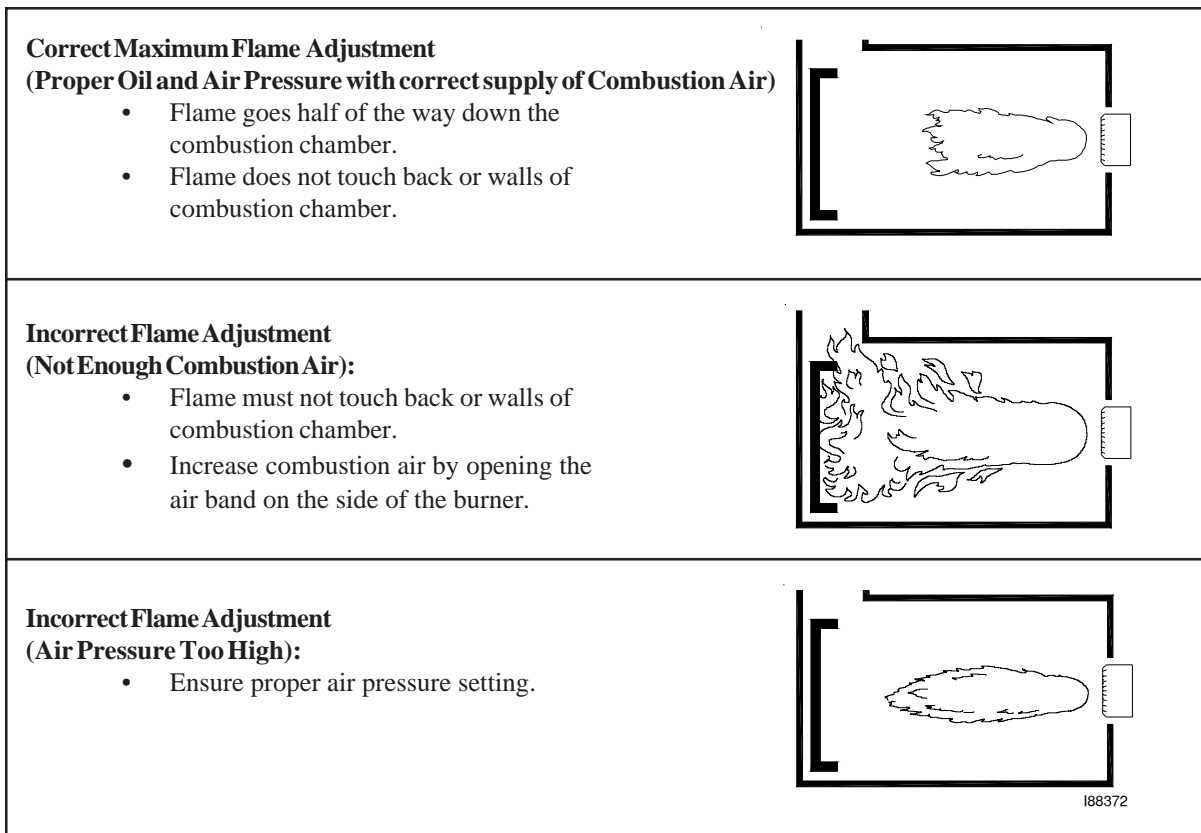

Figure 6B - Flame Length Adjustment

Starting the Burner (continued)

4. Check the flame length after the burner has fired for 15 minutes.
5. Tighten the locking nut on the air regulator.

6. **Fine Tuning the Combustion Air Band:**

NOTE: The initial setting of the combustion air band may require additional adjustment.

- Refer to Figure 6A to identify the combustion air band location on the burner.
- Observe the flame. The flame should be yellow-white with sharp tips and no "sparkles."
- If the flame is orange in color or the flame length is too long, the oil you are burning requires MORE combustion air. OPEN the air band 3mm to 6mm (1/8" to 1/4"), and re-check the flame for the proper characteristics.
- Re-check the flame after five minutes. You should see a yellow-white flame with sharp tips and no "sparkles", and the flame should extend half of the way down the combustion chamber.

7. **Checking for a Smokeless Burn:**

Check for a smokeless burn by observing the stack while the burner is running. If you see any smoke, repeat the previous steps for setting the combustion air band and adjusting the air regulator. After adjusting the combustion air band, re-check the flame length.

NOTE: Check for a smokeless burn periodically (as you do the flame length). Immediately readjust the burner if you ever see smoke coming from the stack. Smoke indicates improper air/fuel adjustment.

NOTE: When using instruments to adjust the burner for a smokeless burn, the following readings should be achieved:

- Draft over fire should be -.02 inch w.c.
- Adjust for a smoke spot of a trace to 2
- Adjust for a CO₂ reading of 8 to 10% or an O₂ reading of 7 to 9%
- Cad cell reading below 500 ohms

Checking the Operation of the Blower Motor

NOTE: It is important to verify that the blower motor operates correctly to ensure that the fan switch is properly cycling the blower motor as described below. Also refer to Appendix A at the back of the manual for additional pertinent information.

1. Start the burner and adjust it as described previously in this section.
2. The blower motor will not start until the burner has been running for 5 to 15 minutes to heat up the combustion chamber and heat exchanger. At this point, the fan switch will activate the blower motor.
3. Once the blower motor has activated, turn the burner off by turning the wall thermostat to OFF.
4. With the burner off, the blower motor should continue to run for 5 to 10 minutes until the combustion chamber is cooled down. The fan switch will then shut off the motor.



WARNING: If the blower motor does not operate as described, immediately shut down your furnace to avoid potential equipment damage and/or fire hazard. Contact your Clean Burn dealer immediately.

SECTION 7: RESETTING THE FURNACE AND BURNER

Understanding Furnace/Burner Shutdowns

When troubleshooting furnace/burner shutdown situations, Clean Burn recommends the following sequence of actions:

- Follow the procedure for Resetting the Oil Primary Control provided in this section.
- Review the material on the following page about the safety switches to determine if the furnace is shut down on high limit.
- If the burner still will not restart, contact your Clean Burn Distributor for immediate service.

Understanding the Oil Primary Control

The oil primary control will shut the oil pump and oil solenoid off when it detects flame-out during burner operation. The oil primary control will then wait approximately 15 seconds (while the burner motor, air solenoid, and transformer are energized) and attempt to re-ignite the burner (recycle mode). If the burner does not re-ignite, the control will shut the burner off on safety lock-out. The following procedure explains what should be done when this occurs. *It is very important that you follow these instructions precisely when resetting the safety on the primary control and restarting the burner.*

Resetting the Oil Primary Control



DANGER! DO NOT reset the oil primary control if oil mist is present in the combustion chamber or when the combustion chamber is hot! DO NOT operate your furnace if excess oil, oil vapor or fumes have accumulated in or near the unit. As with any oil burning appliance, improper operation may result in a fire or explosion hazard.

1. Refer to Figure 7A.
2. Allow 5 to 10 minutes for all fuel mist to exhaust from the combustion chamber.
3. If the combustion chamber is hot, allow the furnace to cool for at least 30 minutes. DO NOT push the reset button.
4. When you are sure that all fuel mist has cleared and the furnace has cooled, push in and hold the reset button for three seconds, then release. This will reset the control at any time during its operation.
5. If the burner will not restart, call your Clean Burn dealer immediately.

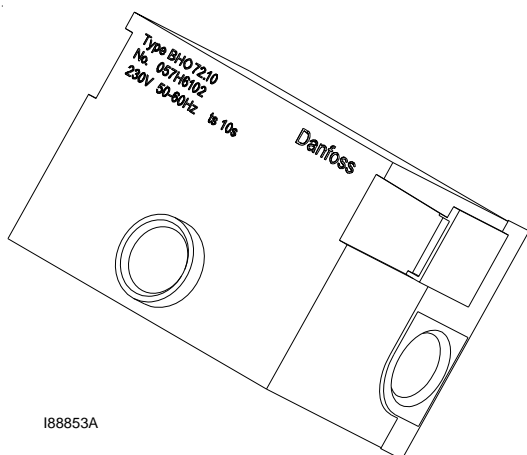

Figure 7A - Danfoss Oil Primary Control

The Blower/Fan Switch

The CB-1500/CB-2500 furnaces feature an F-180 blower/fan switch (normally open) which is surface mounted at the front of the combustion chamber (see Figure 7B). The blower/fan switch senses the temperature of the combustion chamber as the burner is firing. When the combustion chamber reaches the proper temperature, the blower/fan switch closes and sends power to the blower motor to turn ON the blower. When the wall thermostat is satisfied and the burner shuts off, the blower continues to run until the switch senses that the combustion chamber has cooled down. The switch then opens and shuts off the blower.

The Hi-Temp Limit Switches

The CB-1500/CB-2500 furnaces also feature two high temperature limit switches which are mounted on a bracket at the front of the combustion chamber as shown in Figure 7B. The switches sense the build up of heat within the combustion chamber and are designed to protect the furnace from damage due to overheating. The limit switches are wired in series and are both auto-resetting.

Understanding the Function of the L-200 Hi-Temp Limit Switch

If the temperature of the combustion chamber is too hot, the L-200 hi-temp limit switch opens and shuts off power to the primary control on the burner, and the burner shuts off. The blower continues to run to cool down the furnace. After the combustion chamber has cooled down, the L-200 hi-temp limit switch will automatically reset and allow the burner to restart.

ATTENTION: *If the L-200 hi-temp limit switch is opening repeatedly, the burner MUST be readjusted according to the instructions in Section 6 to correct the overheating problem, or serious damage to the furnace may occur.*

The L-200 hi-temp limit switch will open and shut down the burner if any of the following conditions exists:

- **The furnace is over firing.** Review the directions in Section 6 to properly adjust the burner.
- **Improper ductwork is installed on the furnace (*applicable only if your furnace is operating as a central furnace*).** Ductwork must be installed by qualified HVAC personnel according to industry standards and the specifications provided in Section 3.

Understanding the Function of the L-290 Auxiliary Auto-Reset Hi-Temp Limit Switch

The L-290 auxiliary auto-reset high temperature limit switch is a back-up safety switch for the L-200 hi-temp limit switch.

Both the L-200 and L-290 auxiliary hi-temp limit switches will open and shut down the burner if:

- **the blower has stopped running for any reason during furnace operation,** the heat in the furnace will cause the limit switches to open. Ensure that the blower is functioning properly.

ATTENTION: *It is very important to determine the reason for the opening of the limit switches and take steps to correct the cause; failure to do so may result in serious overheating and damage to the heat exchanger of the furnace. Additionally, if the burner is rapidly cycling on/off, contact your Clean Burn Distributor immediately; failure to address this situation may result in serious damage to the furnace.*

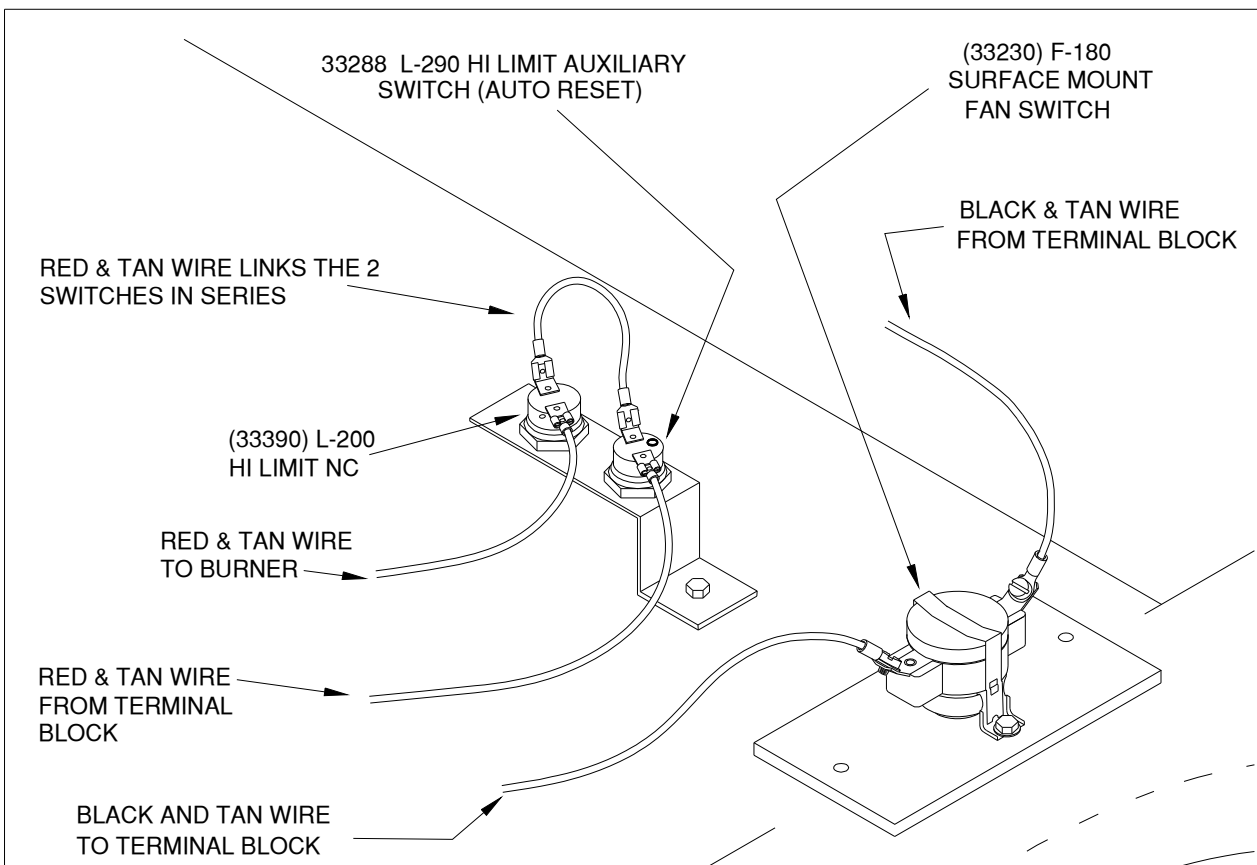
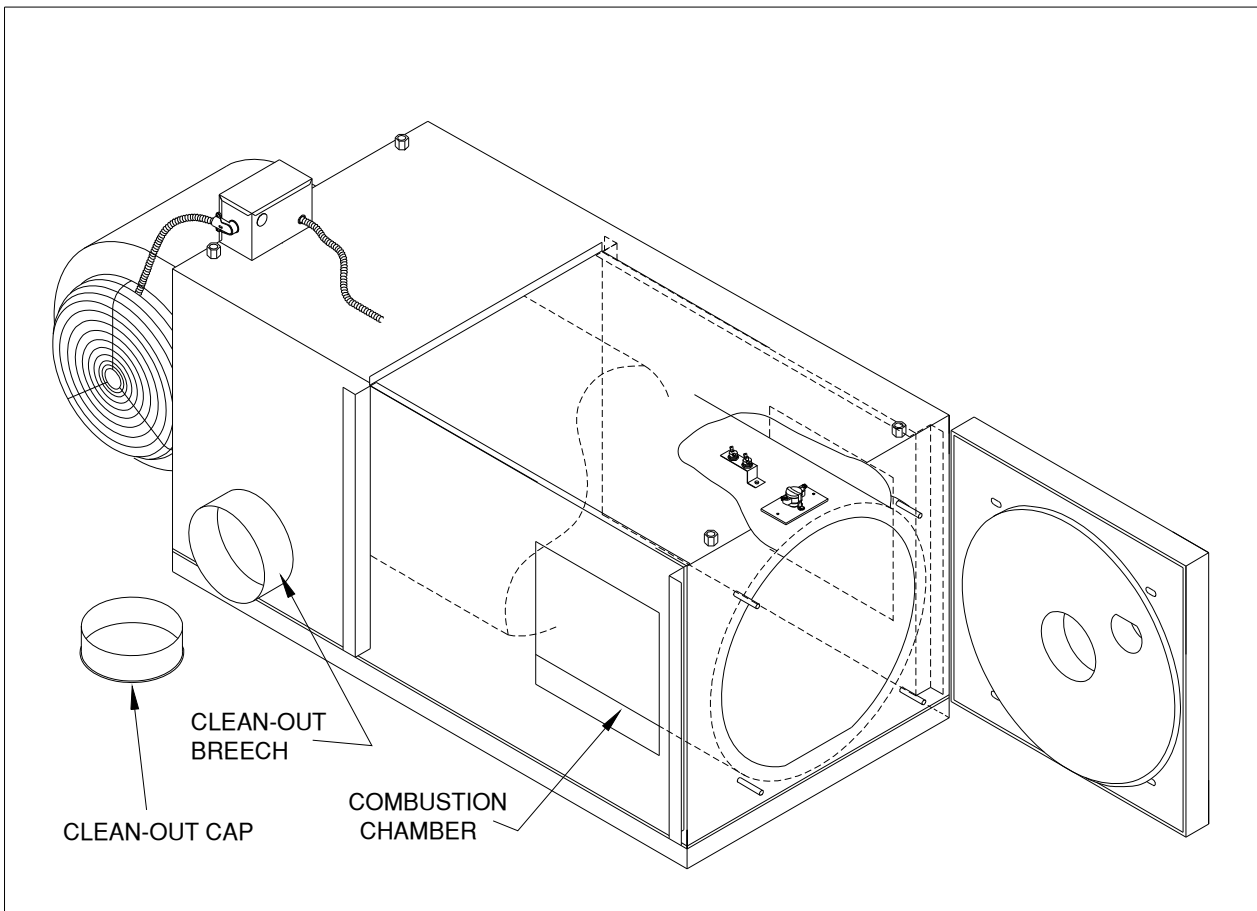

Figure 7B - Locating the Fan Switch and Hi-Temp Limit Switches

188947

SECTION 8: ADJUSTING THE DRAFT OVERFIRE

Understanding the Importance of Draft

Draft in the furnace is created as the hot combustion gases rise up the stack, creating a negative pressure inside the stack and the furnace. This negative pressure is measured as inches of water column (W.C.) of draft. A proper draft overfire of $-.02$ to $-.04$ w.c. is essential so that all combustion products travel away from the burner, down the combustion chamber, through the furnace flues and up the stack.

Checking for Correct Draft Overfire



WARNING: Correct draft overfire is *essential* for the proper and safe operation of your furnace.

Your furnace is equipped with an observation/draft reading port to check draft overfire. A *qualified serviceman with proper equipment must check/adjust your furnace for proper draft.* Contact your Clean Burn dealer for this service.

1. Insert the probe of the draft gauge instrument into the draft reading port in the observation port as shown in Figure 8A.
NOTE: Follow the directions with the draft gauge to use your specific type of gauge.
2. Note the draft overfire reading on the draft gauge.

ATTENTION: The draft reading should be in the $-.02$ to $-.04$ w.c. range. Poor draft (i.e. $-.01$ to $+.08$) results in back pressure in the furnace and poor burner performance. Too much draft overfire (i.e. *greater than* $-.04$) sucks the heat from the furnace and results in abnormally high stack temperature.

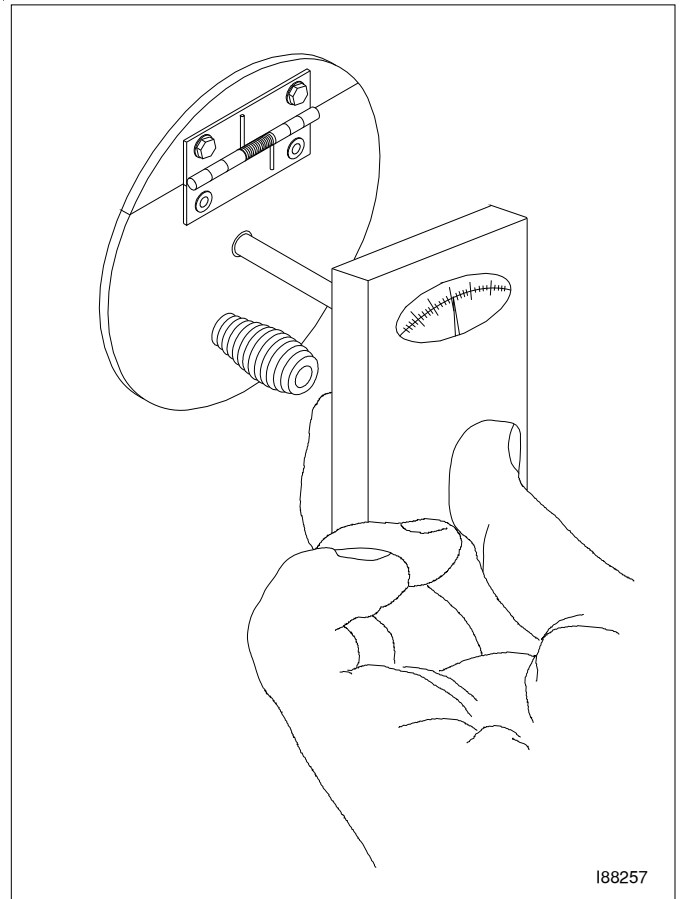

Figure 8A - Checking for Proper Draft Overfire

Adjusting the Barometric Damper

NOTE: If the draft overfire is not in the $-.02$ to $-.04$ w.c. range, it is necessary to adjust the barometric damper.

1. Before starting the burner, turn the weight on the flapper **COUNTERCLOCKWISE** until the flapper remains closed. This will provide maximum draft for the furnace.
2. Follow the directions in Section 6 to start and adjust the burner.
3. With the burner running, check the draft overfire with a draft gauge.
4. As shown in Figure 8B, adjust the weight on the flapper to obtain a consistent $-.02$ w.c. draft overfire. Turn the weight **COUNTERCLOCKWISE** to increase draft (i.e. draft increases as the flapper closes). Turn the weight **CLOCKWISE** to decrease draft (i.e. draft decreases as the flapper opens).
5. Tighten the locking nut to securely hold the weight in position.

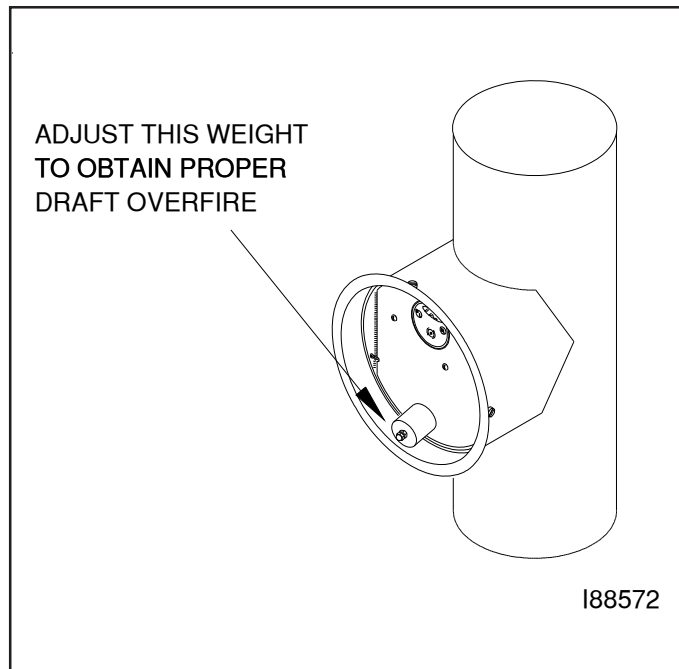

Figure 8B - Adjustment of Barometric Damper

Solving Draft Overfire Problems



WARNING! If you cannot achieve proper draft overfire, do not operate your furnace!
Contact your Clean Burn dealer for assistance.

ATTENTION: Backdraft must be resolved or your furnace will not operate correctly!

Under backdraft conditions, draft overfire readings will show positive pressure in the combustion chamber. *Backdraft means that oil spray, combustion products, and heat are blown back against the burner. Backdraft results in oil-fouled retention heads and electrodes. Severe backdraft will force heat back against the burner and result in heat damage to the cad cell and transformer.*

Backdraft is caused by the following conditions:

- Poor draft caused by improper stack design. (See Section 4.)
- Poor draft caused by improper adjustment of the barometric damper. (See Above)
- Incorrect combustion air band setting on the burner. (See Section 6.)
- Furnace flues are plugged with ash. (See Section 9.)
- Exhaust fans in your building are sucking gases down the stack.

Understanding the Effect of Exhaust Fans on Draft

Any type of exhaust fan, paint booth, or exhaust system in a building will create negative pressure in the building unless there is a source of make-up air (i.e. fresh air which enters the building and replaces the air removed by the exhaust fans.) Refer to Figure 8C on the following page.

If there is insufficient make-up air, the exhaust fan will suck air and combustion gases down the furnace stack and create backdraft in the furnace. Even if the exhaust fan is on another level of the building or in another room away from the furnace, the exhaust fan will still create backdraft at the furnace.

Checking Draft Overfire to Determine Severity of Backdraft

The following procedure is an accurate method of determining how much backdraft is created by the exhaust fans. Once this is determined, you can select the correct method for resolving the backdraft. Refer to Figure 8C on the following page as needed.

1. Turn off ALL exhaust fans and close ALL doors and windows in the building (any open door or window will allow make-up air to enter the building and will negate the test).
2. Start the furnace and adjust the barometric damper so that the draft overfire is $-.02$ w.c.
3. Check the draft overfire again. Now have someone start the exhaust fans.
4. Note how much the draft overfire has changed.

ATTENTION: If the draft overfire changed towards positive, it is mandatory that make-up air is provided to the building or severe damage to the furnace and burner will occur. If the draft overfire remained constant at $-.02$ w.c., there is sufficient make-up air entering the building, and the exhaust fan is not adversely affecting the draft.

Special Note to Service Personnel

To arrive at proper draft measurements be sure that all fans within the building are running while adjusting the draft to final levels!

DRAFT OVERFIRE OF $-.02$ TO $-.04$ W.C. MEANS COMBUSTION GASES ARE FLOWING AWAY FROM THE BURNER, THROUGH THE FURNACE FLUES AND UP THE STACK

SERVICEMAN ADJUST BAROMETRIC DAMPER TO OBTAIN $-.04$ TO $-.06$ W.C. DRAFT AT STACK

Corresponding Draft Over Fire measurement should be $-.02$ to $-.04$ WC

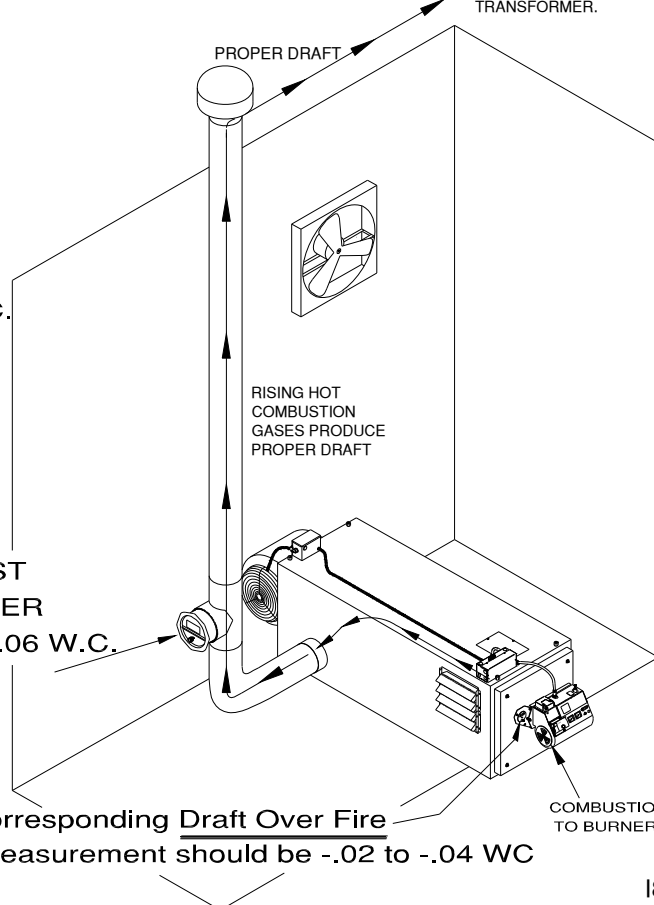
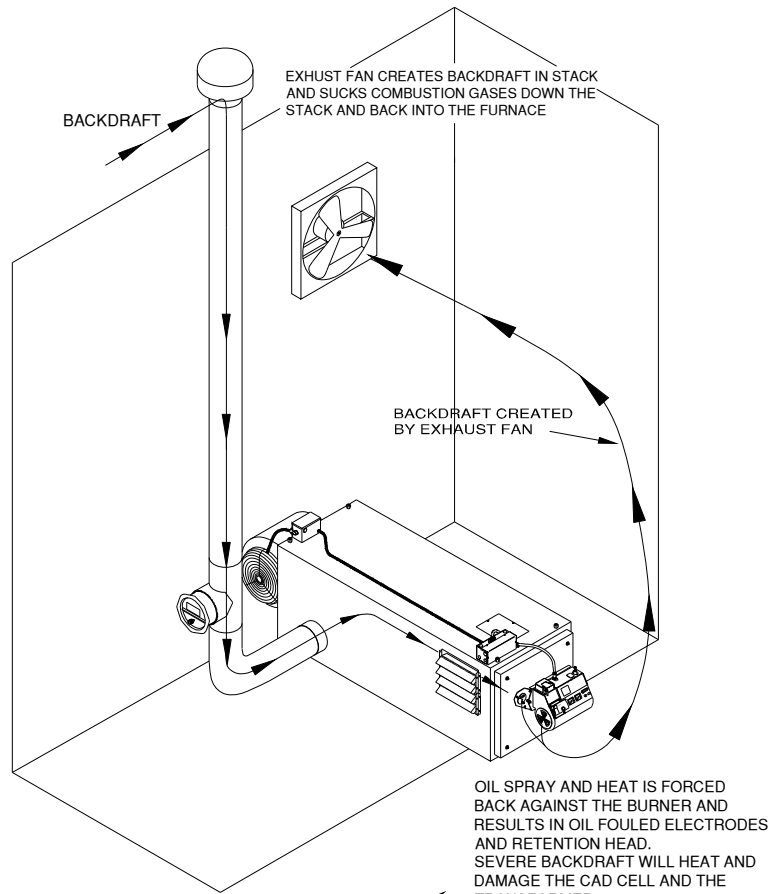

188948

Figure 8C - Proper Draft vs. Backdraft

Installing a Make-up Air Louver

Exhaust Fans and Make-up Air Louvers

When exhaust fans are operated in tight buildings, there is little or no source of fresh air to replace the air removed from the building by the exhaust fan. This results in negative pressure (vacuum) in the building which creates severe backdraft problems at the furnace.

Properly sized make-up air louvers are designed to allow adequate fresh air to enter the building during operation of the exhaust fans. The louvers automatically open under the vacuum created by the exhaust fans. The louvers open just enough to provide the correct amount of fresh air. The louvers automatically close when the exhaust fans are turned off.

Sizing the Make-up Air Louver

IMPORTANT NOTE: When using louvers and grills, and the actual free area of the louver or grill is not known, it is understood that wooden louvers/grills will have a free area of 25%, while metal louvers/grills will have a free area of 75%. ("Free area" translates into the actual space allowing air to flow through.)

- Procedure 1:**
- (a) Determine the volumetric flow rate of the exhaust fan. This information should be stamped on a label on the exhaust fan. Make sure to add up the total volumetric flow rate if more than one exhaust fan exists in the building.
 - (b) Select the correct size of make-up air louver to provide the required fresh air.

If you cannot determine the volumetric flow rate of the exhaust fan, use the following procedure.

- Procedure 2:**
- (a) Count the total number of exhaust fans in the building.
 - (b) Close all of the doors and windows in the building *except* for one overhead garage door.
 - (c) Start the furnace and allow it to run for 15 minutes to bring it up to temperature.
 - (d) Set the draft-over-fire for $-.02''$ to $-.04''$ W.C.
 - (e) Turn ON all of the exhaust fans in the building.
 - (f) Now close the opened overhead garage door *slowly*, just until the draft gauge moves down into a positive (+) draft reading; as soon as it reaches this point, STOP the door at that position.
 - (g) Slowly open the door back up, just until the draft reading comes back up to the $-.02''$ to $-.04$ W.C.
 - (h) Measure the size of the door opening.

Example of Calculations for Sizing Make-up Air Louver

Measured door opening: 366 cm (144") wide x 30 cm (12") high

- Convert to cm^2 (ft^2) - in this case it equals $10,980 \text{ cm}^2$ (1728 in^2)
- Multiply by 1.1 correction factor: $10,980 \text{ cm}^2 \times 1.1 = 12,078 \text{ cm}^2$
($1728 \text{ in}^2 \times 1.1 = 1901 \text{ in}^2$)
- Multiply by free area factor: $12,078 \text{ cm}^2 \times 1.25 = 15,098 \text{ cm}^2$
($1901 \text{ in}^2 \times 1.25 = 2367 \text{ in}^2$)
- Refer to sizing chart on the following page - required grill size would be:
(1) 137cm x 137cm (54in. x 54in.) grill

Installing a Make-up Air Louver (continued)

CALCULATED OPENING SIZE		REQUIRED LOUVER / GRILL SIZE	
cm ²	in ²	cm	in
0 – 528	0 – 82	25 x 25	10 x 10
529 – 836	83 – 130	30 x 30	12 x 12
837 – 1,445	131 – 224	41 x 41	16 x 16
1,446 – 1,923	225 – 299	46 x 46	18 x 18
1,924 – 2,390	300 – 370	51 x 51	20 x 20
2,391 – 3,166	371 – 490	61 x 61	24 x 24
3,167 – 4,769	491 – 739	76 x 76	30 x 30
4,770 – 7,150	740 – 1109	91 x 91	36 x 36
7,151 – 9,182	1,110 – 1,424	107 x 107	42 x 42
9,183 – 12,355	1,425 – 1,915	122 x 122	48 x 48
12,356 – 15,499	1,916 – 2,400	137 x 137	54 x 54
15,500 – 19,650	2,401 – 3,045	152 x 152	60 x 60

Installing the Make-up Air Louver

All louvers and grills, regardless of the material from which they are made, must be FIXED in the OPEN position OR be interlocked with the appliance so that they will open automatically during the operation of the appliance. The interlock must be placed on the driven member.

NOTE: It is very important to follow these instructions carefully to ensure proper performance of the louver.

1. The louver must not be close to the furnace. The fresh air should travel at least 10-13m (40-50 feet) before reaching the furnace so the air warms up. The furnace will not heat well if it is receiving cold return air.
2. The louver must be high in the sidewall of the building so the cold fresh air does not blow across the floor level and chill the service personnel.
3. The louver should be installed in the opposite wall from the location of the exhaust fan. This will quickly vent diesel exhaust from the top of the building and reduce the amount of run time for the exhaust fan.

SECTION 9: MAINTENANCE

Understanding Maintenance

Servicing your Clean Burn furnace in a timely manner is very important to keep your furnace running in peak condition. Just as an automobile requires periodic maintenance such as oil changes, engine tune-ups, etc. your Clean Burn furnace also requires regularly scheduled service.



WARNING: *Failure to maintain and/or improper servicing by unqualified personnel may adversely affect the proper, safe operation of your furnace and may reduce the service life of your furnace.*

The following chart summarizes all the service intervals which are required to maintain your furnace. Service instructions/procedures for these activities are included in this chapter.

Maintenance Activity	Interval
Periodic burner inspection	Monthly
Cleaning the canister filter	Before vacuum gauge reads 10" HG of vacuum
Servicing the metering pump	At least once a year
Cleaning out ash	Approx. 700 hours as indicated on the burner hour meter*
Cleaning the check valve/screen	At least once a year
Cleaning water/sludge out of tank	At least once a year
Annual burner tune-up	At least once a year

***It is very important to clean ash from the furnace on schedule.** Normal use of the furnace requires clean-out at least twice during the heating season. Heavy, around-the-clock usage requires more frequent clean-out. For instance, one month of continual running of the furnace is 720 hours (24 hours x 30 days = 720 hours).

NOTE: IMPORTANT! Record all maintenance activities in the Maintenance Record provided in the Appendixes.

Periodic Burner Inspection

Following initial start up of the burner, you should inspect the operation of the burner periodically--ideally on a monthly basis. Doing so ensures that the system is functioning efficiently and safely.

Follow these guidelines for inspecting the operation of the burner:

- Visually inspect the flame length through the observation port; the flame should extend no more than one-half of the way down the combustion chamber.
 - If the flame is diminishing or displays wide variations, clean the canister filter and check valve/screen (procedures provided in this section).
 - If the flame is firing too strongly (i.e. flame touches back and/or side walls of the combustion chamber), check the air pressure setting (see following guideline).
- Check the air pressure by observing the air gauge; proper air pressure settings are provided in Section 6. **DO NOT** overfire the burner; doing so on a continual basis will damage the furnace.
- Check the combustion air band setting for the proper opening and clean away any dust/debris as necessary. Note that the air band should **NEVER** be set fully open or closed.
- Check the draft over fire reading as specified in Section 8.

CAUTION

WHEN OPENING INSPECTION PORT

**PORT MAY BE HOT
PROTECT HANDS
WEAR SAFETY GOGGLES
KEEP FACE AWAY
OPEN PORT SLOWLY**

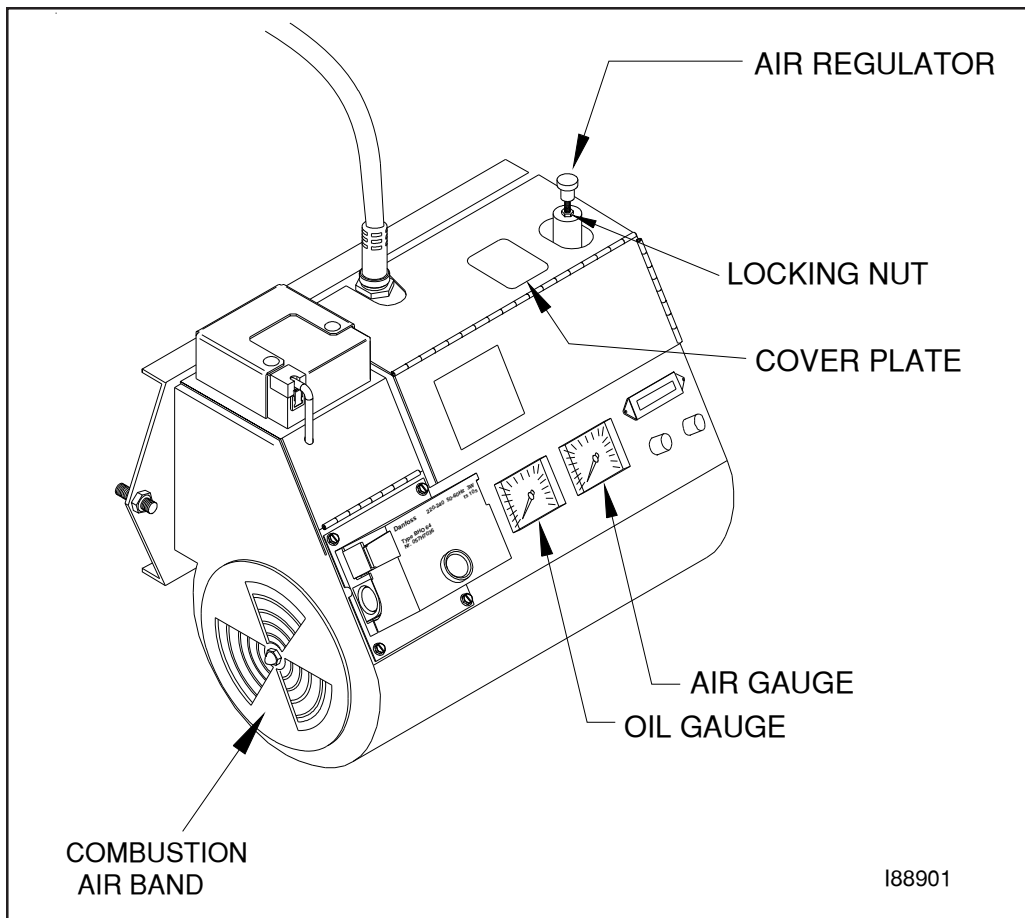

Figure 9A - Burner Component Detail

Cleaning the Canister Filter

ATTENTION: Never operate your furnace with more than 10" HG of vacuum on the suction side of the pump. High vacuum separates air from the oil and results in erratic burner operation.

The following protective gear should be worn when cleaning the filter:

- Rubber gloves
- Safety goggles

1. Close the ball valve adjacent to the filter.
2. Position a container under the filter.
3. Unscrew the four bolts to drain the oil from the canister.
4. Remove the canister bowl.
5. Clean the screen and the bowl in a parts washer.
6. Referring to Figure 9B, examine the filter components as you reassemble them.
7. Check the condition of the O-rings. Replace any that are cracked or worn.
8. Ensure that the canister filter is 100% airtight by firmly tightening the four bolts.
9. Open the ball valve. Refer to Sections 5 and 6 for instructions on priming the pump and starting the burner.

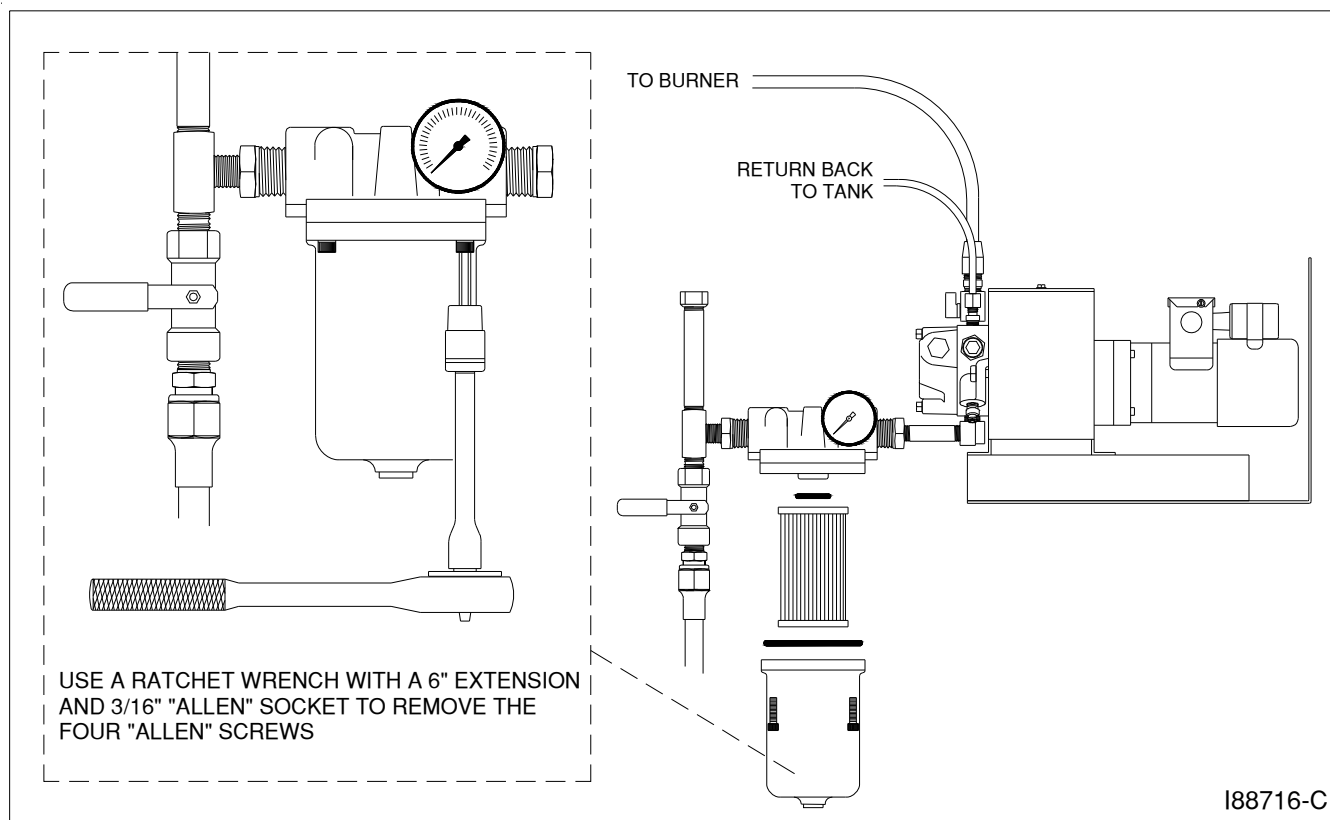

Figure 9B - Canister Filter Component Detail

Servicing the Metering Pump

1. Refer to Figure 9C.
2. Remove the pump head cover (part 1).
3. Remove the screen (part 2) and wash it.
4. Remove and discard the used gasket (part 3).
5. Install a new gasket (Clean Burn Part #32422).
6. Replace the screen and pump head cover.

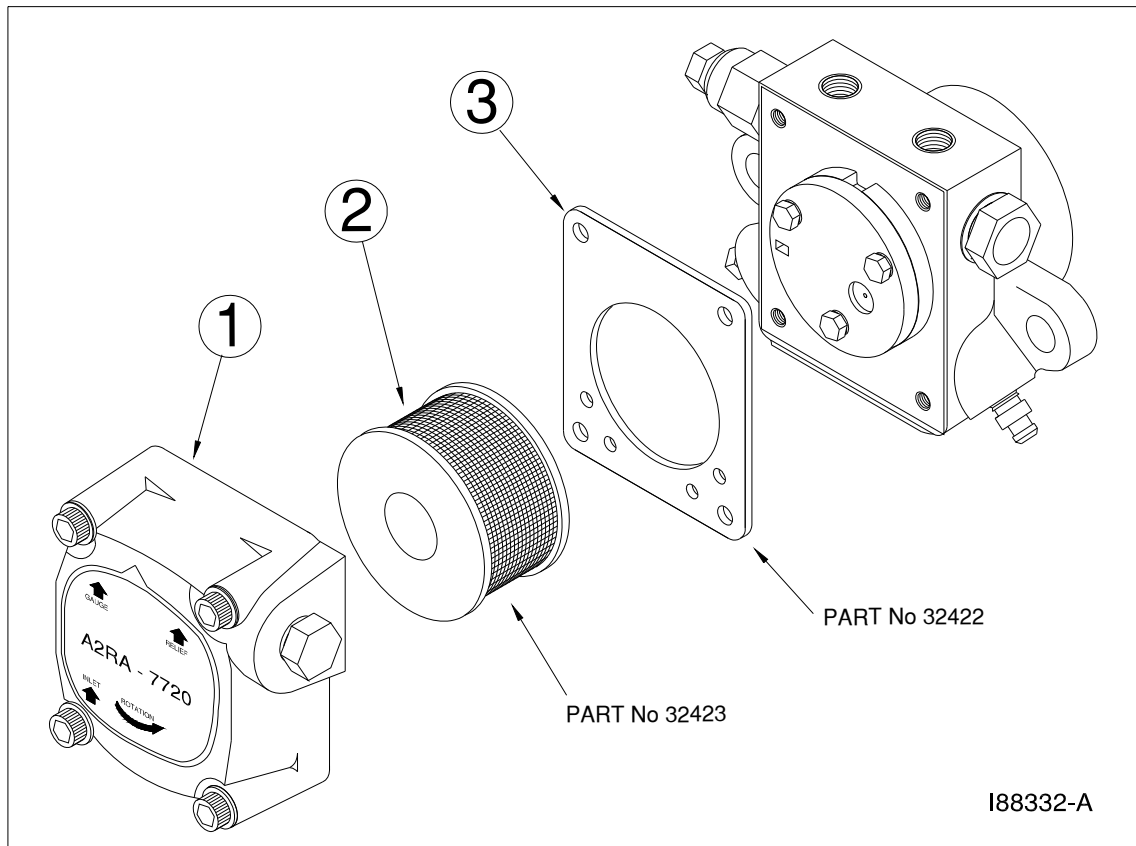

Figure 9C - Servicing the Metering Pump

Cleaning Ash From the Furnace

NOTE: The maintenance interval for cleaning ash from the furnace is approximately 700 hours of operation as indicated on the hour meter on the burner (refer to the servicing intervals at the beginning of this chapter). *Be sure to clean the ash from your furnace at least twice during the heating season. Your furnace may require more frequent clean out of the ash due to contaminants in the oil or heavy use.* As ash accumulates, furnace heat output declines, and the stack temperature rises. 3mm (1/8") of ash has the insulating capacity of 25mm (1") of fiberglass insulation and reduces heat transfer significantly. *Never allow more than 6mm (1/4") of ash to accumulate in the combustion chamber, heat exchanger flues, or stack.*



CAUTION: Be aware that used oils may contain heavy metallic compounds or foreign materials. When burned, these compounds are deposited within the furnace, necessitating *careful* cleaning. The following protective gear should be worn when cleaning the ash:

- Respirator for fine particles (a dust mask is not acceptable)
- Rubber gloves
- Safety goggles
- Protective clothing



CAUTION: Make sure you use a sturdy ladder or scaffolding for safe access to ceiling-hung furnaces. When cleaning the furnace, static electricity may build up in the shop vac hose. If this occurs, use #12 copper wire wrapped around the hose with the other end connected to the furnace (or other ground source) to eliminate the static.

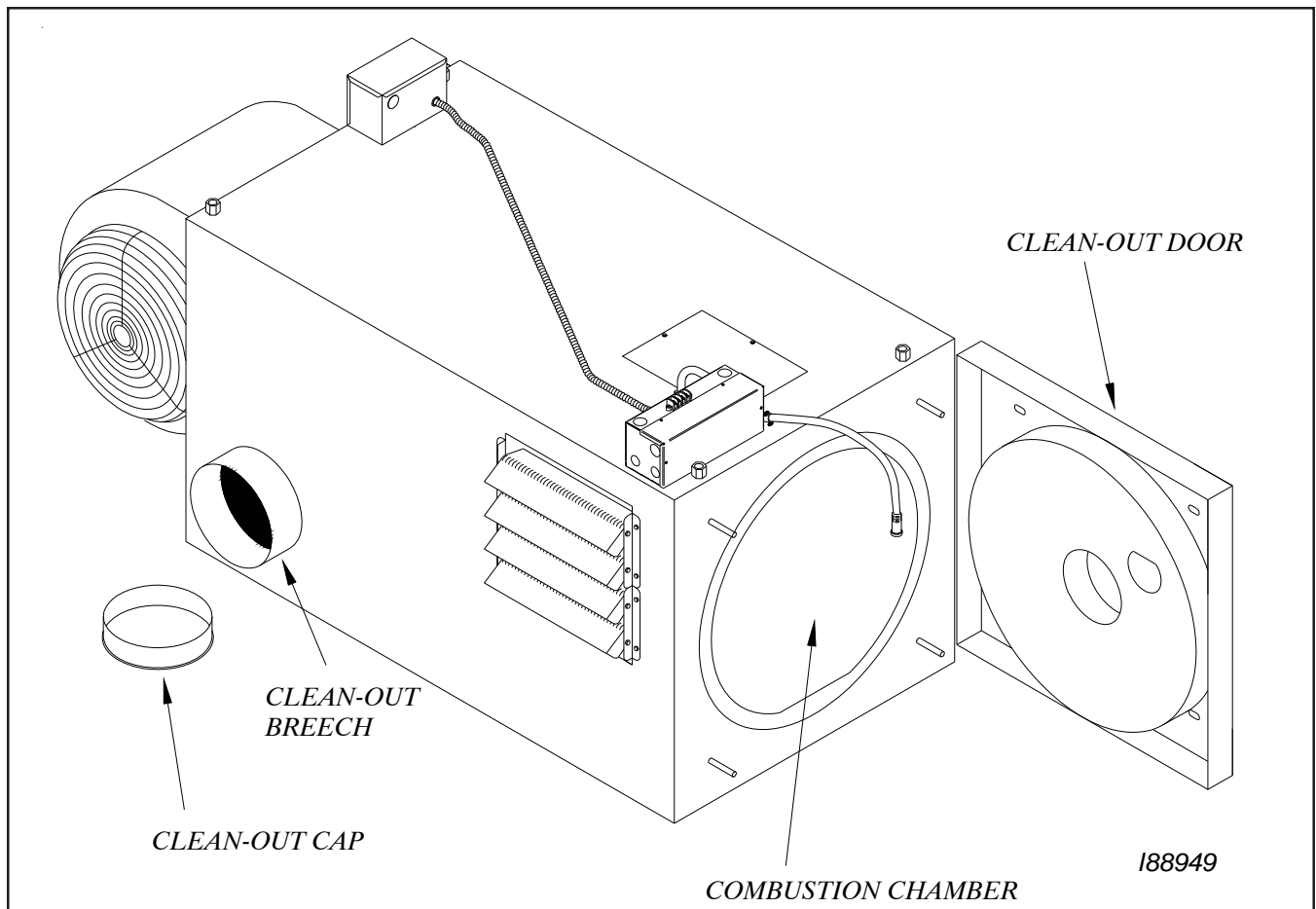

Figure 9D - Accessing the CB-1500 Combustion Chamber for Cleaning (CB-2500 is similar)

Cleaning Ash From the Furnace (continued)

1. Ensure that power has been turned OFF, and all "hot" components have been allowed to cool sufficiently. (*Allow at least one hour for the Energy Retention Disc to cool.*)
2. Clean the ash from the stack components:
 - a. Brush accumulated ash from the stack cap.
 - b. Lightly tap the stack components to loosen the ash.
 - c. Allow ash and dust to settle in the elbow on the stack.
NOTE: It is not necessary to remove the stack to clean it. You will vacuum ash from the stack elbow as you clean out the back of the furnace as described below.
 - d. Remove the clean-out cap from the unused furnace breach.
 - e. Thoroughly vacuum out the back of the furnace, including the stack elbow, through the clean-out breach. A long wand on the hose of your shop vac is helpful in reaching all the way through the back of the furnace to the stack elbow.
3. Clean the ash from the combustion chamber (see Figure 9D):
 - a. Bleed down pressure on the air and oil lines by slightly loosening the fittings at the bottom of the connector block.
NOTE: Turn off the shut-off on the air pressure line.
 - b. With air and oil pressure completely bled off, disconnect the air and oil pressure lines from the bottom of the connector block.
NOTE: Cover the lines to keep dirt from entering the air / oil supply.
 - c. Remove the lock-down nuts on the clean-out door.
 - d. Carefully swing open the clean-out door to expose the heat exchanger flues and the combustion chamber. Carefully remove the Energy Retention Disc with a long handle or pipe. Lightly vacuum the Energy Retention Disc.
 - e. Check the color of the ash--it should be light gray or tan.
ATTENTION: White ash indicates excessive air pressure. Black ash or soot indicates lack of combustion air. If these conditions exist, call your Clean Burn dealer. **DO NOT** overfire your furnace by turning up the compressed air. Overfiring will damage the combustion chamber and heat exchanger.
 - f. Vacuum the ash from the combustion chamber and the flues.
ATTENTION: When cleaning the combustion chamber, ensure that you do not gouge or damage the refractory material on the inside of the clean-out door.
NOTE: Avoid "packing" the ash in the tubes by first vacuuming the flues before pushing the flue brush down the flues. **DO NOT** bump or bend burner components while cleaning the combustion chamber.
 - g. Use a flue brush to thoroughly clean the flues.
 - h. Thoroughly vacuum any remaining ash residue from the flues. Make sure the back (at the breach) is still clean.
 - i. Check the flues for rust.
ATTENTION: The presence of rust in the flues indicates that chlorinated materials are being burned. Burning chlorinated materials will severely damage your heat exchanger. Contact your Clean Burn dealer for instructions to test your oil for chlorine contamination before firing your furnace.
 - j. Inspect the inside of the clean-out door. Make sure the refractory material on the inside of the clean-out door is in good condition and the clean-out door seals tightly when closed. If the door does not seal tightly, replace any damaged components.

Cleaning Ash From the Furnace (continued)

- k. Re-install the furnace components: Swing the clean-out door shut; install and tighten the lock-down nuts so that the door seals properly. Re-install the air and oil lines on the bottom of the connector block.

NOTE: You may need to bleed air from the oil line before starting the burner. See Section 5 for the pertinent instructions.

Cleaning the Check Valve / Screen

This procedure applies to furnace installations with inside and outside tanks. The following protective gear should be worn when cleaning the check valve/screen:

- Rubber gloves
 - Safety goggles
1. Refer to Figure 9E. Remove the one-piece suction oil line from the tank.
 2. Remove the check valve and screen. Clean these components in a parts washer.
 3. Check the operation of the check valve. The valve must seat so it is airtight to hold pump prime.
 4. Re-assemble and re-install the components. Apply Permatex #2 non-hardening gasket sealer or equivalent to the threaded fittings. Firmly tighten all connections so the suction line is 100% airtight.
 5. Follow pump priming instructions in Section 5 to re-establish prime.

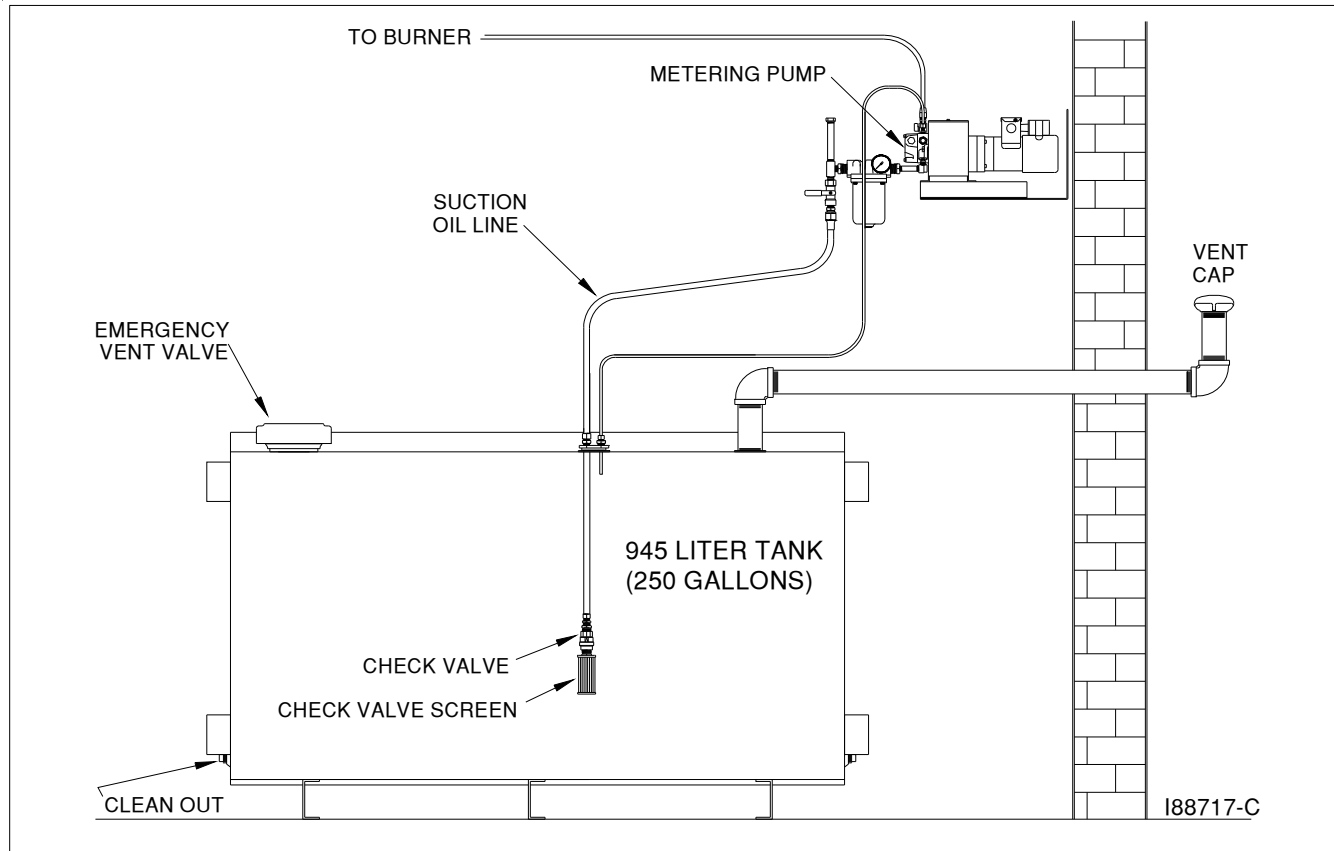

Figure 9E - Check Valve Detail

Cleaning the Tank

DO NOT allow water, sludge, or other debris to accumulate in your oil supply tank to the point that non-combustible or harmful materials are drawn into the pump or burner.

Drain water and sludge from the bottom of your tank at least once a year, and more frequently with water accumulation.

NOTE: If your used oil tank has not been cleaned on a regular basis, a considerable amount of sludge, etc. may have accumulated on the bottom of the tank. Under these circumstances, it is advisable for you to hire your used oil hauler to pump the tank. Make sure the tank is pumped to the bottom to remove all sludge, etc. from the tank (your used oil hauler may charge an additional fee for this type of service). The best time to pump the used oil tank is at the end of the heating season when the tank is low. This allows sufficient time to refill the tank with used oil (generated by your company over the summer months) so that you have adequate fuel for the heating season.

Annual Burner Tune-up

Your Clean Burn furnace requires annual periodic maintenance. The burner requires an annual tune-up --similar to an automotive tune-up--to keep it running in peak condition. *The burner tune-up should be performed by a qualified Clean Burn service technician who has the necessary parts and expertise..*

Contact your local Clean Burn dealer to schedule the annual periodic maintenance which is usually (preferably) performed during warm weather to prepare the furnace for the next heating season. Various levels of service are provided to fit your particular need.

End of Season Maintenance

ATTENTION: Turn main power to your furnace OFF at the end of the heating season. DO NOT operate your furnace during warm weather just to burn oil, or severe damage to the combustion chamber/heat exchanger may occur.

Contact your local Clean Burn dealer to schedule your annual burner tune-up. Allow only trained, authorized service personnel to service your burner.

SECTION 10: TROUBLESHOOTING

The following charts and tables are provided for reference in troubleshooting any difficulties encountered in furnace operation and adjustment.

- The **Flow Chart** outlines the proper sequence of events in furnace operation -- use this chart to help diagnose where a problem may be occurring.
- More specific troubleshooting information is provided in the **Troubleshooting Tables** following the flow charts. Each table lists a **Problem**, **Possible Cause**, and **Possible Action(s)** to fix the problem.

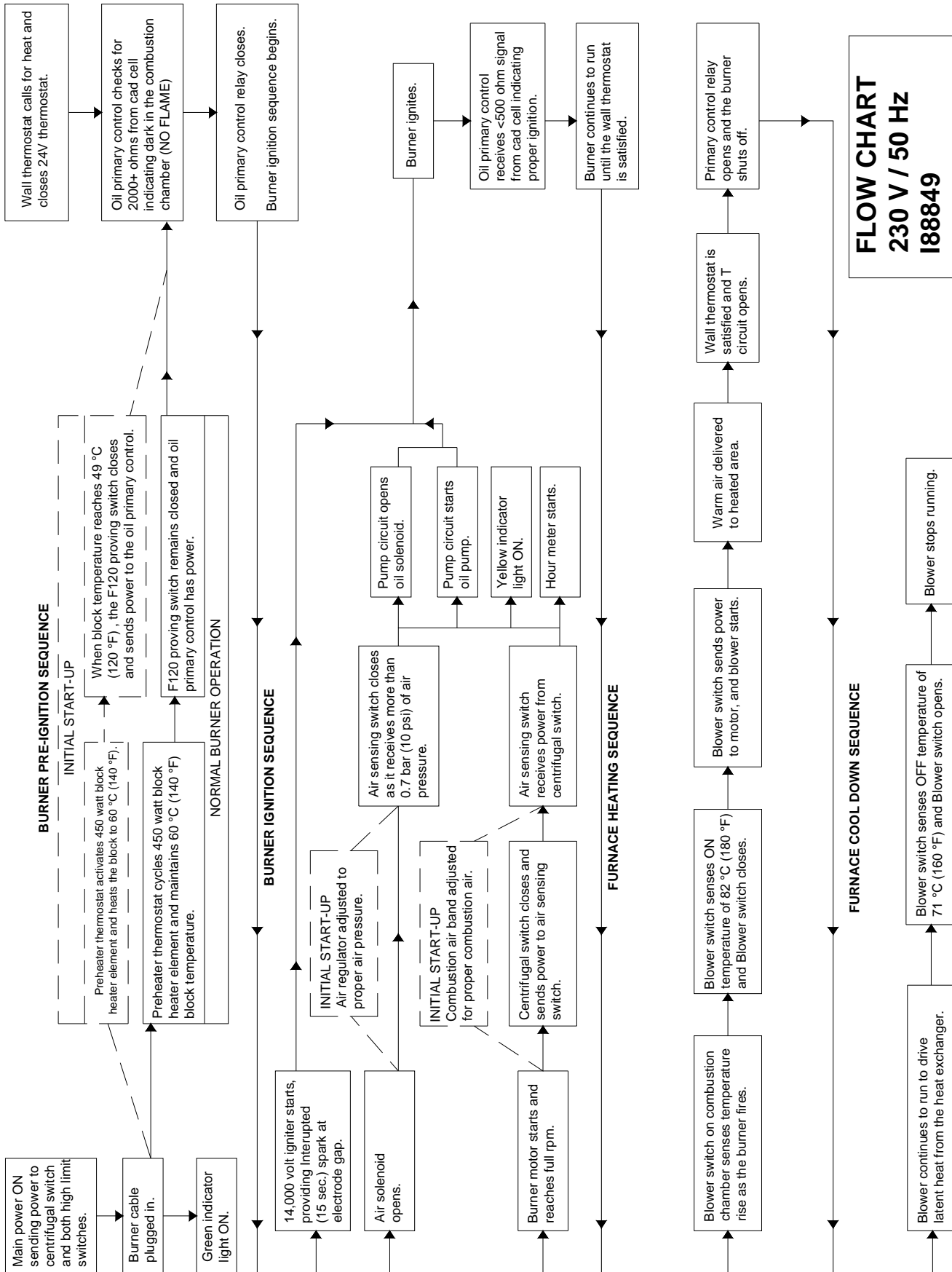

FLOW CHART
230 V / 50 Hz
I88849

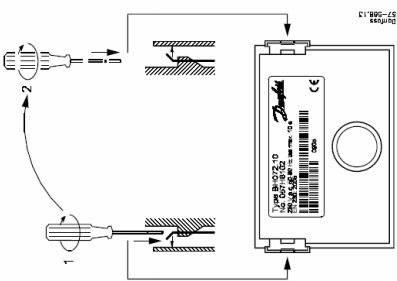
PROBLEM	POSSIBLE CAUSE	POSSIBLE ACTION(S)
<p>Burner won't run at all <i>and</i> Green power light is NOT ON.</p>	<ol style="list-style-type: none"> 1. Circuit breaker/main switch open. 2. Fuse/breaker blown. 3. Burner cable is damaged or not plugged in properly. 	<ol style="list-style-type: none"> 1. Close circuit breaker/switch. 2. Electrician should check out electrical system. 3. Check burner cable.
<p>Burner won't run at all <i>and</i> Green power light is ON.</p> 	<ol style="list-style-type: none"> 1. Oil primary control has shut down on safety reset. 2. Wall thermostat is not operating. 3. Heater block is not heating up. 4. F-120 proving switch has not closed. 5. Check the condition of the Oil primary control. 6. Oil primary control is damaged. 7. The L290 or L-290 limit switches have opened. 	<ol style="list-style-type: none"> 1. Follow the directions in Section 7 to reset the oil primary control. 2. Check the wall thermostat and thermostat cable. 3. Feel the back of the burner; it should be 60 °C (140 °F). If the heater block is NOT HOT: (a) Wait 15 minutes for the heater block to heat up and re-check the back of the burner, and (b) Check the block heater thermostat and block heater element. Refer to the wiring diagram and ladder schematic in Appendix B. 4. If the block is HOT: (a) Check the red wire at the F-120 proving switch for power. If there is NO power at the red wire, refer to the wiring diagram and ladder schematic in Appendix B to troubleshoot the circuit that provides power to the proving switch. (b) If there is power at the red wire at the proving switch, check for power at the black wire. If there is NO power at the black wire, replace the F-120 proving switch. 5. (a) Check the physical condition of the top primary control cover and the lower base to make sure there was no heat damage. (b) Disconnect the top cover of the primary control and check the base wiring. Follow the burner wiring label. 6. Replace oil primary control: (a) Check voltage – it must be 230 volts. 7. Test the switch for power. Note that power should be indicated on both sides of the switch. See section 7.

PROBLEM	POSSIBLE CAUSE	POSSIBLE ACTION(S)
<p>Burner ignites, but will not stay running <i>and</i> Burner shuts off on reset within 15 seconds.</p>	<ol style="list-style-type: none"> 1. There is a fuel delivery problem. 2. The cad cell is dirty. 3. Cad cell wires are loose. 4. Cad cell / cad cell wires are damaged. 5. The primary control is not receiving the proper μA signal from the cad cell. 	<ol style="list-style-type: none"> 1. Follow the procedures listed in the next problem. 2. Clean and check the condition of the cad cell and cad cell wires. 3. Check that the blue and black wires are connected properly into the primary base (terminals 11 and 12) 4. Replace the cad cell and cad cell wires. If the cad cell is heat damaged: (a) Clean your furnace, including the combustion chamber, flues and stack. Refer to instructions in Section 9. (b) Check for backdraft caused by exhaust fans in your building. Follow instructions in Section 8. 5. The photo current is measured with a direct current ammeter in series with the photo unit (+ pole on terminal 12). With a flame, cad cell current must be between $50\ \mu\text{A}$ and $210\ \mu\text{A}$ at 240V. With no flame, the measured photo current must be maximum $5\ \mu\text{A}$ at 230V.

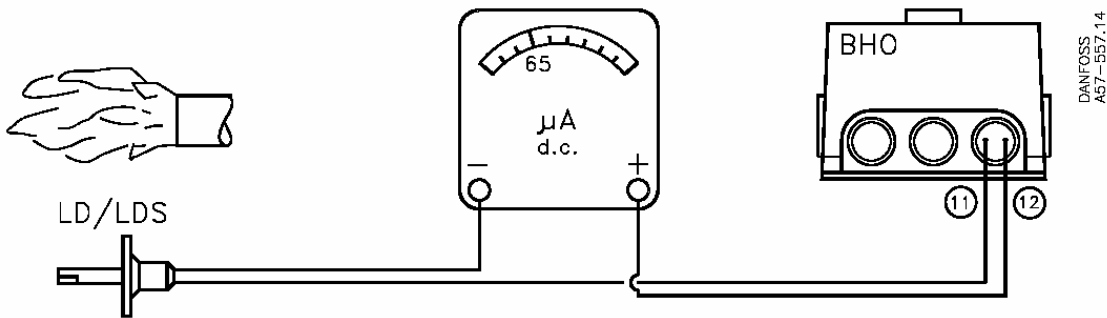

<p>Burner ignites and runs properly, but the burner shuts off on reset periodically (e.g. the burner goes off on reset during the night and requires resetting in the morning).</p>	<ol style="list-style-type: none"> 1. There is air in the suction oil line due to leaks at the fittings 2. There is air trapped in a high point in the pressure oil line. 	<ol style="list-style-type: none"> 1. Follow the procedures in Section 5 to vacuum test the pump. Re-install and properly seal the suction line fittings to eliminate air leaks. 2. Follow instructions in Section 4 to bleed the air out of the pressure oil line.
---	---	---

PROBLEM	POSSIBLE CAUSE	POSSIBLE ACTION(S)
<p>Burner ignites <i>and</i> Burner shuts off on reset sometime later during the day or night.</p>	<ol style="list-style-type: none"> 1. There is air in the fuel supply. 2. The primary control is not receiving the proper μA signal from the cad cell. 3. There is insufficient air pressure. 4. The heater block is cold. 5. The electrodes are fouled. 	<ol style="list-style-type: none"> 1. Prime the pump. If the pump will not prime or there is air in the oil stream from the pump bleeder, follow the steps in the next problem ("Pump will not prime.") 2. Check for proper μA signal. Follow the procedures in the previous problem (top, page 10-4) 3. Follow the instructions in Section 5 to adjust the air regulator for proper air pressure. DO NOT turn the air compressor off while the furnace is operating. If you turn the air compressor off at night, turn the wall thermostat to OFF so the burner will not run. 4. DO NOT shut off power to the furnace overnight, or the heater block will cool down, and the burner will not re-start the next morning. To turn the furnace "off" overnight, turn the wall thermostat to OFF. The heater block will stay hot. 5. If oil residues have built up on the electrodes and retention head, follow the instructions in Section 8 to check for proper draft overfire. Clean the electrodes and retention head.

PROBLEM	POSSIBLE CAUSE	POSSIBLE ACTION(S)
<p>Pump will not prime <i>and</i> Pump motor is running.</p>	<ol style="list-style-type: none"> 1. There is a leak(s) in the suction line. 2. The pump is not installed so it will fill with oil during the priming process. 3. The pump gears are dry. 4. The pump seal is damaged. 5. The ball valve is closed. 6. The canister filter is dirty. 7. The check valve is dirty. 8. The pump is damaged or worn out. 	<ol style="list-style-type: none"> 1. Follow the specifications in Section 4 to make sure the suction line is installed properly and that all fittings are 100% airtight. 2. Make sure the pump head is filled with oil prior to starting the pump. See Section 5. 3. Follow the procedure in Section 5 to fill the oil line and prime the pump. 4. With the pump not running, wipe your finger along the bottom of the cylinder at the pump shaft. If there is oil at the pump shaft, the seal is damaged. Replace the pump, or replace the seal. NOTE: Some oils will expand as they warm up. Because there is a check valve in the suction line, the expanding oil may build up pressure and damage the oil seal. Install a mini-accumulator in the 1/8" port of the canister filter to prevent the pressure build-up. 5. Open the ball valve on the suction line. 6. Refer to Section 9 to clean the canister filter. 7. Refer to Section 9 to clean the check valve. 8. Replace the pump.

PROBLEM	POSSIBLE CAUSE	POSSIBLE ACTION(S)
<p>Pump will not prime <i>and</i> Pump motor is NOT running.</p>	<ol style="list-style-type: none"> 1. There is NO power on the pump circuit from the burner. 2. The pump motor has shut off on thermal overload. 	<ol style="list-style-type: none"> 1. Start the burner and adjust the air pressure regulator to 15 PSI. (a) If the amber "pump" light on the burner comes ON, the pump circuit on the burner has activated properly. Refer to the wiring diagram and ladder schematic in Appendix B to troubleshoot the pump circuit from the burner to the pump. (b) If the amber "pump" light on the burner does NOT come ON, there is a problem with pump circuit in the burner. With the burner running, check for power at the brown wire on the air pressure switch. If there is NO power at the brown wire, replace the burner motor. If there is power at the brown wire, replace the air sensing switch. 2. (a) The pump motor is too hot—the internal thermal protection switch shut the motor off. Wait for the motor to cool down; the thermal switch will automatically reset. Check voltage and amperage draw of the pump motor. Call your dealer if the problem persists. (b) The coupling is not adjusted properly, keeping the shafts of the motor and pump from turning freely. Re-position the coupling so that both shafts turn freely. (c) The shaft on the motor or oil pump will not turn freely. If you can't turn the shafts, replace the faulty part(s).
<p>Blower motor runs all the time.</p>	<ol style="list-style-type: none"> 1. Blower motor circuit is wired incorrectly. 	<ol style="list-style-type: none"> 1. Refer to wiring diagram and ladder schematic in Appendix B to troubleshoot the blower motor circuit.
<p>Blower motor will not run.</p>	<ol style="list-style-type: none"> 1. The blower motor is not wired correctly. 2. The Blower / Fan switch is defective. 3. The blower motor has overheated and shut down on thermal reset. 	<ol style="list-style-type: none"> 1. Check the blower motor wiring. Refer to the wiring diagram and ladder schematic in Appendix B. Follow the directions in Section 6 to test for proper fan operation. If the fan does not operate, shut OFF power to the furnace and call your Clean Burn dealer for service. 2. Replace the Blower / Fan switch. 3. Check voltage and amperage draw of the blower motor. Call your dealer if the problem persists.

APPENDIX A

Detailed Furnace Specifications

Furnace Technical Specifications

Furnace Model	CB-1500	CB-2500
Input	44 KW @ 4 LTR/HR (150,000 @ 1.1 GPH)	77 KW @ 6.4 LTR/HR (250,000 @ 1.7 GPH)
Listed Fuels	#2, #4, and #5 fuel oils used crankcase oil used ATF used hydraulic oil	#2, #4, and #5 fuel oils used crankcase oil used ATF used hydraulic oil
Cabinet Dimensions (L x W x H)	1320 x 673 x 673 mm (52 x 26.5 x 26.5 in)	1830 x 673 x 673 mm (72 x 26.5 x 26.5 in)
Furnace Dimensions (L x W x H) with Blower, Burner, Louvers	2115 x 750 x 743 mm (83.25 x 29.5 x 29.25 in)	2623 x 743 x 800 mm (103.25 x 29.25 x 31.5 in)
Approximate Weight	145 kg (320 lbs.)	154 kg (340 lbs.)
Mounting	1) ceiling hung 2) raised platform 3) non-combustible platform	1) ceiling hung 2) raised platform 3) non-combustible platform
Electrical Requirements	230 V / 50Hz 10.9 Amps	230 V / 50 Hz 11.3 Amps
Circuit Breaker	15 Amps	15 Amps
Wall Thermostat	24 volt	24 volt
Oil Pump	Suntec A2RA-7710	Suntec A2RA-7710
Pump Motor	1/17 HP Bison gear motor	1/17 HP Bison gear motor
Pump Motor Rotation	CCW (shaft end)	CCW (shaft end)
Canister Filter	Lenz DH 750-100	Lenz DH 750-100
Stack Size	203mm (8")	203mm (8")
Blower Motor HP	3/4 HP	1 HP
Blower Wheel Size	27 cm dia. x 27 cm wide (10-5/8" dia. x 10-5/8" wide)	30 cm dia. x 28 cm wide (12" dia. x 11" wide)
Blower/Fan Switch	82 °C (F180)	82 °C (F180)
Hi-Temp Limit Switch	93 °C (L200)	93 °C (L200)
Auxiliary Hi-Temp Limit Switch	143 °C (L290)	143 °C (L290)

Burner Technical Specifications

Burner	CB-500-CE-5W
Ignition Transformer	Danfoss (14,000 Volts)
Nozzle	Delavan 9-5
Burner Motor	1/10 HP 2800 RPM with centrifugal switch
Burner Motor Rotation	CCW shaft end
Compressed Air Requirements	0.06 CMM @ 1.7 Bar (2.0 CFM @ 20 PSI)
Oil Primary Control	Danfoss
Heater Element in Preheater Block	450 watts
Air Pressure Switch	MPL 808
Setting for Preheater Thermostat	60 °C (140 °F)

Furnace Dimensions

FURNACE DIMENSIONS

CB-2500

NOTE: MEASUREMENT FROM BOLT CENTER
TO BOLT CENTER IS 1753 mm (69 IN.)

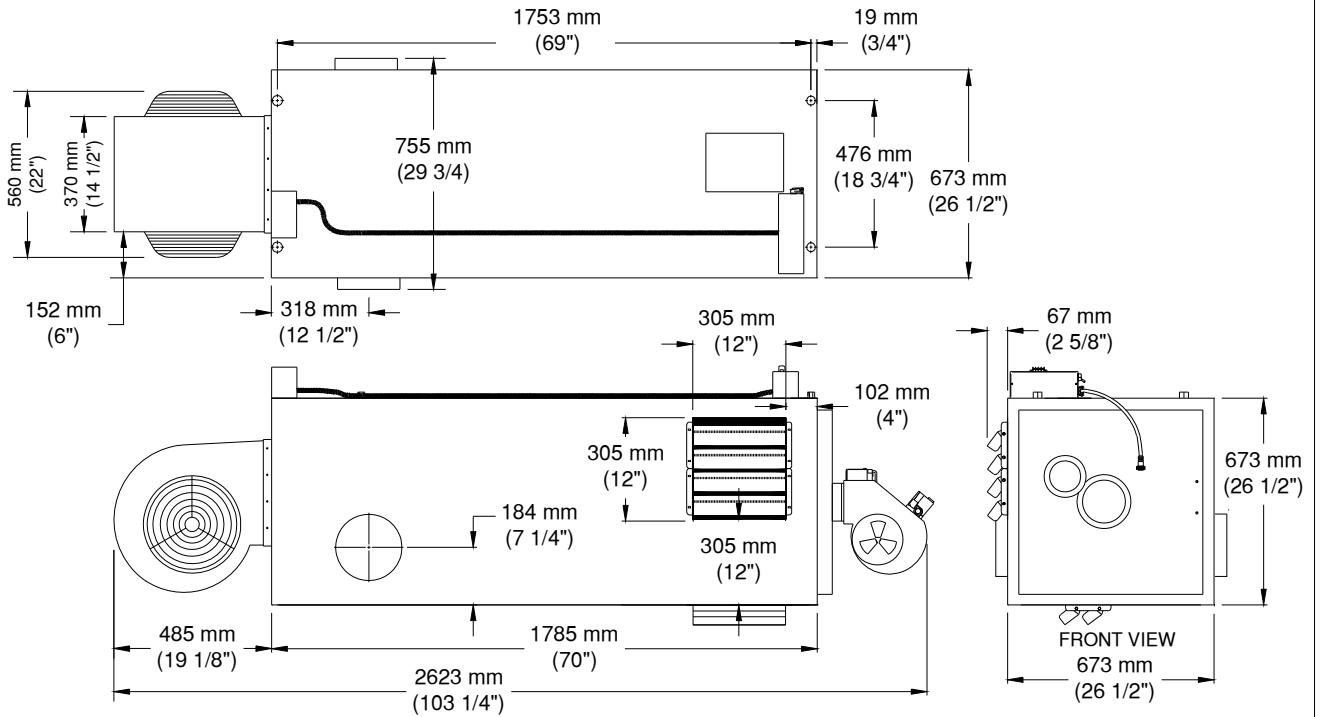

CB-1500

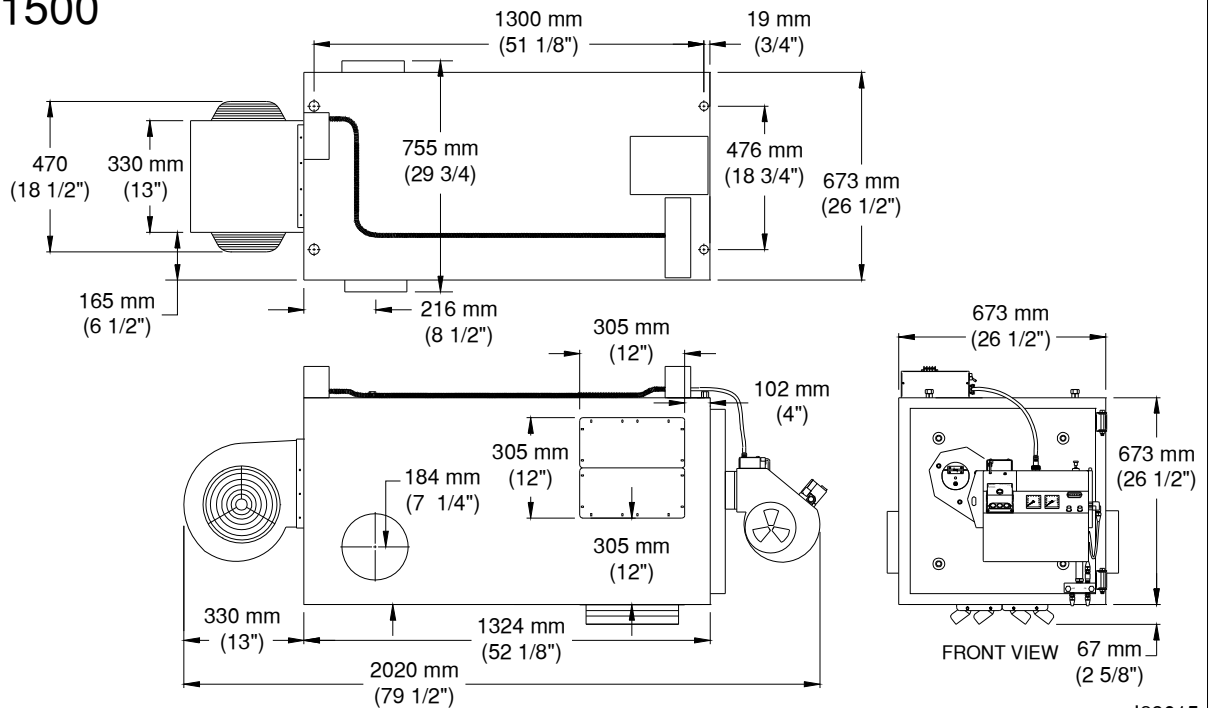

189015

Burner Components

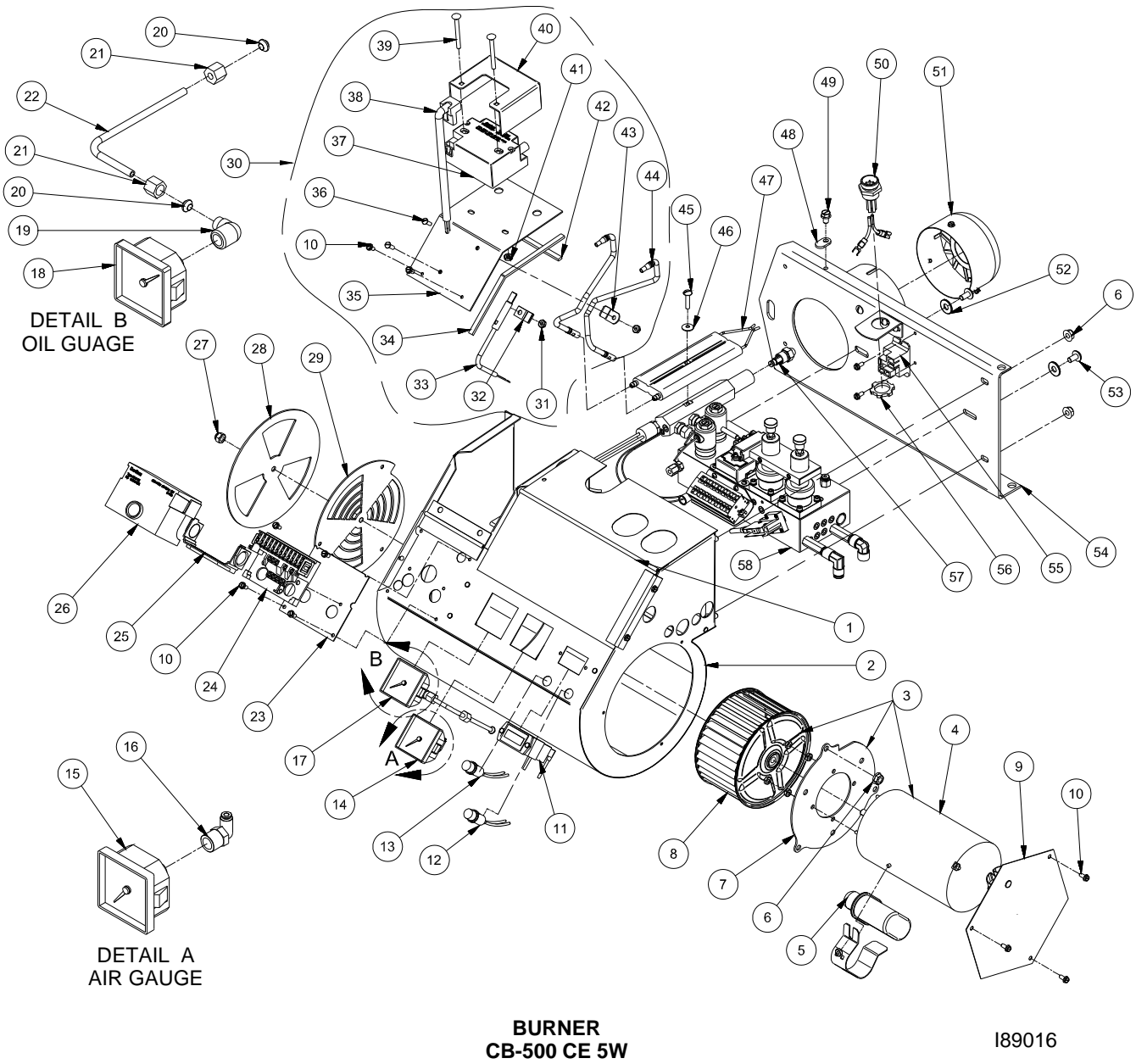

Figure A1 - CB-500-CE 5W Burner Component Detail

Burner Components (continued)

<u>Item #</u>	<u>Part #</u>	<u>Description</u>	<u>Item #</u>	<u>Part #</u>	<u>Description</u>
1	11265	COVER - HINGED W A	44	33528	SPARK PLUG CABLE
2	11335	HOUSING A	45	34326	10-32 X 7/8 SLOTD PAN HD SCREW
3	12230	BLOWER MOTOR A INT'L	46	34165	#12 X 9/16 BONDED NEOPRENE
4	33337	MOTOR CB 500-I BURNER	47	33527	ELECTRODES, PLUG-IN
5	70439	CAP 1 MFD - 660v 50/60Hz	48	26078	TRANSFORMER LID TAB
6	34092	1/4-20 HEX SER FLANGE NUT	49	34155	1/4-20 X 1/2 SLOTTED HEX WASHR
7	26044	MOTOR MOUNT PLATE	50	12285	CONNECTOR RECEPTICAL ASSY
8	31113	FAN SQUIRREL CAGE	51	11308	RETENTION HEAD A. S-40
9	14085	RIGHT SIDE COVER A	52	34052	1/4 USS FLAT WASHER ZINC
10	34178	8-32 X 3/8 SLOTTED HEX W/F	53	34000	1/4-20 X 1/2 SLOT TRUSS M/S Z
11	33161	HOURLMETER (50 HZ)	54	11334	HINGE MOUNT PLATE WA
12	33338	AMBER LIGHT (230 V INT'L)	55	33529	COIL RELAY 240V AC 30A
13	33166	GREEN LIGHT (230 V INT'L)	56	33250	LOCKNUT-CONDUIT 1/2
14	14087	GAUGE 0-60 A	57	32000	NOZZLE 9-5 (30609-5 BULK)
15	32179	SQUARE GAUGE 0-60	58	13156	HEATER BLOCK A CB 500 I
16	32253	FEM EL 1/8TPX 1/8NPT		11555	BURNER CB-500-CE 5W
17	14086	GAUGE 0-15 A			
18	32178	SQUARE GAUGE 0-15			
19	32473	CON FEM ELL BODY ONLY			
20	32198	SLEEVE 3/16 OD TUBE			
21	32197	NUT 3/16 OD TUBE			
22	54020	TUBING COPPER 3/16			
23	26122	PLATE PRIMARY			
24	33522	BASE BHO 64 PRIMARY			
25	33523	FRONT PLATE			
26	33521	PRIMARY BURNER CONTROL BHO 64			
27	34124	1/4-20 ESNA NUT NE ZINC			
28	26103	PLATE - AIR FLOW OUTER			
29	11359	INNER DRAFT PLATE A			
30	11551	IGNITER PLATE ASSY			
31	34172	LOCK NUT (KEPS) 8-32 Z			
32	33208	WIRE CLAMP			
33	33525	PHOTO UNIT LD			
34	31159	GASKET 1/8" THICK			
35	26120	IGNITER PLATE			
36	34061	8-32 X 1/2 SLOTTED ROUND M/S Z			
37	33524	IGNITER, DANFOSS			
38	33526	PRIMARY CABLE w/ PLUG			
39	34403	CARRIGE BOLT 10/24 x 2			
40	26121	IGNITER COVER			
41	34404	NUT 10/24			
42	31158	GASKET-SHORT. 1.25"x.25"x3.8125"			

Burner Components (continued)

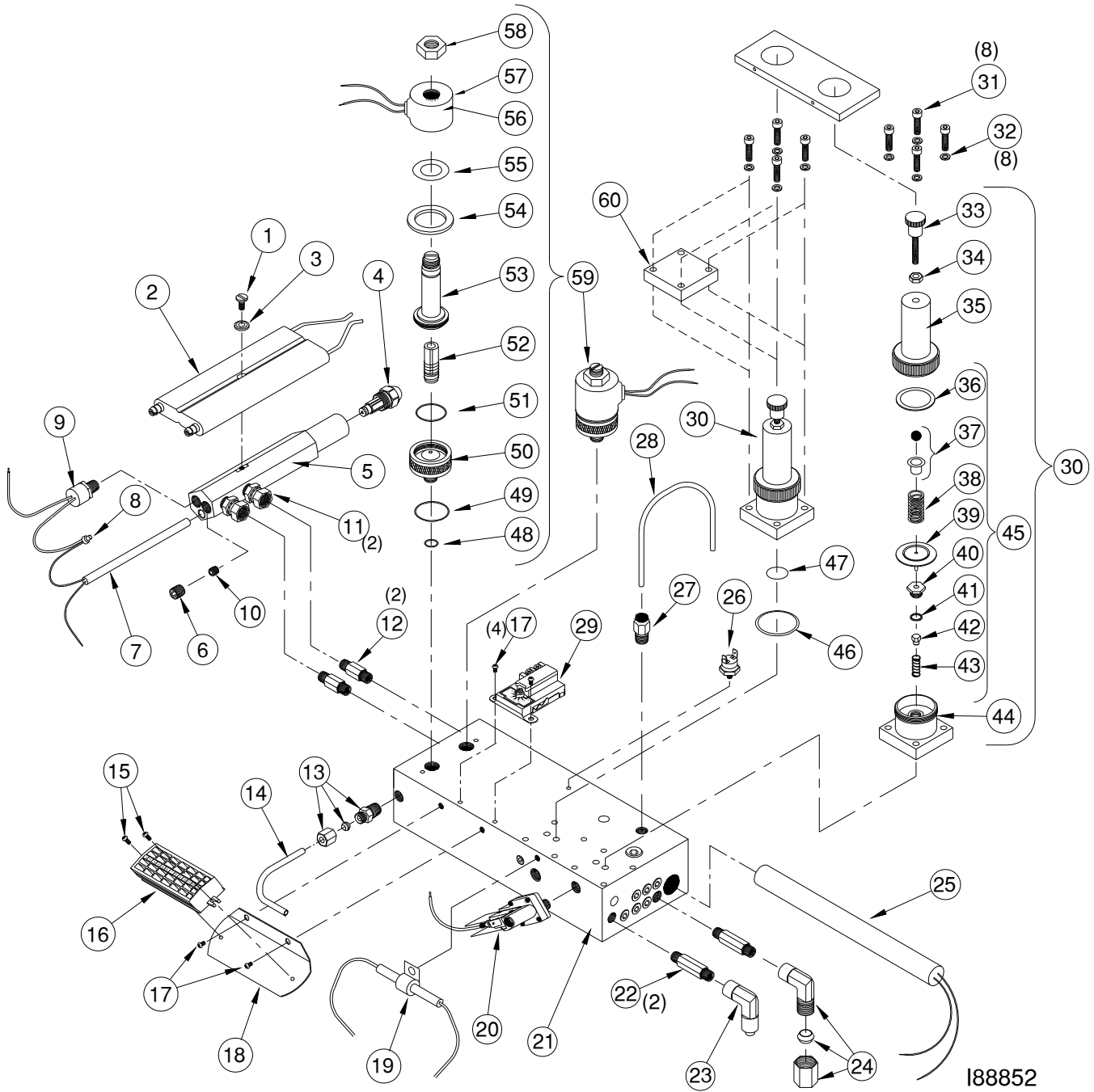

Figure A2 - Preheater Block and Electrode Assembly Component Detail

Burner Components (continued)

<u>Item#</u>	<u>C.B. Part#</u>	<u>Qty.</u>	<u>Component Description</u>
1	34169	1	ELECTRODE SCREW - 10-32 x 3/4
2	33527	1	PLUG IN ELECTRODE
3	34165	1	WASHER
4	32000	1	9 - 5 NOZZLE
5	13150	1	NOZZLE ADAPTOR
6	32007	1	PLUG - 1/8 NPT
7	33375	1	140 WATTS HEATER
8	33381	1	INSULATED CAP CRIMP CONNECTOR
9	33418	1	THERMOSTAT L-130
10	32199	1	PLUG - 1/16 NPT
11	32050	2	SWIVEL FITTING
12	32189	2	HEX NIPPLE - 1/8 NPT x 1-1/2
13	32043	1	MALE CONNECTOR - 3/16T x 1/8 NPT
14	54020	1	3/16 COPPER TUBING(OIL GAUGE LINE)
15	32201	2	MACH. SCREW PHILLIPS HD. 6-32 x 3/8 Z
16	33247	1	TERMINAL BLOCK
17	34036	4	MACH. SCREW PHILLIPS HD. 6-32 x 1/4 Z
18	26059	1	TERMINAL BLOCK BRACKET
19	33278	1	THERMAL CUT-OFF
20	33057	1	AIR PRESSURE SWITCH
21	26090	1	HEATER BLOCK
22	32190	2	HEX NIPPLE - 1/8 NPT x 2
23	32202	1	FEMALE ELBOW (FOR 1/4" AIR LINE)
24	32201	1	FEMALE ELBOW (FOR 3/8" OIL LINE)
25	33289	1	PRE-HEATER ELEMENT (450 WATTS)
26	33378	1	PROVING SWITCH (NORMALLY OPEN)
27	32325	1	MALE ELBOW 1/8 x 1/8 NPT (FOR AIR GAUGE LINE)
28	54020	1	3/16 COPPER TUBING(OIL GAUGE LINE)
29	33011	1	HEATER BLOCK THERMOSTAT(NORMALLY CLOSED)
30	32359	2	REGULATOR SURFACE MOUNT
31	34148	8	REGULATOR MOUNTING SCREW
32	34114	8	LOCK WASHER #8 Z
33	34147	2	REGULATOR THREADED STEM
34	34022	2	HEX NUT - 10-32 Z
35	32306	2	BONNET
36	32226	2	DIAPHRAM RING
37	32364	2	CAP AND BALL ASSEMBLY
38	32227	2	COMPRESSION SPRING
39	32360	2	DIAPHRAM
40	32361	2	BRASS POPPET SEAT
41	32223	2	POPPET 'O' RING
42	32222	2	POPPET VALVE
43	32221	2	POPPET SPRING
44	32362	2	BASE
45	13142	2	REGULATOR KIT COMPONENTS
46	32308	2	REGULATOR OUTER "O" RING
47	32309	2	REGULATOR INNER "O" RING
48	33311	2	SOLENOID INNER "O" RING
49	33312	2	SOLENOID OUTER "O" RING
50	33313	2	MANIFOLD MOUNT SOLENOID BODY
51	33314	2	BODY "O" RING
52	33315	2	PLUNGER ASSEMBLY
53	33316	2	PLUNGER GUIDE ASSEMBLY
54	33317	2	FLUX PLATE
55	33318	2	WASHER SEAL
56	33384	2	COIL (230 V)
57	33320	2	COIL HOUSING
58	33321	2	NUT
59	33371	2	AIR/OIL SOLENOID ASSEMBLY (230 V)
60	26107	1	REG. SQUARE CAP

Burner Components (continued)

INSTALLATION OF THE SPINNER RETENTION HEAD

THE SPINNER RETENTION HEAD FITS INSIDE THE BURNER TUBE AND REQUIRES (3) SELF-TAPPING SCREWS. IT IS VERY IMPORTANT THAT THE SPINNER HEAD IS NOT TIPPED FROM SIDE TO SIDE OR FROM TOP TO BOTTOM.

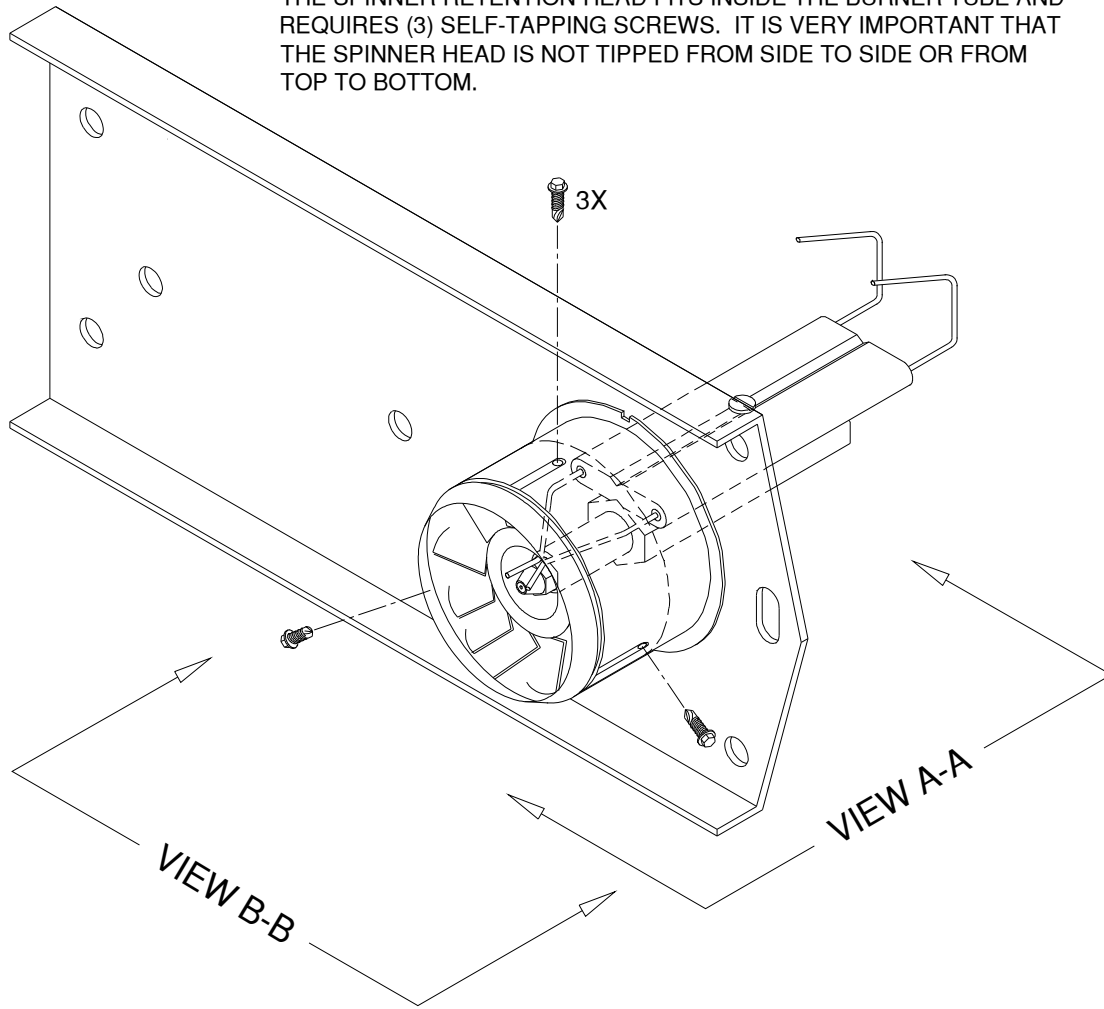

USE PROVIDED SCREWDRIVER AS WEDGE TO HOLD THE SPINNER RETENTION HEAD IN POSITION. THEN TIGHTEN THE THREE SCREWS TO LOCK THE HEAD IN POSITION.

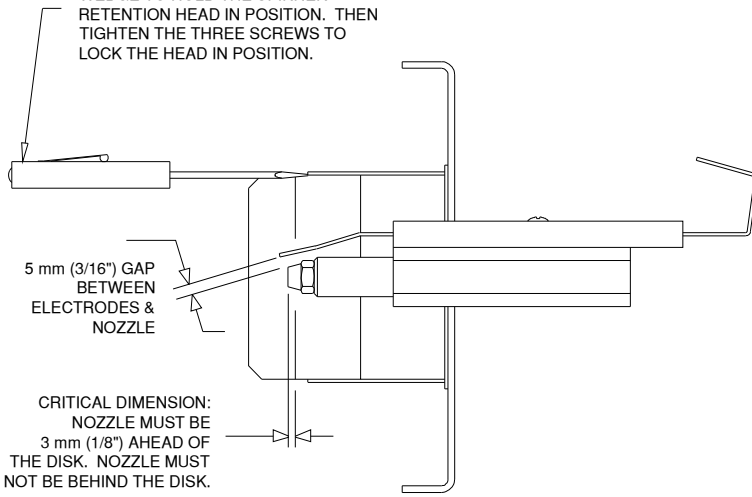

SIDE VIEW A-A

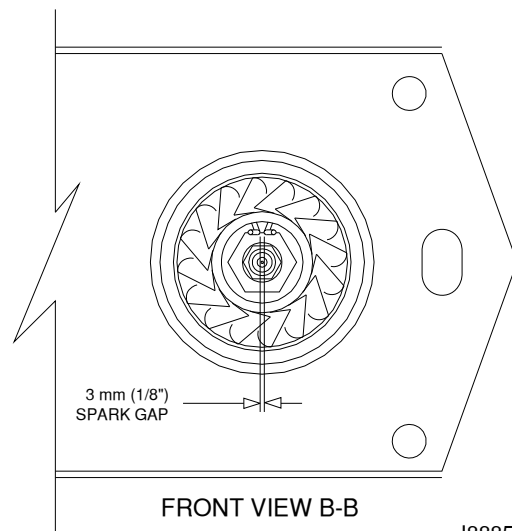

FRONT VIEW B-B

188850

Figure A3 - Burner Electrode Specifications with Spinner Retention Head

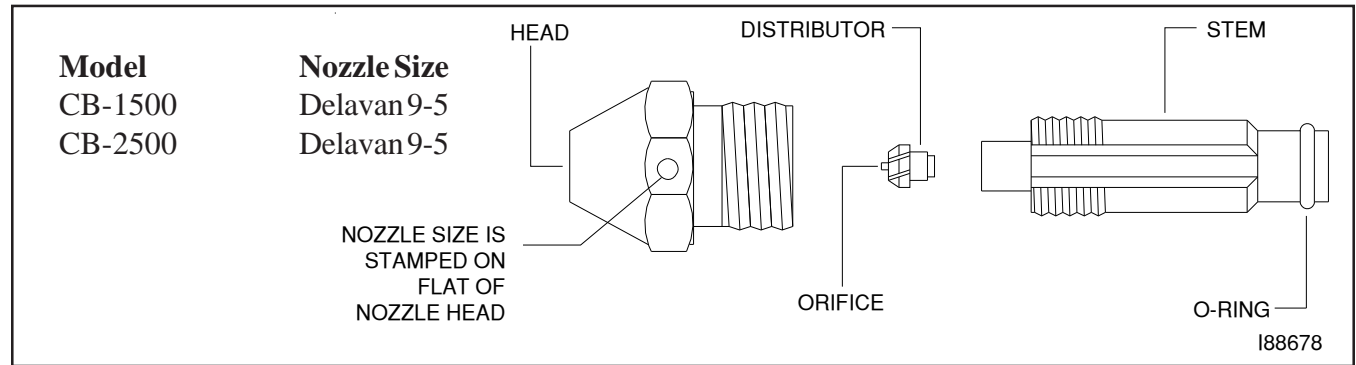
Burner Components (continued)**Removing the Nozzle for Cleaning:**

NOTE: Due to swivel fittings on the air and oil lines, it is not necessary to disconnect these lines when swinging the burner open.

1. Remove the lock-down nut on the mounting flange bolt.
2. Disconnect the burner power cable.
3. Carefully swing the burner open to its maintenance position.
4. Remove the nozzle from the nozzle adapter with a 5/8" socket.

Cleaning the Nozzle:

1. Unscrew the stem from the nozzle head.
2. Spray WD-40 or equivalent through the orifice to thoroughly remove any blockage.
CAUTION: DO NOT damage or deform the nozzle orifice; DO NOT use a torch tip cleaner or other inappropriate device to clean the orifice. If the blockage is a "tarry" material or a hard, black material, call your Clean Burn dealer for service.
3. Flush all components with WD-40 to remove oil residues.
4. Reassemble the nozzle components. When tightening the stem, just barely "snug" it down. DO NOT overtighten.
5. Check the O-ring on the nozzle stem. Replace the O-ring if it is in the least bit cut or deformed.
6. Lubricate the O-ring on the nozzle stem with a couple of drops of new motor oil, then re-install the nozzle.
7. Check the electrodes for proper gap and clearances. (Figure A3)
8. Re-install the burner and adjust for optimal performance as described in Section 6.

NOTE: If the nozzle plugs within a few days after cleaning, call your Clean Burn Dealer for service.

Figure A4 - Cleaning the Nozzle

CB-1500 Furnace Components

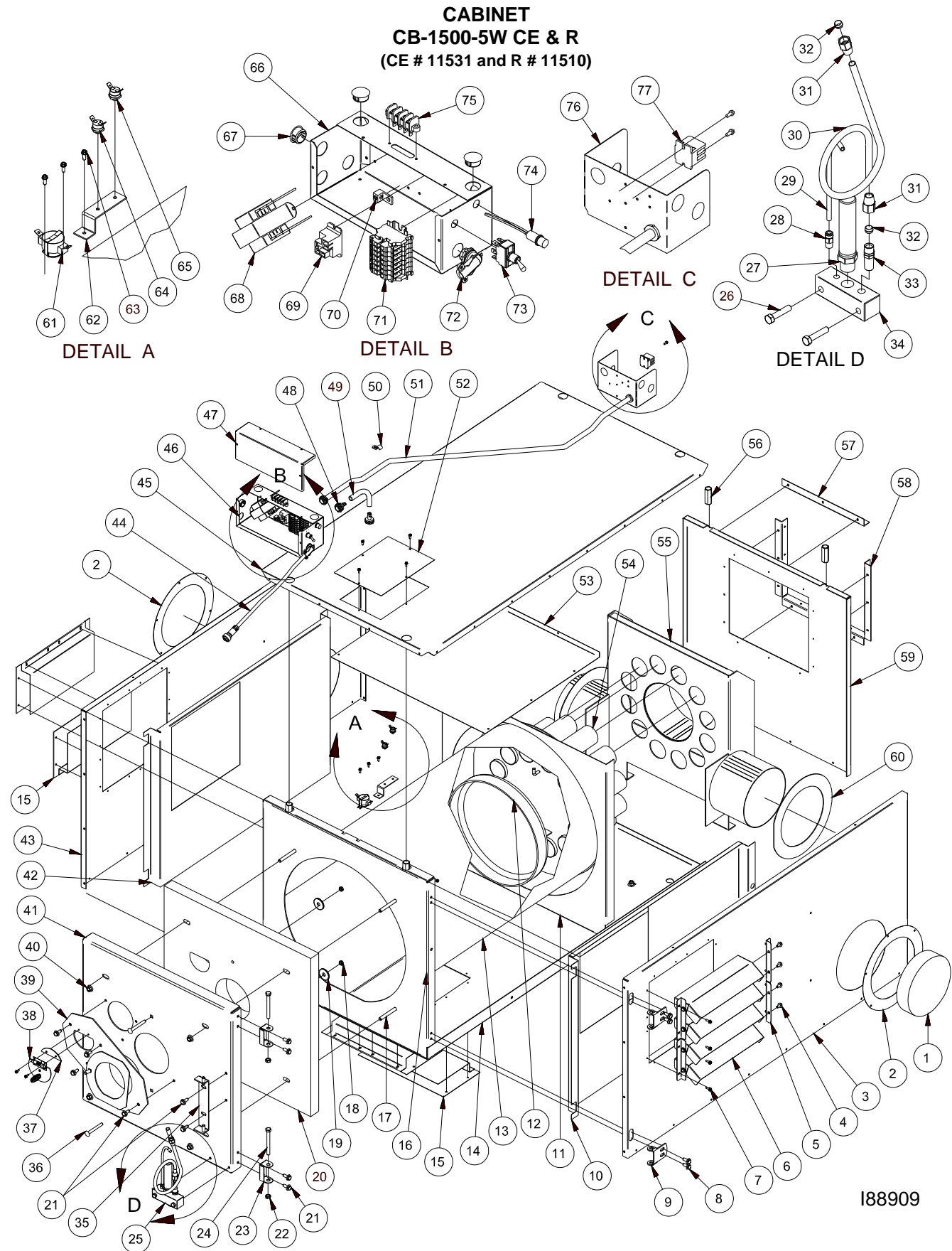

188909

Figure A5 - CB-1500 Furnace Component Detail

CB-1500 Furnace Components (continued)

Item #	Part #	Description	Item #	Part #	Description
1	31091	DUCT CAP ROUND 8"	50	33142	CLAMP 3/8 FLEX CONDUIT or 1/4
2	21010	STACK PIPE FLASH RING	51	12249	FLEX CONDUIT R.W. 3/8 X 43"
3	29083	SHROUD RIGHT	52	29090	SWITCH COVER
4	34054	1/4-20 X 1/2 HEX FLANGE SCREW	53	29114	TOP HEAT SHIELD (CB-1502)
5	29069	ANGLE LVR CB-1502 / 2501	54	23091	FLUE TUBE CB1502/1750
6	29070	LOUVER	55	11485	FURNACE WELD ASSY CB-1502 / 1750
7	34116	10 X 5/8 HEX WASHER HEAD TEK Z	56	34007	5/8-11 X 2 1/8 ROD COUPLNG NUT
8	34028	5/16-18 X 3/4 SERR HEX FLANG	57	29094	ANGLE BLOWER SHORT
9	29045	HINGE	58	29093	ANGLE BLOWER LONG
10	29112	SIDE SHIELD LFT (CB-1502,2501)	59	29085	SHROUD BACK CB-1500
11	29088	PLATE (STATIC) AIR FLOW	60	29096	SEAL STACK RING
12	31232	ENERGY RETENTION DISC	61	33230	FAN SWITCH - SURFACE MOUNT 180
13	29056	COMB CHAMBER	62	29068	BRACKET TEMP HI LIMIT
14	29095	BASE	63	34004	#8 X 1/2 WASHER HEAD TEK SCREW
15	29115	COVER DISCHARGE CLOSURE PANEL	64	33288	AUXIL HI LIMIT-AUTO RESET 290
16	29059	FRAME FRONT	65	33390	SWITCH TEMP (HL)
17	34179	3/8-16 X 3 HHCS GR-5	66	21169	E-BOX 5W
18	34121	5/16-18 TOP LOCK NUT S.S.	67	33131	KNOCK-OUT SEAL/PLUG
19	21039	.438 X 1.5 X .135 FLAT WASHER	68	33340	TRANSFORMER 24-240V
20	31183	INSULATION	69	33544	RELAY-COIL 24 VAC 30A
21	34118	5/16-18 X 3/4 HEX WASHER HEAD	70	33145	SCREW LUG
22	34095	3/8-16 STOVER L/N GR-B CAD/WAX	71	33486	TERMINAL BLOCK A (SCREW)
23	21056	HINGE BRACKET	72	33000	CONNECTOR 90 DEG. THREAD & NUT
24	34119	3/8-16 X 3 HHCS GR-2 ZINC	73	33286	SWITCH DPDT ON-ON
25	14230	HOOK-UP KIT CB-1502/1750/2501	74	33168	AMBER LIGHT
26	34051	5/16-18 X 1 1/2 HHCS GR-2 ZINC	75	33331	TERMINAL BLOCK (4 POST) CTB
27	32311	ACCUMULATOR	76	21164	E-BOX 6 X 4 X 3 3/4
28	32039	ADAPT 1/4 OD X 1/8 P	77	33468	TERMINAL BLOCK (2 CIRCUIT)
29	13119	AIR LINE A			
30	13125	OIL LINE A			
31	32304	NUT - LONG			
32	32303	SLEEVE			
33	32245	SWIVEL 1/4NPTM,1/4NPTF			
34	21101	CONNECTOR BLOCK			
35	11033	HINGE BRACKET W A			
36	34120	5/16-18 X 2 3/4 CARR BOLT S.S.			
37	21076	PORT CAP			
38	11325	INSPECTION DOOR A			
39	11143	BURNER MOUNT W A			
40	34009	3/8-16 HEX SERR FLANGE NUT PLT			
41	29044	DOOR CB-2501/1502			
42	29113	SIDE SHIELD RT. (CB-1502,2501)			
43	29082	SHROUD LEFT			
44	33479	CONNECTOR PLUG 5-WIRE 25"			
45	29084	SHROUD TOP			
46	12292	JUNCTION BOX A			
47	21170	E-LID			
48	33267	CONNECTOR (ID Screw In Type)			
49	33469	FLEX CONDUIT R.W. 3/8 X 5"			

CB-2500 Furnace Components

**CABINET
CB-2500 CE & R 5W
(CE # 11480 and R # 11511)**

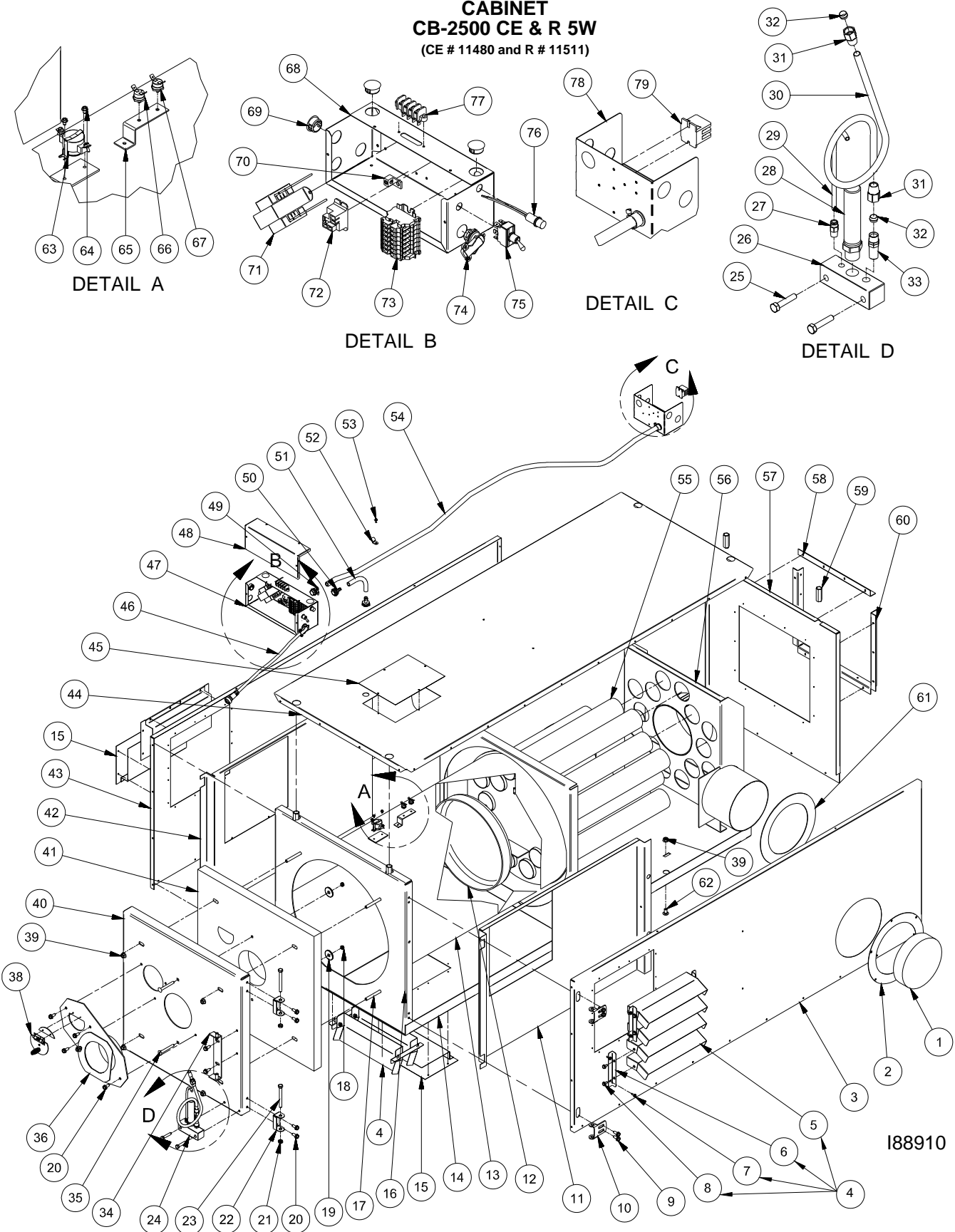
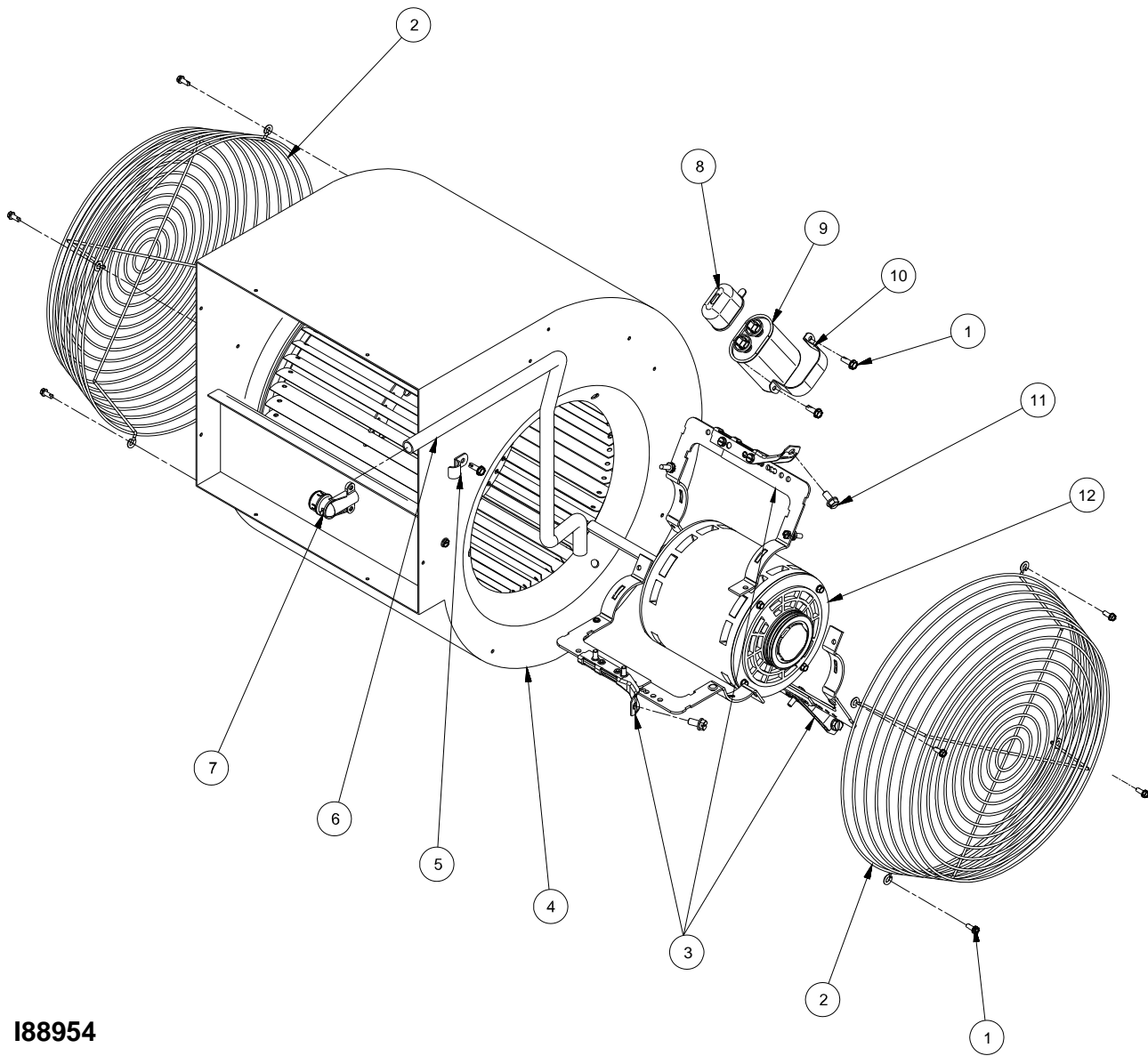

Figure A6 - CB-2500 Furnace Component Detail

CB-1500 Blower Components

**BLOWER ASSEMBLY
CB-1500**



I88954

Figure A7 - CB-1500 Blower Component Detail

CB-1500 Blower Components (continued)

ITEM#	PART#	DESCRIPTION
1	34116	10 X 5/8 HEX WASHER HEAD TEK Z
2	31191	GUARD DD BLOWER
3	31204	BRACKET KIT - 3/4 HP MOTOR EA
4	31199	BLOWER DD 1502 10-10A
5	33142	CLAMP 3/8 FLEX CONDUIT or 1/4
6	33470	FLEX CONDUIT R.W. 3/8 x 19"
7	33000	CONNECTOR 90 DEG. THRD & NUT
8	33422	CAPACTR BONNET (RUBBER CAP)
9	33608	CAPACTR RUN 370-V 20-Mfd
10	33454	CAPACTR STRAP-Hold Down Clamp
11	34159	1/4 X 3/4 SLOTTED IND HEX
12	33574	MOTOR 3/4 HP 230V/50Hz
	33055	WIRE PROTECTOR (anti-short)
	43205	INSTRUCTION SHEET
	14328	BLOWER CB-1500 CE ASSEMBLY

CB-2500 Blower Components

**BLOWER ASSEMBLY
CB-2500**

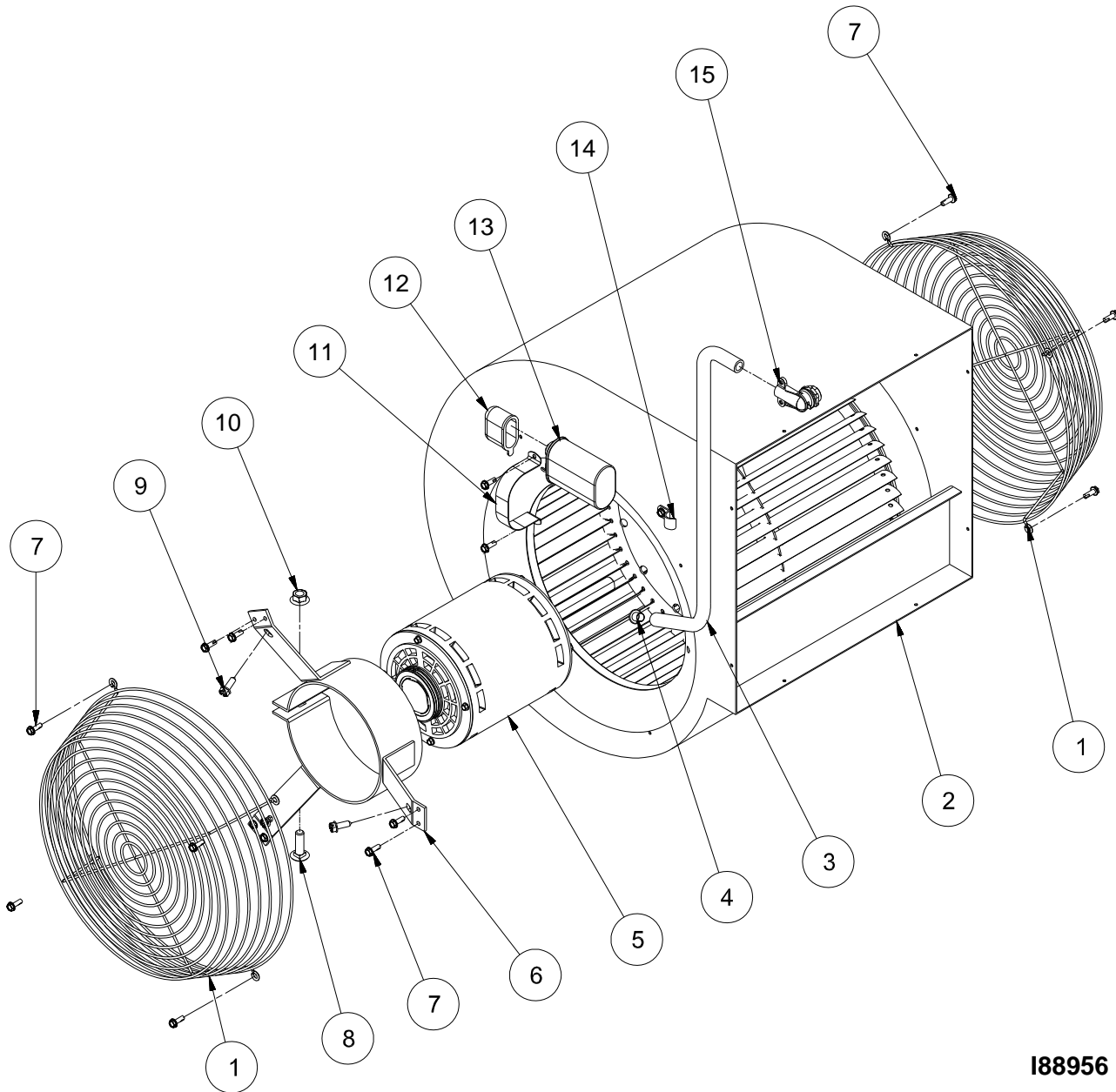

188956

Figure A8 - CB-2500 Blower Component Detail

CB-2500 Blower Components (continued)

ITEM#	PART#	DESCRIPTION
1	31191	GUARD DD BLOWER
2	31189	BLOWER CB-2500
3	12057	FLEX CONDUIT RW 3/8 X 23
4	33055	WIRE PROTECTOR (anti-short)
5	33575	MOTOR 1 HP 230V/50Hz
6	11482	MOTOR MOUNT WELD
7	34116	10 X 5/8 HEX WASHER HEAD TEK Z
8	34035	CB 3/8-16 X 1.25 G5 Z
9	34159	1/4 X 3/4 SLOTTED IND HEX
10	34009	3/8-16 HEX SERR FLANGE NUT PLT
11	33416	CAPACTR STRAP-Hold Down Clamp
12	33422	CAPACTR BONNET (RUBBER CAP)
13	33608	CAPACTR RUN 370-V 20-Mfd
14	33142	CLAMP 3/8 FLEX CONDUIT or 1/4
15	33000	CONNECTOR 90 DEG. THRD & NUT
	14326	BLOWER CB-2500 CE DD ASSEMBLY
	42365	LABEL (TO REMOVE SHPING BRKT)
	43163	CAUTION INSTRUCTION SHEET

APPENDIX B

Wiring Diagrams

CB-1500/2500-CE 5W

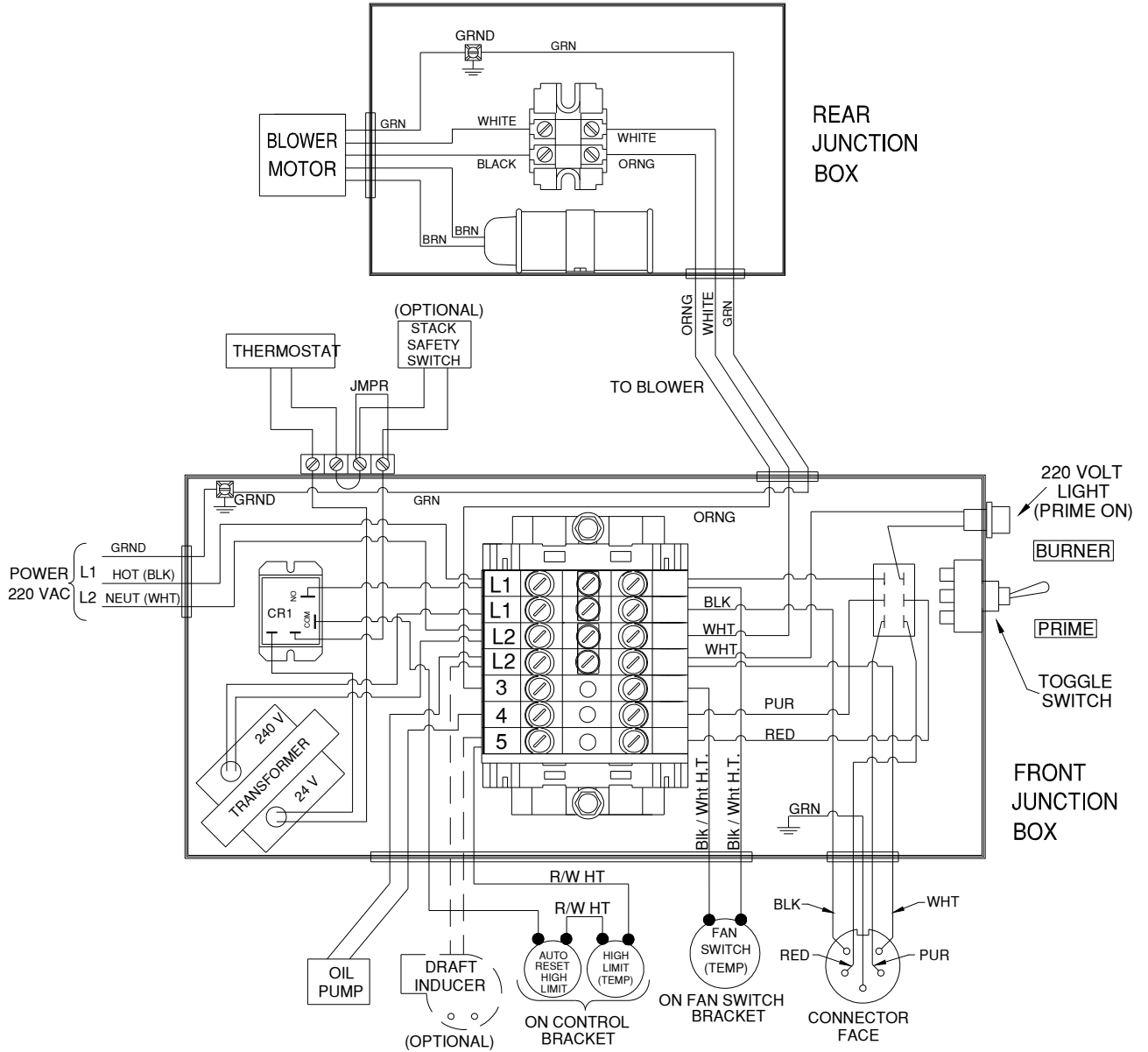

44115

Figure B1 - Furnace Wiring Diagram (CB-1500 & CB-2500)

Wiring Diagrams (continued)

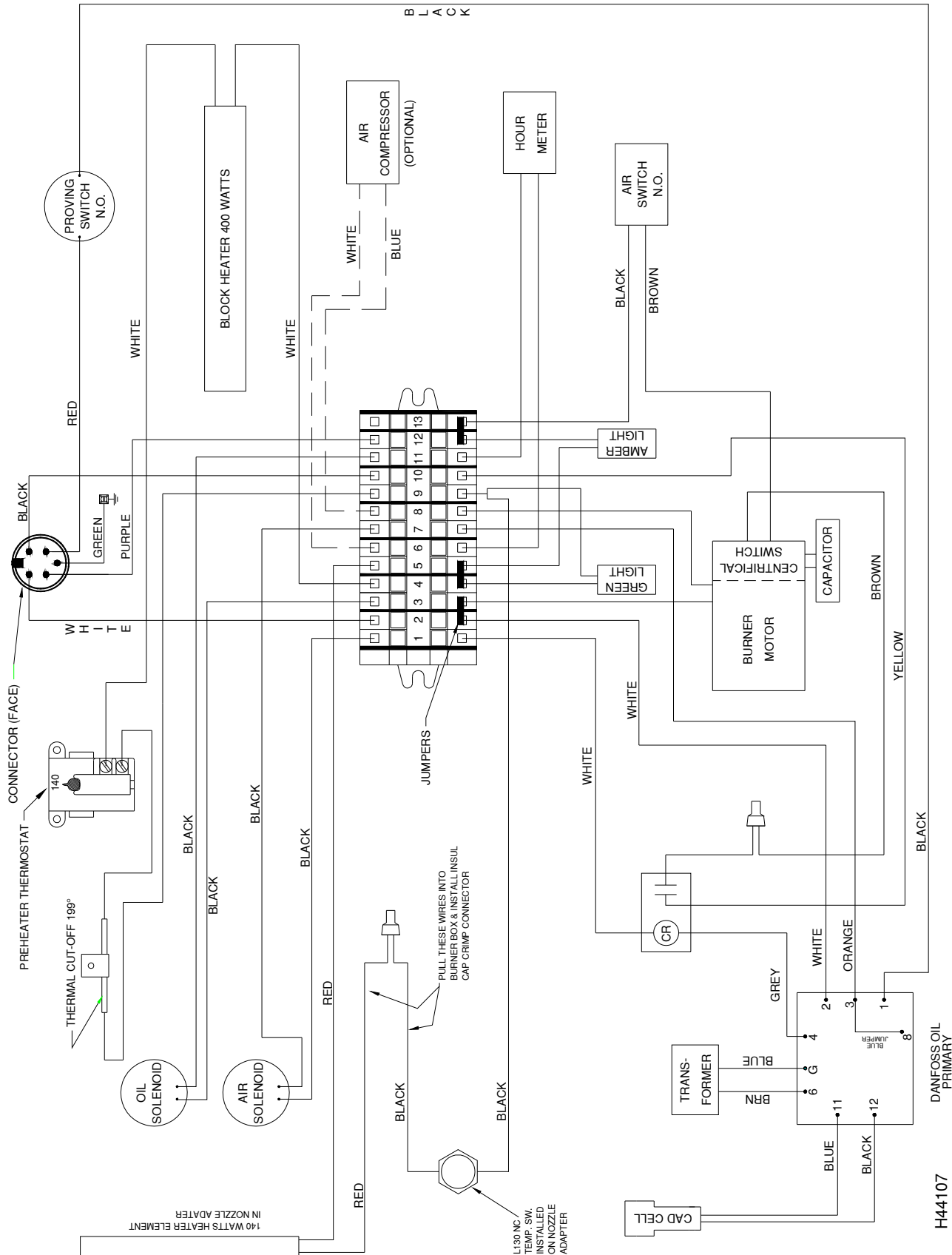
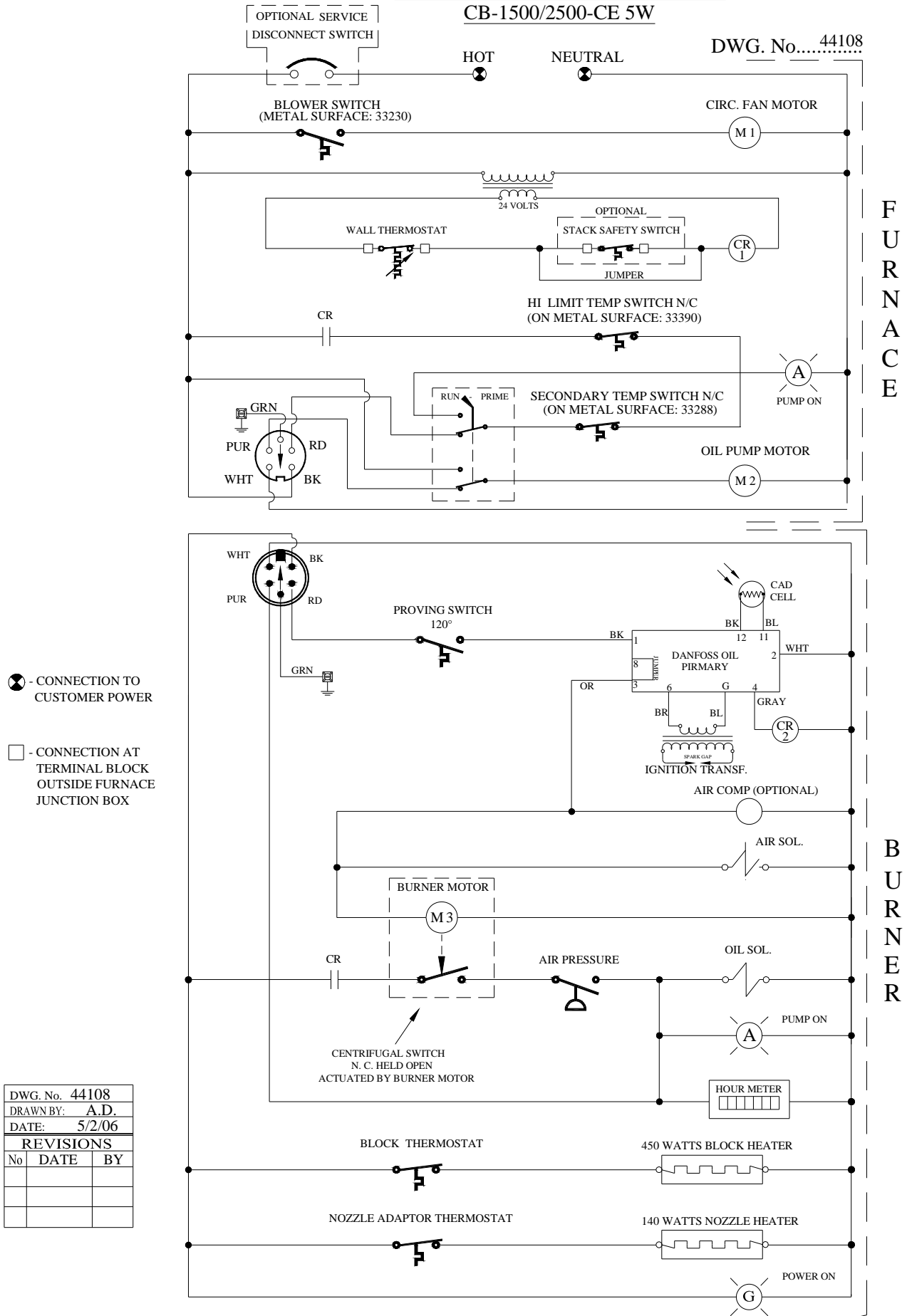

Figure B2 - Burner Wiring Diagram

FURNACE & BURNER SCHEMATIC

CB-1500/2500-CE 5W

DWG. No. 44108



DWG. No. 44108
 DRAWN BY: A.D.
 DATE: 5/2/06

REVISIONS		
No	DATE	BY

Figure B3 - Ladder Schematic for CB-1500 & CB-2500 Furnaces

Wiring Diagrams (continued)

230 V 50Hz POWER FROM OIL PUMP CIRCUIT
(SEE FURNACE SCHEMATIC)

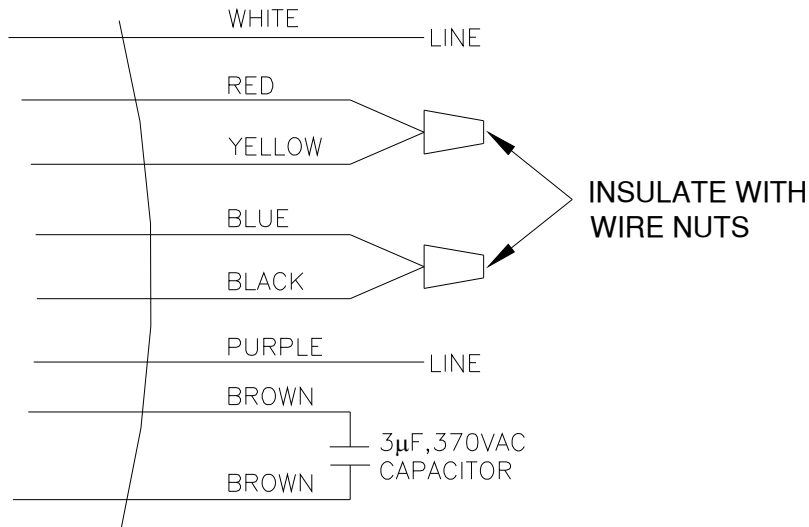

GEARMOTOR ROTATION IS CCWSE AS SHOWN. TO REVERSE ROTATION, REVERSE RED & BLUE LEADS

188524

Figure B4 - CB-1500 Metering Pump Wiring Schematic

230 V 50Hz POWER FROM OIL PUMP CIRCUIT
(SEE FURNACE SCHEMATIC)

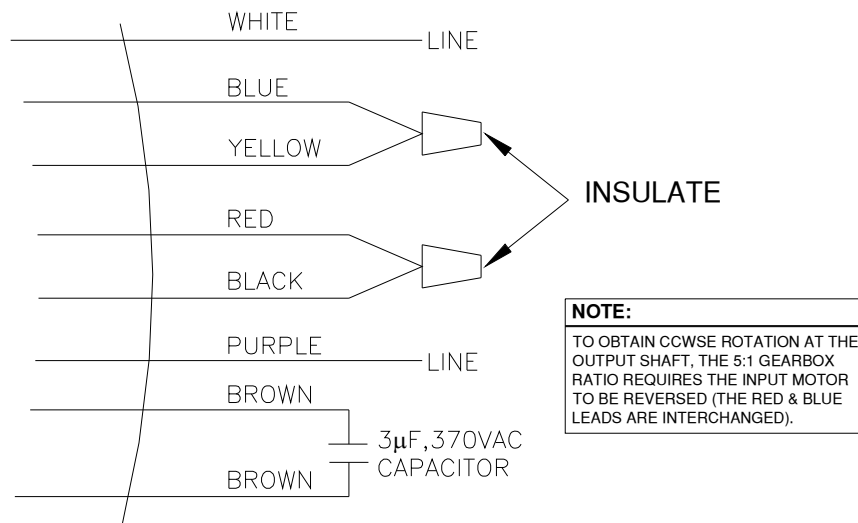

GEARMOTOR ROTATION IS CCWSE AS SHOWN. TO REVERSE ROTATION, REVERSE RED & BLUE LEADS

188525

Figure B5 - CB-2500 Metering Pump Wiring Schematic

APPENDIX C

Additional Installation and Maintenance Requirements

The following activities must also be accomplished for furnace installations in the United Kingdom:

- Installing a cover over the oil/air regulators on the burner
- Installing a fire valve above the burner

Instructions and/or drawings for these activities are provided in this Appendix.

Installing a Cover over the Oil/Air Regulators

A cover (C.B. #31185) must be placed over the oil and air regulator to prevent unauthorized adjustment after the equipment has been commissioned by qualified personnel (Figure C1).

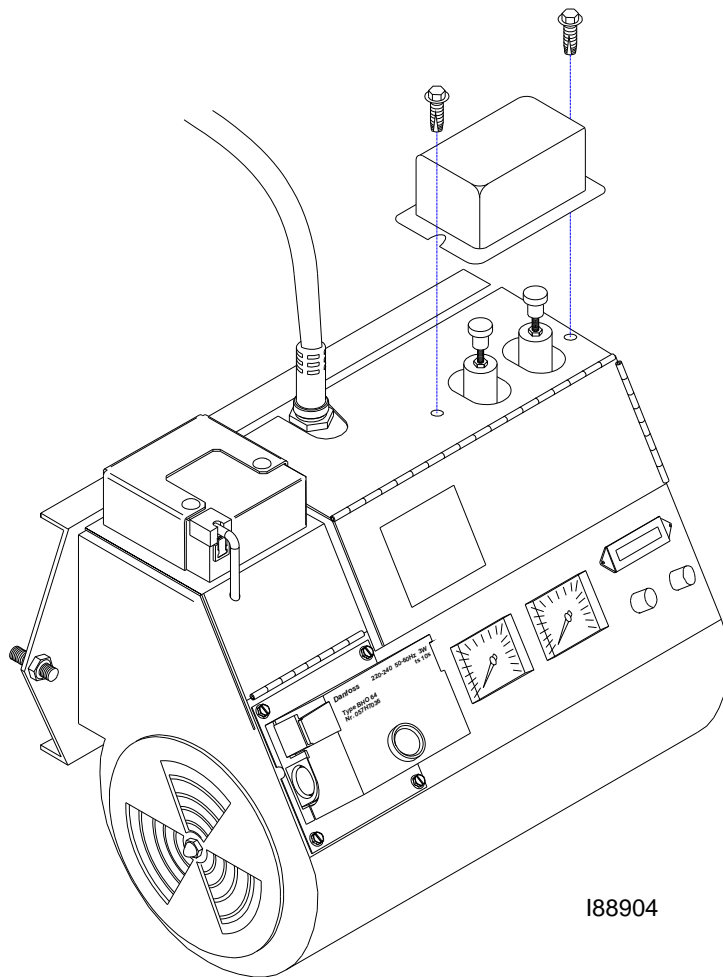

Figure C1 - Installing a Cover over the Oil/Air Regulators on the Burner

Installing a Fire Valve

Install a fire valve element in a position above the burner as shown in Figure C2 to provide adequate protection in accordance with BS 5410 Parts 1 and 2.

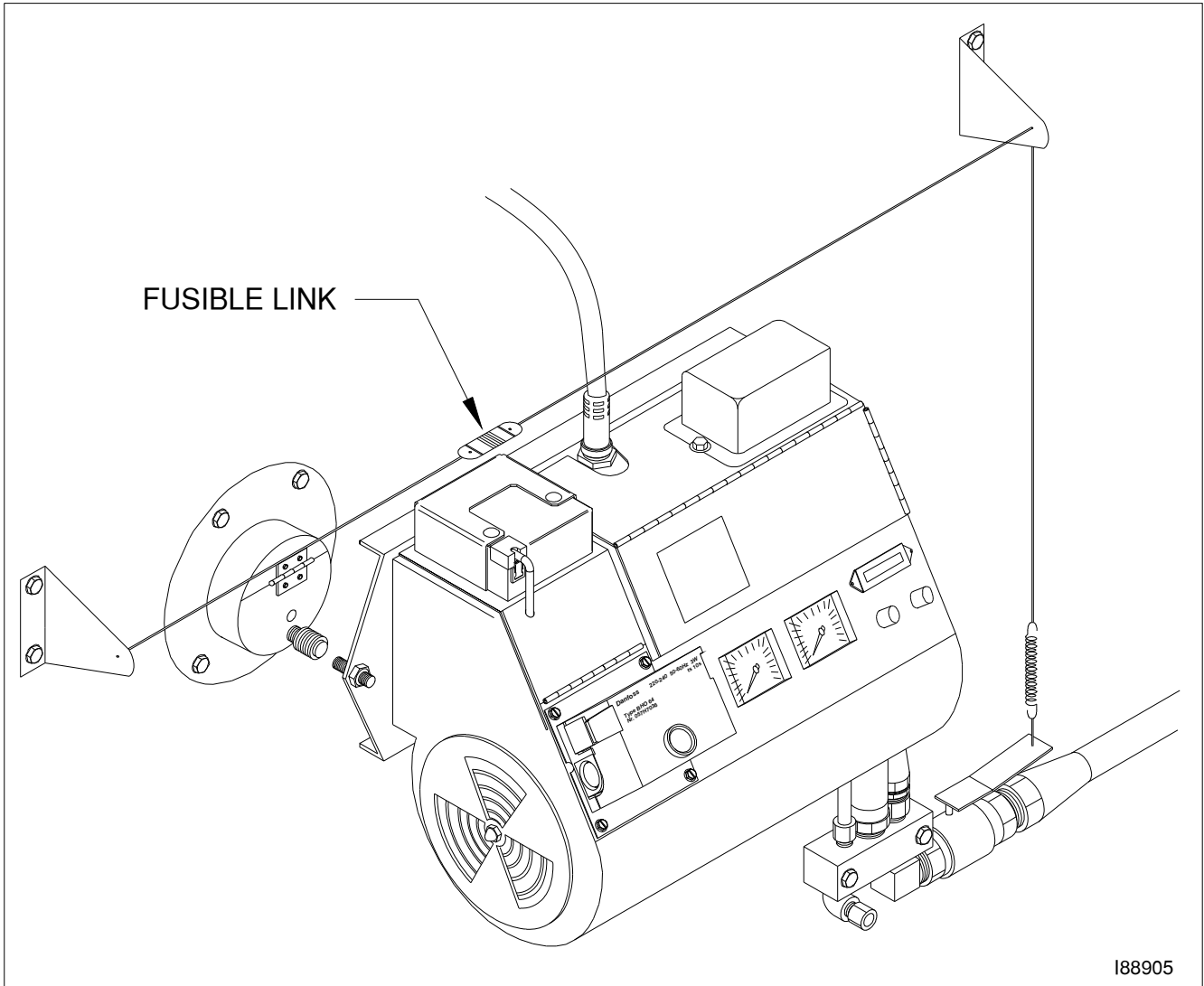

Figure C2 - Installation of a Fire Valve

APPENDIX D

Furnace Service Record

Furnace Purchased: Date _____ From (name/phone) _____

Furnace Installed: Date _____ By (name/phone) _____

Furnace Inspected: Date _____ By (name/phone) _____

Note: Refer to Section 9 for Maintenance Instructions

<u>Draft Readings</u> (Date / Draft)		<u>Service Record</u> (Date / Initials of Technician)						
Burner	Stack	Canister Filter	Metering Pump	Check Valve and Screen	Chamber & Flues	Stack	Oil Tank	A.P.M.*

*A.P.M. is Annual Preventative Maintenance on the Burner (Burner Tune-up)

