



OPERATOR'S MANUAL

CLEAN BURN MODELS:

CB-200-CTB COIL TUBE BOILER *with CB-525-S2 Burner & Metering Pump*

CB-350-CTB COIL TUBE BOILER *with CB-551-H3 Burner & Metering Pump*

CB-500-CTB COIL TUBE BOILER *with CB-551-H5 Burner & Metering Pump*

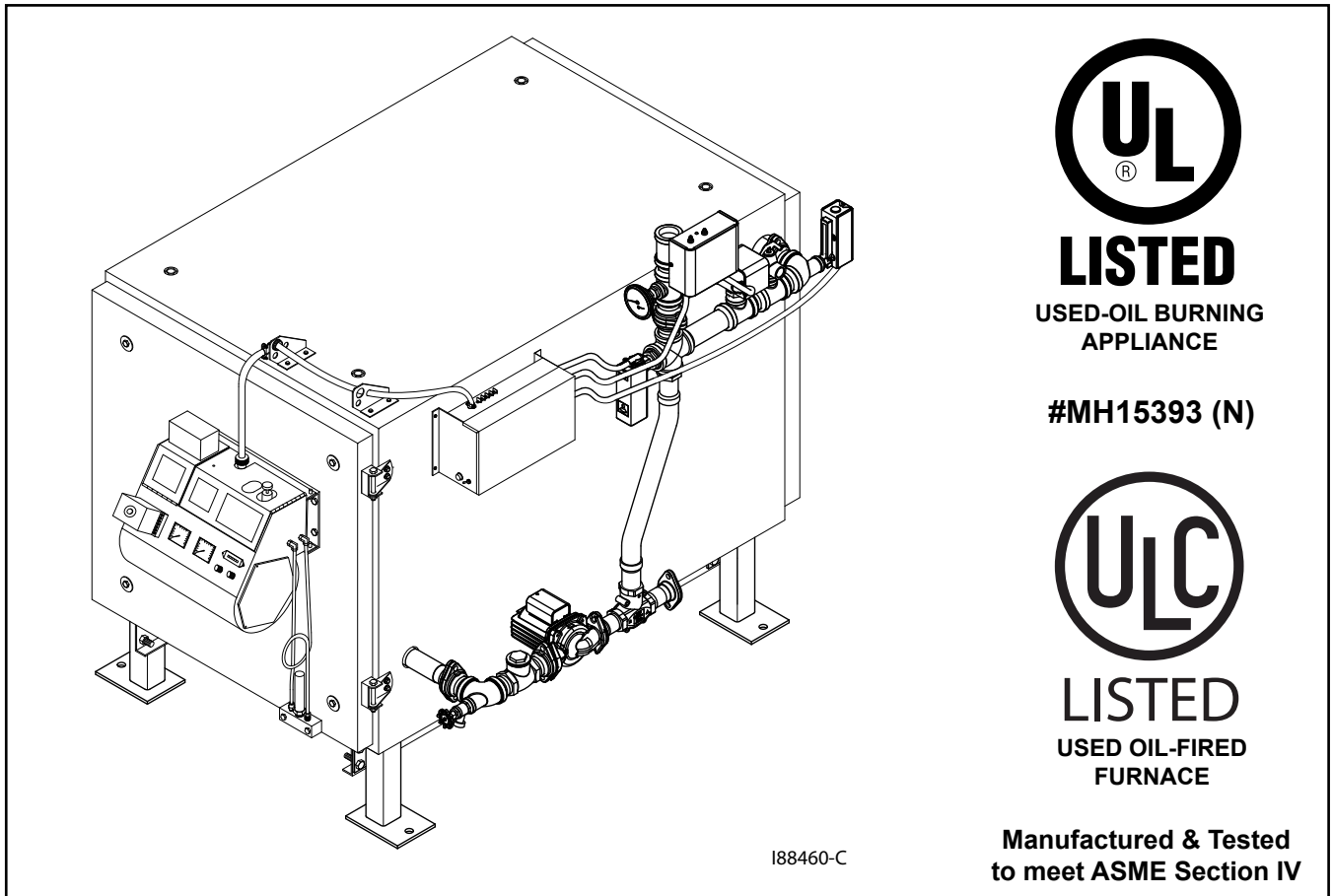

PUBLICATION DATE: 07/16/13, Rev. 13

CLEAN BURN PART #43146



WARNING: DO NOT assemble, install, operate, or maintain this equipment without first reading and understanding the information provided in this manual. Installation and service must be accomplished by qualified personnel. Failure to follow all safety precautions and procedures as stated in this manual may result in property damage, serious personal injury or death.

IMPORTANT FOR U.S. INSTALLATIONS: All installations must be made in accordance with state and local codes which may differ from the information provided in this manual. Save these instructions for reference.

IMPORTANT FOR CANADIAN INSTALLATIONS: The installation of this equipment is to be accomplished by qualified personnel and in accordance with the regulation of authorities having jurisdiction and CSA Standard B 139, Installation Code for Oil Burning Equipment.

WARRANTY INFORMATION

Clean Burn, LLC., MANUFACTURER, hereby warrants that MANUFACTURER's products shall be free from defect in material and workmanship under normal use according to the provisions and limitations herein set forth. MANUFACTURER warrants the burner and Coil Tube Boiler for a period of one (1) year from the date of purchase by the original purchaser. The steel coil tube section of the boiler only shall carry a limited warranty for a period of five (5) years from the date of purchase by the original purchaser.

LIMITATIONS:

The obligation of MANUFACTURER for breach of warranty shall be limited to products manufactured by MANUFACTURER (1) that are installed, operated and maintained according to MANUFACTURER's instructions furnished and/or available to the purchaser upon request; (2) that are installed according to all other applicable Federal, State and local codes or regulations; and (3) that the purchaser substantiates were defective in material and workmanship notwithstanding that they were properly installed and correctly maintained as set forth above and were not abused or misused.

The obligation of MANUFACTURER shall be limited to replacing or repairing the defective product, at the option of the MANUFACTURER. MANUFACTURER shall not be responsible for any labor or costs of removal or reinstallation of its products and shall not be liable for transportation costs to and from its plant at Lancaster, Pennsylvania.

Use of parts for modification or repair of the product or any component part thereof not authorized or manufactured by MANUFACTURER specifically for such product shall void this warranty.

This warranty shall not apply to any damage to or defect in any of MANUFACTURER's products that is directly or indirectly caused by (1) *force majeure*, Act of God or other accident not related to an inherent product defect; or (2) abuse, misuse or neglect of such product, including any damage caused by improper assembly, installation, adjustment, service, maintenance or faulty instruction of the purchaser.

Other than as expressly set forth hereinabove, MANUFACTURER makes no other warranty, express or implied, with respect to any of MANUFACTURER's products, including but not limited to any warranty of merchantability or fitness for a particular purpose.

And in no event shall MANUFACTURER be responsible for any incidental or consequential damages of any nature suffered by purchaser or any other person or entity caused in whole or in part by any defect in any of MANUFACTURER's products. Any person or entity to whom this warranty extends and who claims breach of warranty against MANUFACTURER must bring suit thereon within one year from the date of occurrence of such breach of warranty or be forever barred from any and all legal or other remedies for such breach of warranty.

MANUFACTURER is not responsible for and hereby disclaims any undertaking, representation or warranty made by any dealer, distributor or other person that is inconsistent with or in any way more expansive than the provisions of this limited warranty.

This warranty grants specific legal rights and shall be read in conformity with applicable state law. In some jurisdictions, the applicable law mandates warranty provisions that provide greater legal rights than those provided for herein. In such case, this limited warranty shall be read to include such mandated provisions; and any provision herein that is prohibited or unenforceable in any such jurisdiction shall, as to such jurisdiction, be ineffective to the extent of such prohibition or unenforceability without invalidating the remaining provisions and without affecting the validity or enforceability of such provision in any other jurisdiction(s).

TRADEMARKS

The Clean Burn logo is a trademark of Clean Burn, LLC. All other brand or product names mentioned are the registered trademarks or trademarks of their respective owners.

COPYRIGHT

Copyright © 2010 Clean Burn, LLC. All rights reserved. No part of this publication may be reproduced, or distributed without the prior written permission of Clean Burn, LLC. 4109 Capital Circle, Janesville WI 53546. Subject to change without notice.

TABLE OF CONTENTS

SECTION 1: INTRODUCTION	1-1
Guide to this Manual	1-1
For Your Safety.....	1-2
Guidelines for CTB Usage.....	1-4
Guidelines for Used Oil Tanks.....	1-5
Safety Labels.....	1-6
SECTION 2: UNPACKING & PRE-INSTALLATION CONSIDERATIONS	2-1
Removing the Shipping Crate	2-1
Unpacking and Inspection	2-1
CTB Component List.....	2-1
Warranty Registration.....	2-2
Pre-Installation Considerations	2-2
Determining the CTB System Setup.....	2-2
Selecting a Location.....	2-2
SECTION 3: COIL TUBE BOILER ASSEMBLY 3-1	
Understanding Assembly.....	3-1
Single Boiler Assembly Component Detail.....	3-2
Single Boiler Assembly	3-4
Installing the CTB on the Support Stand	3-4
Dual-Stacked Boiler Assembly.....	3-5
Assembling the Dual-Stacked Boiler.....	3-5
Assembly for All Boilers	3-8
Connecting the CTB.....	3-8
Installing the Ceramic Sleeve	3-9
Checking the Burner Nozzle and electrodes	3-11
Mounting the Burner.....	3-12
Installing the Connector Block	3-12
Installing the Oil Line Tubing.....	3-13
Installing the Air Line Tubing.....	3-14
Locking the Burner into Firing Position	3-14
SECTION 4: COIL TUBE BOILER INSTALLATION	4-1
Understanding Installation.....	4-1
Typical Installation Diagrams	4-2
Combustion Air Requirements.....	4-4
Oil Tank Installation Specifications.....	4-6
Installing the Tank Vent and Emergency Vent	4-7
Installing the Metering Pump	4-8
Preparing for Installation	4-8
Standard Mounting: Vertical Positioning.....	4-8
Alternate Mounting: Horizontal Positioning.....	4-10
Connecting Water to the Coil Tube Boiler	4-11
Filling the CTB with Water.....	4-11
Installing the Suction Oil Line Components	4-12

TABLE OF CONTENTS

SECTION 4: CTB INSTALLATION (continued)	
Installing the Pressure Relief Oil Line Back to the Tank	4-15
Installing the Pressure Oil Line Components	4-16
Installing the Compressed Air Line	4-16
Wiring the Coil Tube Boiler	4-17
Wiring to the Oil Pump	4-18
Wiring the Load Loop Circulator	4-18
Installing the Stack	4-19
Installing the Interior Stack	4-20
Installing the Barometric Damper	4-21
Installing the Stack Safety Switch For Canadian Installations	4-23
Resetting the Stack Safety Switch	4-24
Understanding the Function of the Stack Safety Switch	4-24
Installing the Stack Penetration	4-25
Installing the Exterior Stack	4-25
Installing the Stack Cap	4-25
Installing the Draft Inducer	4-25
Installing the Wall Thermostat	4-27
Replacing the Wall Thermostat Batteries	4-27
Inspecting the CTB Installation	4-28
SECTION 5: METERING PUMP PRIMING	5-1
Understanding Metering Pump Priming	5-1
Required Tools and Materials	5-1
Priming the Metering Pump	5-2
Vacuum Testing the Oil Pump	5-4
SECTION 6: STARTING AND ADJUSTING THE BURNER	6-1
Understanding Burner Startup and Adjustment 6-1	
Preparing the Hydronics System for Burner Startup	6-1
Preparing the Burner for Startup	6-1
Starting the Burner	6-3
SECTION 7: RESETTING THE OIL PRIMARY CONTROL	7-1
Understanding the Oil Primary Control	7-1
Resetting the Oil Primary Control (CB-200-CTB)	7-1
Resetting the Oil Primary Control (CB-350-CTB and CB-500-CTB)	7-2
Primary Control Operation/Troubleshooting Guide (CB-350-CTB and CB-500-CTB)	7-4
SECTION 8: ADJUSTING THE DRAFT OVER FIRE	8-1
Understanding the Importance of Draft	8-1
Checking for Correct Draft Over Fire	8-1
Understanding the Effect of Exhaust Fans on Draft	8-2
Checking Draft Over Fire to Determine Severity of Backdraft	8-2
Combustion Air Requirements	8-3
Adjusting Draft Over Fire With A Draft Inducer Installed	8-3
Air for Combustion and Ventilation	8-4

TABLE OF CONTENTS

SECTION 9: MAINTENANCE	9-1
Understanding Maintenance.....	9-1
Annual Preventative Maintenance & Burner Tune-up.....	9-1
Cleaning the Canister Filter.....	9-2
Servicing the Metering Pump.....	9-3
Cleaning the Check Valve.....	9-3
Cleaning Ash from the CTB.....	9-4
Cleaning the Oil Tank.....	9-6
End of Season Maintenance.....	9-6
Cleaning and Maintaining the Draft Inducer.....	9-6
SECTION 10: THE CTB HYDRONIC SYSTEM	10-1
Understanding the CTB Hydronic System.....	10-1
Special Safety Guidelines.....	10-1
CTB System Function and Configuration.....	10-2
CTB Setup Options.....	10-4
Guidelines for CTB Setup and Operation.....	10-7
Guidelines for Preventing Oxygen Contamination.....	10-8
Guidelines for Initial Cleaning and Maintaining Water Quality.....	10-8
Guidelines for CTB Operation.....	10-8
SECTION 11: TROUBLESHOOTING	11-1
Flow Chart.....	11-2
Troubleshooting Tables.....	11-3
APPENDIX A	
Detailed CTB Specifications.....	A-1
CTB Technical Specifications.....	A-1
Burner Technical Specifications.....	A-2
CTB Hydronic Specifications.....	A-2
CTB Accessories and Parts Reference.....	A-3
CTB Dimensions.....	A-4
Single Boiler Assembly Component Detail.....	A-10
Burner Components.....	A-12
CB-525-S2 (CB-200-CTB).....	A-12
CB-551-H3 (CB-350-CTB).....	A-14
CB-551-H5 (CB-500-CTB).....	A-18
Removing the Nozzle for cleaning.....	A-23
CB-200-CTB Components.....	A-24
CB-350-CTB Components.....	A-26
CB-500-CTB Components.....	A-28
Metering Pump Components.....	A-30
APPENDIX B	
Wiring Diagrams.....	B-1
CTB Sequence of Operation.....	B-4
CTB Ladder Schematic.....	B-5
Metering Pump Wiring Schematic.....	B-6
CAD Cell Oil Primary Control Data Sheets.....	B-7

TABLE OF CONTENTS

APPENDIX C

CTB Service Record.....	C-1
-------------------------	-----

SECTION 1: INTRODUCTION

Guide to this Manual

This manual contains all the information necessary to safely install and operate the Clean Burn Coil Tube Boilers (CTB), Model CB-200-CTB, CB-350-CTB, and CB-500-CTB. Consult the Table of Contents for a detailed list of topics covered. You'll find this manual's step-by-step procedures easy to follow and understand. Should questions arise, please contact your Clean Burn dealer before starting any of the procedures in this manual.

As you follow the directions in this manual, you'll discover that assembling and operating the Clean Burn CTB involves six basic activities as outlined here:

- **UNPACKING & PRE-INSTALLATION CONSIDERATIONS** (Section 2)
- **ASSEMBLY** (Section 3)
- **INSTALLATION** (Section 4)
- **OPERATION**
 - **Oil Pump Priming** (Section 5)
 - **Starting and Adjusting the Burner** (Section 6)
 - **Resetting the Oil Primary Control** (Section 7)
 - **Adjusting the Draft** (Section 8)
- **MAINTENANCE** (Section 9)
- **THE CTB HYDRONICS SYSTEM** (Section 10)

The manual also contains important and detailed technical reference materials which are located at the back of the manual in the Appendixes.

Please read all sections carefully--including the following safety information--before beginning any installation/operation procedures; doing so ensures your safety and the optimal performance of your Clean Burn Coil Tube Boiler

WARNING!



STOP

**YOUR SAFETY IS AT STAKE!
DO NOT INSTALL, OPERATE OR
MAINTAIN THIS EQUIPMENT
WITHOUT FIRST READING
AND UNDERSTANDING THE
OPERATOR'S MANUAL!**

For Your Safety...

For your safety, Clean Burn documentation contains the following types of safety statements (listed here in order of increasing intensity):

- **NOTE:** A clarification of previous information or additional pertinent information.
- **ATTENTION:** A safety statement indicating that potential equipment damage may occur if instructions are not followed.



CAUTION: A safety statement that reminds of safety practices or directs attention to unsafe practices which could result in personal injury if proper precautions are not taken.



WARNING: A *strong* safety statement indicating that a hazard exists which can result in injury or death if proper precautions are not taken.



DANGER! *The utmost levels of safety must be observed;* an extreme hazard exists which would result in high probability of death or irreparable serious personal injury if proper precautions are not taken.

In addition to observing the specific precautions listed throughout the manual, **the following general precautions apply and *must be heeded to ensure proper, safe boiler operation.***



DANGER! DO NOT create a fire or explosion hazard by storing or using gasoline or other flammable or explosive liquids or vapors near your boiler.



DANGER! DO NOT operate your CTB if excess oil, oil vapor or fumes have accumulated in or near your boiler. As with any oil burning appliance, improper installation, operation or maintenance may result in a fire or explosion hazard.



WARNING: DO NOT add inappropriate or hazardous materials to your used oil, such as:

- Anti-freeze
- Carburetor cleaner
- Paint thinner
- Parts washer solvents
- Gasoline
- Oil additives
- Any other inappropriate/hazardous material



WARNING: Burning chlorinated materials (chlorinated solvents and oils) is *illegal*, will *severely damage* your heat exchanger, immediately *void* your warranty, and adversely affect the proper, safe operation of your CTB. Instruct your personnel to *never* add hazardous materials to your used oil.

For Your Safety... (continued)



WARNING: Never alter or modify your CTB without prior written consent of Clean Burn, LLC. Unauthorized modifications or alteration can adversely affect the proper, safe operation of your boiler.



WARNING: The burner which is shipped with your Clean Burn CTB is to be used *only* with your boiler according to the instructions provided in this manual. **DO NOT** use the burner for any other purpose!



WARNING: *The Best Operator is a Careful Operator!* By using common sense, observing general safety rules, and adhering to the precautions specific to the equipment, you, the operator, can promote safe equipment operation. ***Failure to use common sense, observe general safety rules, and adhere to the precautions specific to the equipment may result in equipment damage, fire, explosion, personal injury and/or death.***



WARNING: The installation, operation, and maintenance of this equipment must be accomplished by qualified personnel and in compliance with the specifications in the Clean Burn Operator's Manual and with all national, state, and local codes or authorities having jurisdiction over environmental control, building inspection and fuel, fire and electrical safety and the following standards:

ASME Section IV	Boiler Code for Pressure Vessels
ASME CSD-1	Controls and Safety Devices for Automatically Fired Boilers
NFPA 30	Flammable and Combustible Liquids Code
NFPA 30A	Automotive and Marine Service Station Code
NFPA 31	Standard for the Installation of Oil Burning Equipment
NFPA 70	National Electrical Code
NFPA 88A	Parking Structures
NFPA 88B	Repair Garages
NFPA 211	Chimneys, Fireplaces, Vents and Solid Fuel Burning Appliances
The International Mechanical Code	
The International Building Code	
The International Fire Code	
The International Fuel Gas Code	

Likewise, the installation, operation, and maintenance of this equipment in **Canada** is to be accomplished by qualified personnel and in compliance with the specifications in the Clean Burn Operator's Manual and in accordance with the regulation of authorities having jurisdiction and the following CSA Standards:

B139	Installation Code for Oil Burning Equipment
B140.0	General Requirements for Oil Burning Equipment
B140.7.2	Oil-Fired Steam and Hot Water Boilers for Commercial and Industrial Use
B214	Installation Code for Hydronic Heating Systems
C22.1	Canadian Electrical Code, Part 1.

Failure to comply with these standards and requirements may result in equipment damage, fire, explosion, personal injury and/or death.

For Your Safety... (continued)

Guidelines for Coil Tube Boiler Usage

- This boiler is listed for commercial and/or industrial use only; it is *not* listed for residential use.
- This boiler is listed with Underwriters Laboratory (UL) to burn the following fuels:
 - Used crankcase oil up to 50 SAE
 - Used transmission fluid (for U.S.)
 - Used hydraulic oils
 - #2, #4, and #5 fuel oils

NOTE: Used oils may contain other substances, including gasoline, that may hinder performance.

- Make sure you comply with all EPA regulations concerning the use of your boiler. EPA regulations require that:
 - Your used oil is generated on-site. You may also accept used oil from "do-it-yourself" oil changers.
 - Hazardous wastes, such as chlorinated solvents, are NOT to be mixed with your used oil.
 - The flue gases are vented to the outdoors with an appropriate stack.
 - Your used oil is recycled as fuel for "heat recovery". DO NOT operate your boiler in warm weather just to burn oil.

Contact your Clean Burn dealer for current EPA regulations.





- If your CTB ever requires service, call your Clean Burn dealer. DO NOT allow untrained, unauthorized personnel to service your CTB. Make sure that your boiler receives annual preventative maintenance to ensure optimal performance.

For Your Safety... (continued)

Guidelines for Used Oil Tanks

For the safe storage of used oil and the safety of persons in the vicinity of the used oil supply tank, ensure that your tank installation adheres to the following safety guidelines:

- **The tank installation must meet all national and local codes.** Consult your local municipal authorities for more information as necessary.
- **Review and adhere to the safety guidelines for used oil supply tanks as stated in the WARNING shown.**
- Ensure that the tank for your boiler installation complies with all code and safety requirements as stated here. If the tank does not comply, DO NOT use it.
- If you do not have a copy of the tank safety label pictured at right, please contact your Clean Burn dealer for the label, which is to be affixed directly on your used oil supply tank.

 WARNING	
	
Fire and explosion hazards To prevent serious injury or death:	
<p>ONLY place these listed substances in this used-oil supply tank:</p> <ul style="list-style-type: none"> • Used crankcase oil • Used automatic transmission fluid • Used hydraulic oil • #2 fuel oil <p>Do NOT place flammable or corrosive substances such as gasoline, chlorinated oils, solvents, paint thinners, or any other unsafe substances in this used-oil supply tank.</p>	
<p>Do NOT weld or allow open flame within 35 feet of this used-oil supply tank.</p>	
<p>Tank installation MUST comply with NFPA 30 and 31 Fire Codes, including the following requirements:</p> <ul style="list-style-type: none"> • Tank must be listed to UL 80 or UL 142. • Tank must be vented to outside. • Emergency vent or explosion relief must be installed on tank. • Inside fill allowed only with funnel including 1/4 turn-to-close fall valve, which must be closed after filling. • All other openings must be plugged • All oil lines must be constructed of copper, steel, or brass components. Do NOT use rubber or plastic tubing or piping, or any other inappropriate material. 	
	<p>Follow all instructions for tank installation in Operator's Manual.</p>

42366 Rev. 2

For Your Safety... (continued)

Safety Labels

Following are the locations and descriptions of all labels on your CTB. The following illustrations show the location of ALL labels on your boiler. Please note that some labels denote model number, model description, etc. while others contain important safety messages.

Each **Safety Label** contains an important safety message starting with a key word as discussed earlier in this section (e.g. ATTENTION, CAUTION, WARNING, DANGER). For your safety and the safe operation of your CTB, review all labels and heed all safety messages as printed on the labels.

If any labels on your Clean Burn CTB ever become worn, lost or painted over, please call your Clean Burn dealer for free replacements.

CTB Cabinet Labels

<u>200-CTB</u>	<u>350-CTB</u>	<u>500-CTB</u>	<u>Description</u>
42367	42367	42367	C.B. Safety Warning Label (multiple messages - fire/shock/burn hazards)
42457	42457	42457	Made in USA / Patent Pending Combination Label
42027	42027	42027	Burn Hazard / Hazardous Voltage Warning Label
42358	42358	42358	UL Header Label
42464	42288	42496	CTB Data Label
42030	42030	42030	Electrical Shock Hazard Warning Label
42421	42421	42421	CTB Hot Water Caution Label
42216	42497	42497	C.B. Logo Label
42465	42286	42493	CTB Model # Label

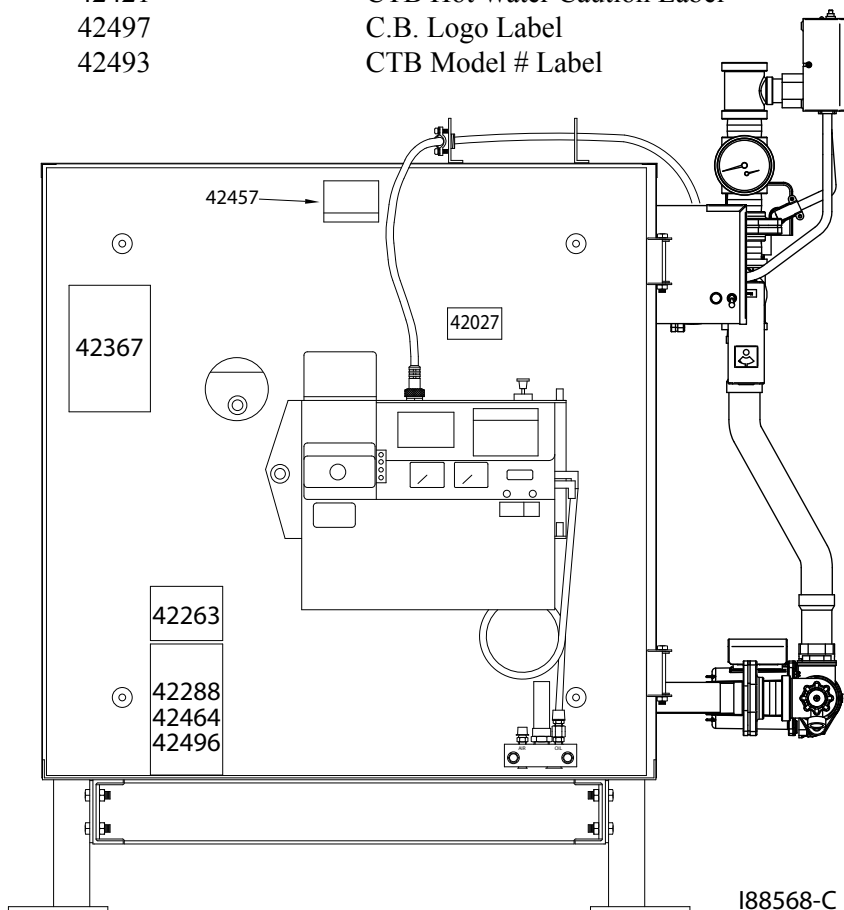

CTB Cabinet Labels (continued)

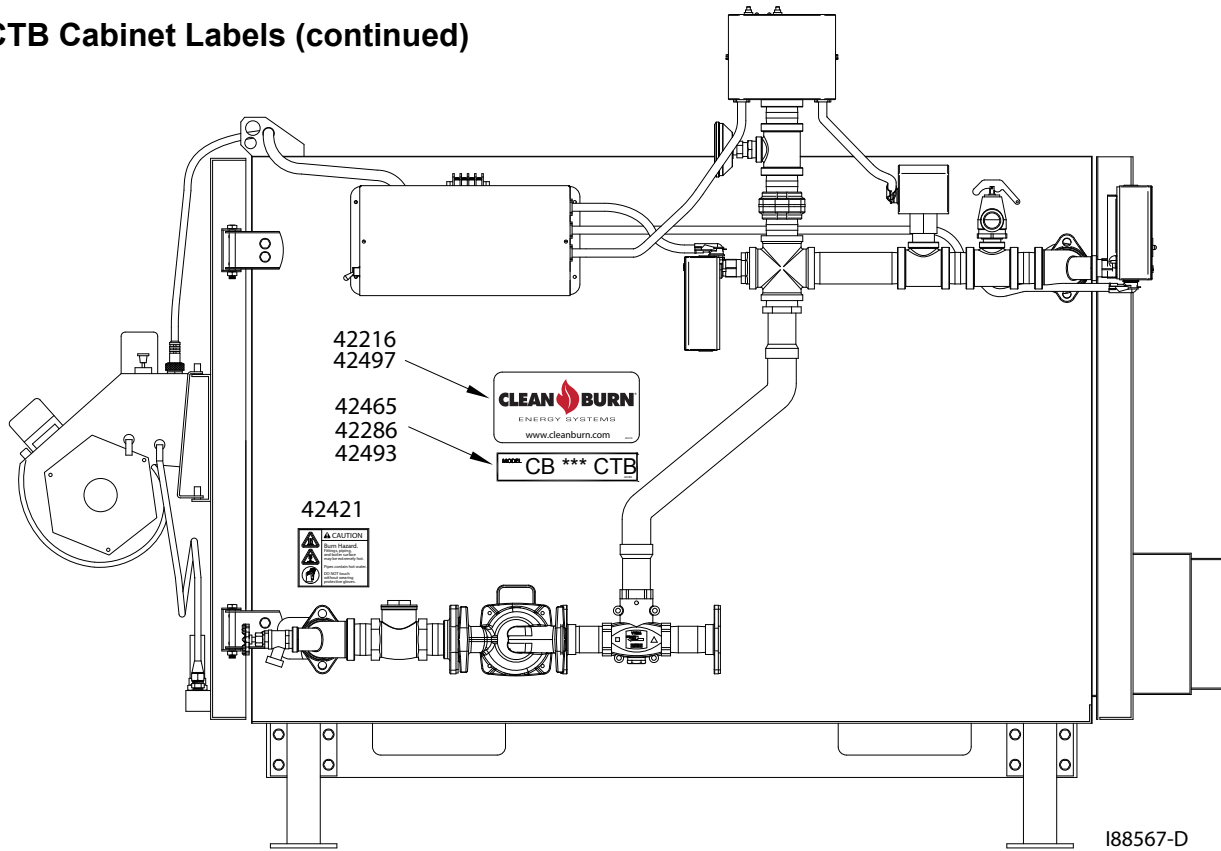

188567-D

CTB Cabinet Safety Labels

⚠ WARNING

Hazardous voltage.

To prevent serious injury, shut OFF main power to unit before removing cover.

Line voltage is present on most subbase terminals when power is ON. If the furnace is not wired correctly, fire, shock or damage could result.

- ONLY a qualified electrician should wire this furnace.
- ONLY use copper conductors.

42030 Rev. 2

⚠ WARNING

Fire, explosion and burn hazards:

Maintain clearances from combustibles as listed on unit. ONLY burn used crankcase oil, automatic transmission fluid, hydraulic oil, or #2 fuel oil. NEVER burn any other substances in this unit.

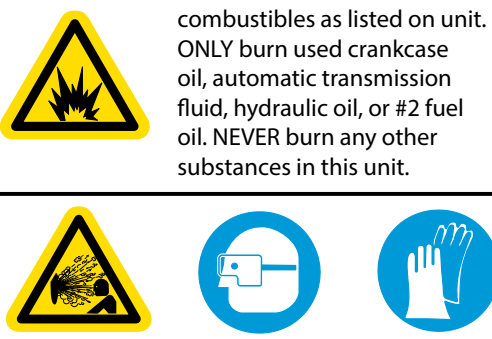

Hot gases and ash may be released when inspection port is opened.

- Wear safety goggles and hand protection when opening inspection port.
- Keep face away and open port slowly.

To avoid possible injury, death, or equipment damage, read and understand operator's manuals and all safety precautions before installing, operating, or servicing this equipment.

42367 Rev. 2

⚠ WARNING



Burn Hazard. Hazardous Voltage.

Burner may fire at any time. Disconnect burner power cord before swinging open burner or clean-out door.

42027 Rev. 2

For Your Safety... (continued)

CTB Cabinet Safety Labels (continued)

CAUTION

Burn Hazard.

Fittings, piping, and boiler surface may be extremely hot.

Pipes contain hot water.

Do NOT touch without wearing protective gloves.

42421

CLEAN BURN LLC
JANESVILLE, WISCONSIN (USA)

MH15393



LISTED

USED-OIL BURNING APPLIANCE



USED OIL-FIRED FURNACE
USED OIL-FIRED BOILER
For use with Integral Primary Safety Control

13084

MULTI-OIL HEATING SYSTEM

INSTALL AND USE ONLY IN ACCORDANCE WITH THE MFR'S INSTALLATION AND OPERATING INSTRUCTIONS. FOR COMMERCIAL OR INDUSTRIAL USE ONLY.

AUTHORITIES HAVING JURISDICTION SHOULD BE CONSULTED PRIOR TO INSTALLATION.

CERTIFIED TO ELECTRICAL AND FUEL BURNING REQUIREMENTS ONLY. 42358

MODEL NO.	CB-200 CTB		
INPUT RATING W/NO 2 FUEL OIL (BTU/HR)	200000		
LISTED FUELS	UL INPUT - GPH -	ATOM AIR PRESSURE - PSIG -	OIL PRESSURE - PSIG -
NO 2 OIL	1.4	14.0	2.5
USED CRANKCASE OIL	1.4	14.0	2.7
HYDRAULIC OIL	1.4	14.0	2.5
ATF	1.4	18.0	3.4
NO 4 OIL	1.4	18.0	4.0
NO 5 OIL	1.4	18.0	4.0

FLUE DRAFT IN W.C.		-06
INSTALL ON NONCOMBUSTIBLE FLOOR MINIMUM CLEARANCE TO COMBUSTIBLE SURFACES (IN.) CLEARANCES MAY BE INCREASED FOR SERVICE		
TOP	CHIMNEY	SIDE
18	18	6
FRONT	REAR	PLUMBING SIDE
48	6	30

	POWER	VOLTS	AMPS	HZ
OIL PUMP MOTOR HP.	1/20	120	.75	60
BURNER MOTOR HP.	1/10	120	1.4	60
BURNER HEATER WATTS	400	120	3.3	60
CIRCULATOR BOILER (OPT)	1/6	120	2.1	60
CIRCULATOR LOAD (OPT) MAX.		120	3.0	60
DRAFT INDUCER HP.	1/10	120	1.1	60
AIR COMPRESS. (OPT) HP.	1/3	120	4.0	60
TOTAL CIRCUIT AMPACITY			12.0	
MAXIMUM FUSE SIZE / WITH OPTIONS			15/20	

BURNER REQUIRES A MINIMUM AIR SOURCE OF 2 S.C.F.M. AT 25 P.S.I. INSTALL AND USE ONLY IN ACCORDANCE WITH THE MFR'S INSTALLATION AND OPERATING INSTRUCTIONS. FOR COMMERCIAL OR INDUSTRIAL USE ONLY.

AUTHORITIES HAVING JURISDICTION SHOULD BE CONSULTED PRIOR TO INSTALLATION

42464 - R1

MODEL NO.	CB-350 CTB		
INPUT RATING W/NO 2 FUEL OIL (BTU/HR)	350000		
LISTED FUELS	UL INPUT - GPH -	ATOM AIR PRESSURE - PSIG -	OIL PRESSURE - PSIG -
NO 2 OIL	2.5	16.0	6.0
USED CRANKCASE OIL	2.5	16.0	7.0
HYDRAULIC OIL	2.5	16.0	7.0
ATF	2.5	18.0	7.0
NO 4 OIL	2.5	20.0	9.5
NO 5 OIL	2.5	20.0	9.5

FLUE DRAFT IN W.C.		-06
INSTALL ON NONCOMBUSTIBLE FLOOR MINIMUM CLEARANCE TO COMBUSTIBLE SURFACES (IN.) CLEARANCES MAY BE INCREASED FOR SERVICE		
TOP	CHIMNEY	SIDE
18	18	6
FRONT	REAR	PLUMBING SIDE
48	6	30

	POWER	VOLTS	AMPS	HZ
OIL PUMP MOTOR HP.	1/20	120	.75	60
BURNER MOTOR HP.	1/10	120	1.4	60
BURNER HEATER WATTS	400	120	3.3	60
CIRCULATOR BOILER (OPT)	2/5	120	4.7	60
DRAFT INDUCER HP.	1/10	120	1.1	60
AIR COMPRESS. (OPT) HP.	1/2	120	5.8	60
TOTAL CIRCUIT AMPACITY			17	
MAXIMUM FUSE SIZE / WITH OPTIONS			20/30	

BURNER REQUIRES A MINIMUM AIR SOURCE OF 2 S.C.F.M. AT 25 P.S.I. INSTALL AND USE ONLY IN ACCORDANCE WITH THE MFR'S INSTALLATION AND OPERATING INSTRUCTIONS. FOR COMMERCIAL OR INDUSTRIAL USE ONLY.

AUTHORITIES HAVING JURISDICTION SHOULD BE CONSULTED PRIOR TO INSTALLATION

42288 - R1

For Your Safety... (continued)

CTB Cabinet Safety Labels (continued)

 NOTICE!
<p>PLUMBING ASSEMBLY IS SHIPPED DRY FIT ONLY.</p> <p>DO NOT INSTALL UNTIL PLUMBING COMPONENTS ARE RE-ASSEMBLED WITH PROPER THREAD SEALANT.</p>
I42325

MODEL NO.	CB-500 CTB		
INPUT RATING W/NO 2 FUEL OIL (BTU/HR)	500000		
LISTED FUELS	UL INPUT - GPH -	ATOM AIR PRESSURE - PSIG -	OIL PRESSURE - PSIG -
NO 2 OIL	3.57	18.0	2.1
USED CRANKCASE OIL	3.57	18.0	3.0
HYDRAULIC OIL	3.57	24.0	2.5
ATF	3.57	22.0	2.7
NO 4 OIL	3.57	18.0	3.0
NO 5 OIL	3.57	18.0	3.0

FLUE DRAFT IN W.C.			-06
INSTALL ON NONCOMBUSTIBLE FLOOR			
MINIMUM CLEARANCE TO COMBUSTIBLE SURFACES (IN.)			
CLEARANCES MAY BE INCREASED FOR SERVICE			
TOP	18	CHIMNEY	18
FRONT	48	REAR	6
		SIDE	6
		PLUMBING SIDE	30



	POWER	VOLTS	AMPS	HZ
OIL PUMP MOTOR HP.	1/20	120	.75	60
BURNER MOTOR HP.	1/10	120	1.4	60
BURNER HEATER WATTS	500	120	4.2	60
CIRCULATOR BOILER (OPT)	1/2	120	5.0	60
DRAFT INDUCER HP	1/3	120	3.9	60
AIR COMPRESS. (OPT) HP.	1/2	120	5.8	60
TOTAL CIRCUIT AMPACITY				21.0
MAXIMUM FUSE SIZE / WITH OPTIONS				30

BURNER REQUIRES A MINIMUM AIR SOURCE OF 2 S.C.F.M. AT 25 P.S.I. INSTALL AND USE ONLY IN ACCORDANCE WITH THE MFR'S INSTALLATION AND OPERATING INSTRUCTIONS. FOR COMMERCIAL OR INDUSTRIAL USE ONLY.

AUTHORITIES HAVING JURISDICTION SHOULD BE CONSULTED PRIOR TO INSTALLATION

42496 - R1

CTB Burner Safety Labels

	 WARNING
	<p>Fire and explosion hazard.</p> <p>This burner is to be installed ONLY on Clean Burn products.</p> <p>Only a qualified technician may maintain and service this burner.</p> <p style="text-align: right;">42235 Rev. 2</p>

For Your Safety... (continued)

CTB Burner Safety Labels (continued)

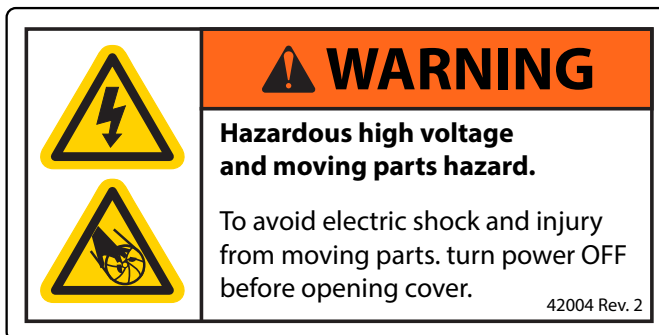

CTB Burner Labels

<u>200-CTB</u>	<u>350-CTB</u>	<u>500-CTB</u>	<u>Description</u>
42005	42005	42005	Sold/Service By Label
42004	42004	42004	Burner Safety Warning Label (High Voltage/Moving Parts Hazard)
42235	42235	42235	Burner Safety Warning Label (Fire/Explosion Hazard - Burner Installation and Service)
42321	42337	42494	Burner Model # Label
42229	42229	42229	C.B. Logo/Burner Description Label
42000	42000	42000	Burner Safety Warning Label (Fire/Explosion Hazard - Reset Button)
42023	42023	42023	Burner Power Label

TOPVIEW

FRONT VIEW

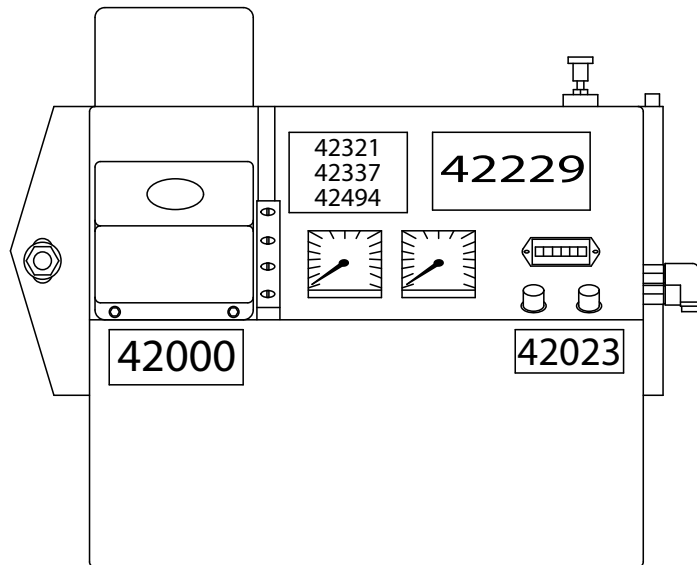
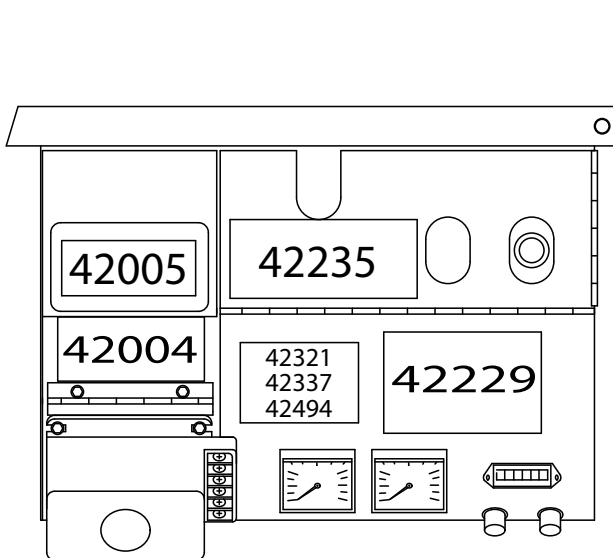

188722-B

For Your Safety... (continued)

Metering Pump Labels

<u>200-CTB</u>	<u>350-CTB</u>	<u>500-CTB</u>	<u>Description</u>
42284	42284	42284	Metering Pump Wiring Diagram
42466	42420	42495	Model Number / Warning

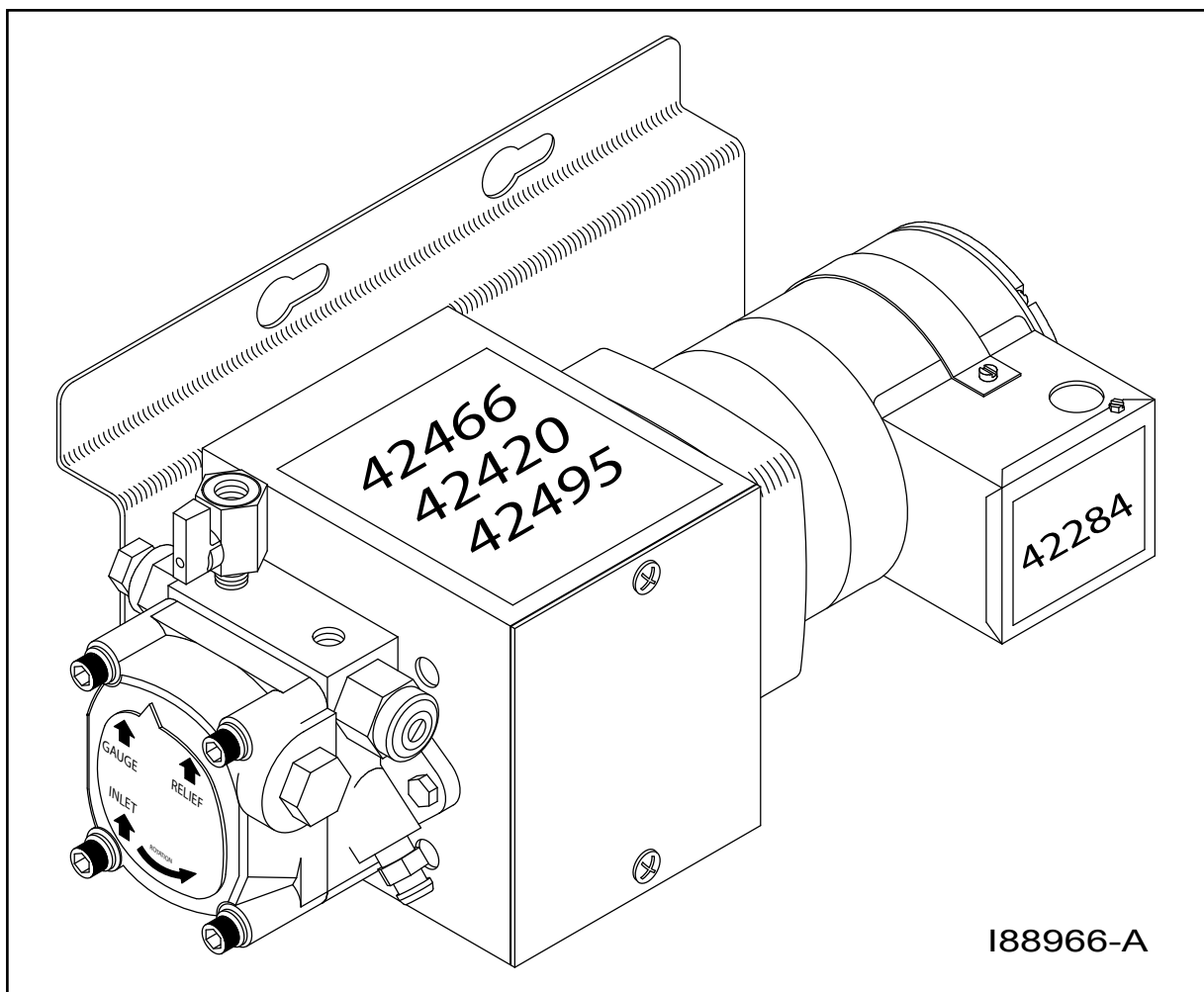

SECTION 2: UNPACKING & PRE-INSTALLATION CONSIDERATIONS

Before assembling your coil tube boiler (CTB) , you must accomplish the following activities described in this section:

- Removing the Shipping Crate
 - Unpacking and Inspecting All Components
 - Warranty Registration
 - Review the Pre-Installation Considerations
-

Removing the Shipping Crate

1. Carefully remove the top boards of the shipping crate. Then remove the front, back, and side panels.
2. Remove the bolts holding the boiler on the shipping pallet.
3. Carefully lift the CTB off the shipping pallet with a fork lift.

ATTENTION: DO NOT attempt to slide the CTB out of the shipping crate - you may damage the cabinet.

Unpacking and Inspection

Following is an itemized list of all components you should have received in your Clean Burn Coil Tube Boiler shipment. Open all shipping containers and inspect all components according to the list. Immediately notify the freight company and your Clean Burn dealer in case of shipping damage or shortage(s). Keep all components together so you will have them as needed for CTB assembly and installation.

CTB Component List

- Coil Tube Boiler with factory-installed controls
(including operating aquastat, high temperature cut-off, flow switch, relief valve, and check valve)
 - Components packed inside boiler:
 - Ceramic combustion chamber sleeve
 - Combustion chamber sleeve mounting stand
 - Ceramic target (pre-mounted)
 - Canister filter
 - Vacuum gauge
 - Check valve with screen (for tank)
 - Boiler gauge
 - Low water cut-off
 - Tube sealant
 - Burner hook-up kit
 - Barometric damper
 - Burner
 - Oil pump
 - CTB base stand with hardware
 - Draft Inducer
-

Warranty Registration

For proper warranty registration, Clean Burn requires that you fill out the provided warranty registration card and return it *within 30 days* to:

CLEAN BURN WARRANTY REGISTRATION

Clean Burn, LLC.
4109 Capital Circle
Janesville, WI 53546

Pre-Installation Considerations

The following information is critical to the proper installation of your Clean Burn Coil Tube Boiler system; read this section carefully before starting any other procedures.

Determining the CTB System Setup

Before installing the CTB, you must determine the following which relate to your installation:

- (1) The **type of oil storage tank** you will be using (related information in Section 4)**
- (2) The **positioning of your oil pump** (related information in Section 4)
- (3) The **appropriate size for your oil lines** (related information in Section 4)
- (4) The **electrical requirements** for your CTB installation (related information in Section 4)
- (5) The type of **hydronic installation** you will be using (related information in Section 10)

****IMPORTANT NOTE:** If you are installing an inside oil tank in the same room as the boiler, you must allow a 5 foot minimum clearance between the tank and the boiler. *The oil tank should be set and installed in position BEFORE the boiler is installed.*

Selecting a Location

The location you select for your CTB must allow the following:

- Installation on a substantial, level, non-combustible concrete floor (minimum 4" thick).
- Proper clearances from combustibles (Figure 2A/2B). *Verify according to your local safety codes.*
- Safe, easy access for servicing (Figure 2A/2B).
- Adequate combustion air per ASME CSD-1, NFPA 31, and local codes (Reference Section 8).
- Proper stack installation and materials (Reference Section 4).



WARNING: For the safe installation and operation of the CTB, the boiler cannot be raised above the floor level, suspended from the ceiling, installed on a raised platform, or placed over top of any equipment, office space, parts room, etc. or installed in any other manner than directly on a concrete floor.

Selecting a Location (continued)

Adhere to the following *minimum* clearances from combustibles. Specifications are also provided for servicing clearance. Be sure to check state and local codes which may differ from these specifications. Refer to pages A4 through A7 for boiler dimensions.

Fig. 2A/2B Description	Clearance from Combustibles	Clearance for Service
A Above	18"	18"
B Front	24"	48"
C Stack	18"	18"
D Rear	6"	40"
E L.H. Side	6"	6"
F R.H. Side	30"	30"
G Bottom	6"	6"

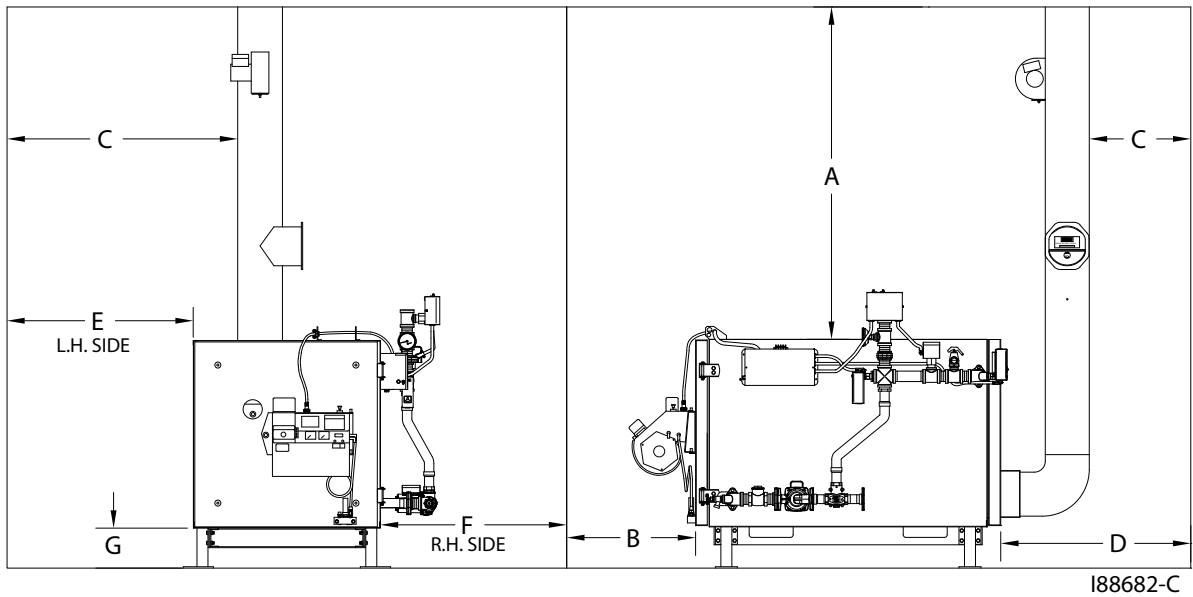

Figure 2A - Single Boiler Minimum Installation Clearances

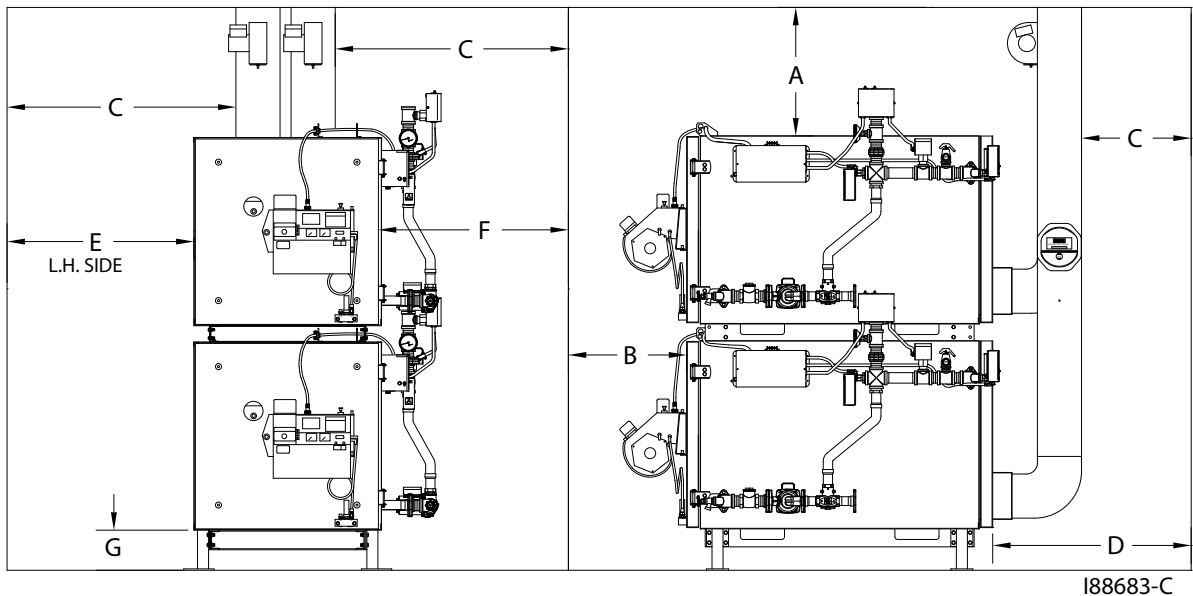

Figure 2B - Dual-Stacked Boilers Minimum Installation Clearances

SECTION 3: COIL TUBE BOILER ASSEMBLY

Understanding Assembly

Assembling your Clean Burn Coil Tube Boiler (CTB) is a multi-step process. Note that some assembly procedures apply only to certain CTB installations or configurations (i.e. single model or dual-stacked boilers); the assembly procedures are outlined below as they appear in this section.

Be sure to refer to the appropriate instructions for your CTB configuration.

Single Boiler Assembly Only

- Installing the CTB on the Support Stand

Dual-Stacked Boiler Assembly Only

- Assembling the Dual-Stacked Boiler

Assembly For All Boilers

- Connecting the CTB
- Installing the Ceramic Sleeve
- Checking the Burner Nozzle and Electrodes
- Installing the Connector Block on the CTB Door
- Installing the Oil Line Tubing
- Installing the Air Line Tubing
- Locking the Burner into Firing Position

NOTE: PLUMBING ASSEMBLY IS SHIPPED DRY FIT ONLY. DO NOT INSTALL UNTIL PLUMBING COMPONENTS ARE RE-ASSEMBLED WITH PROPER THREAD SEALANT.

Single Boiler Assembly

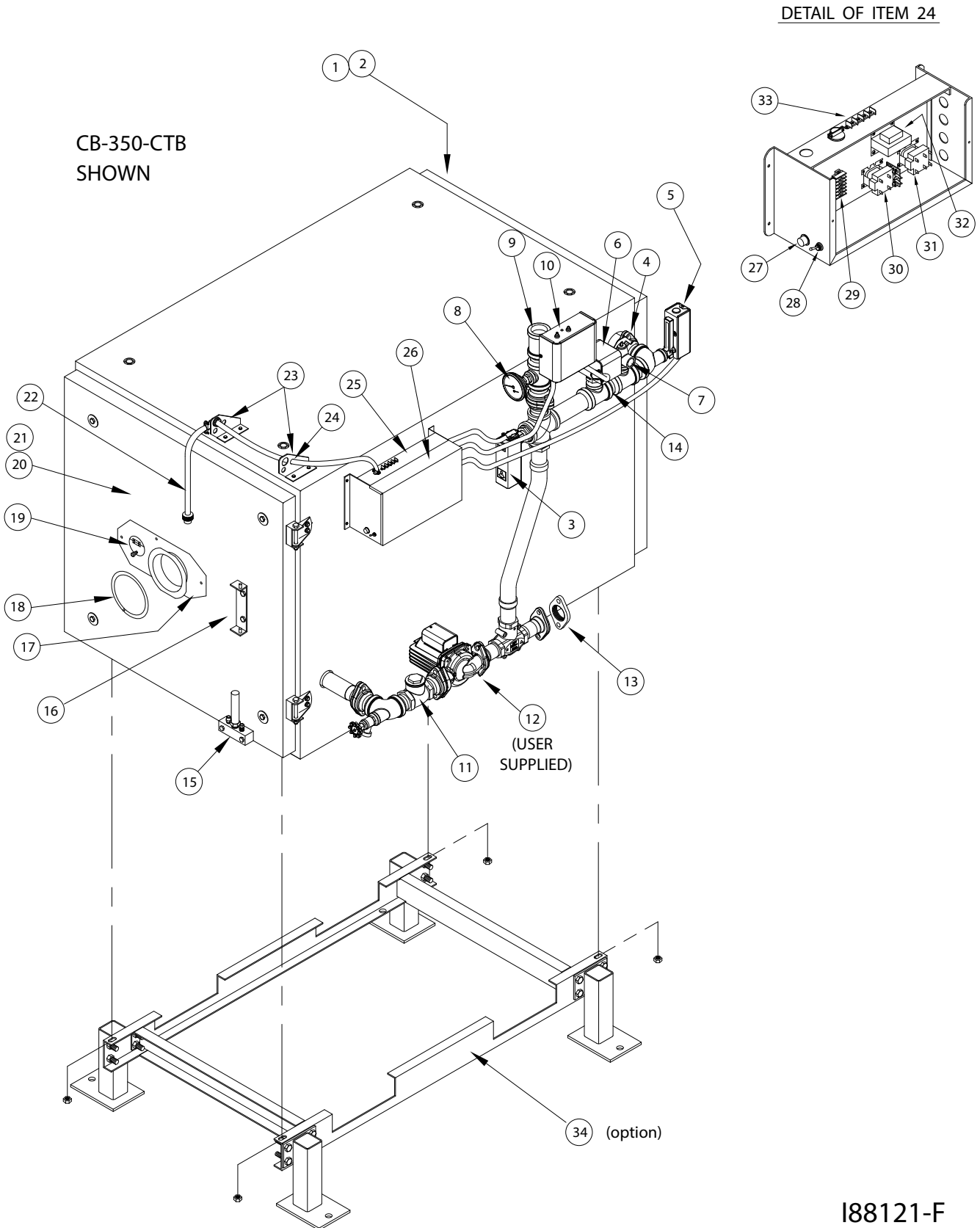

I88121-F

Coil Tube Boiler Operator's Manual: Models CB-200-CTB, CB-350-CTB, and CB-500-CTB

CB-350-CTB PARTS LIST			
NUMBER	QTY	PART #	DESCRIPTION
34	1	90188	BOILER STAND (optional)
33	1	33331	TERMINAL BLOCK
32	1	33327	TRANSFORMER 120V-24V
31	1	33328	RELAY DPDT
30	1	33352	RELAY DELAY
29	1	33486	TERMINAL BLOCK ASSEMBLY
28	1	33286	SWITCH DPDT
27	1	33168	AMBER LIGHT
26	1	27058	CONTROL BOX LID
25	1	12240	CONTROL BOX 120 AC
24	1	33105	SNAP IN BUSHING
23	2	27158	L-BRACKET
22	1	33546	CONNECTOR CORD
21	1	31176	INSULATION - DOOR
20	1	11405	DOOR W.A.
19	1	21077	PORT LID
18	1	14084	ROPE GASKET
17	1	11583	BURNER MOUNT W.A.
16	1	11582	HINGE BRACKET W.A.
15	1	13141	ACCUMULATOR BLOCK ASSEMBLY
14	1	14272	UPPER PIPE ASSEMBLY
13	1	35061	1-1/2" FLANGE
12	1	35078	CIRCULATOR PL36 115V 60Hz
11	1	14293	CHECK VALVE AND PIPE ASSEMBLY
10	1	13110	LOW WATER CUT-OFF
9	1	14274	LOW WATER PIPE ASSEMBLY
8	1	33330	GUAGE BOILER TEMP/PRESS
7	1	35048	RELIEF VALVE 3/4" MALE
6	1	35123	FLOW SWITCH TACO
5	1	28149	HIGH TEMP CUT-OFF
4	1	35079	COIL FLANGE 1-1/4"
3	1	28150	AQUASTAT
2	1	31166	INSULATION PANEL
1	1	11380	PANEL 350 REAR W.A.

PARTS THAT DIFFER ON THE CB-200-CTB			
NO	QTY	PART #	DESCRIPTION
34	1	90200	BOILER STAND (optional)
22	1	33508	CONNECTOR CORD
21	1	31216	INSULATION 200 DOOR
20	1	11540	DOOR W.A.
14	1	14300	UPPER PIPE ASSEMBLY
13	1	35079	1-1/4" FLANGE
12	1	11095	CIRCULATOR TACO 0011 115 V
11	1	14298	CHECK VALVE AND PIPE ASSY
9	1	14299	LOW WATER PIPE ASSEMBLY
4	1	35116	COIL FLANGE 1" NPT
2	1	31215	INSULATION PANEL
1	1	11539	PANEL 200 REAR W.A.

PARTS THAT DIFFER ON THE CB-500-CTB			
NO	QTY	PART #	DESCRIPTION
34	1	90206	BOILER STAND (optional)
22	1	33546	CONNECTOR CORD
21	1	31240	INSULATION 500 DOOR
20	1	11564	DOOR W.A.
14	1	14315	UPPER PIPE ASSEMBLY
13	1	35120	FLANGE 2" SET
12	1	35130	CIRCULATOR TACO 2400-50/2 115V
11	1	14314	CHECK VALVE AND PIPE ASSY
9	1	14313	LOW WATER PIPE ASSEMBLY
4	1	35121	FLANGE 1-1/2" SET
2	1	31239	INSULATION PANEL
1	1	11563	PANEL 500 REAR W.A.

	200-CTB	350-CTB	500-CTB
Refractory Cylinder	21120	21140	21174
Refractory Cylinder Stand	27155	27190	27200

Single Boiler Assembly

Installing the CTB on the Support Stand

WARNING: Use extreme caution when moving and lifting the CTB (with a forklift) into place on the support stand. One CTB can weigh up to 2000 pounds (approximate). Clean Burn recommends placing safety blocking underneath the unit until it is properly installed and secured on the support stand. *Failure to follow these basic safety guidelines may result in serious personal injury and/or damage to the unit.*

1. Refer to Figure 3A to become familiar with the components required for CTB assembly.
2. Assemble the CTB support stand as shown in Figure 3B, using the hardware provided.
3. Move the support stand into the approximate position where the CTB is to be installed, and place blocks (approximately 10 inches high) inside the stand to provide safety support for the boiler.
4. Use a forklift to carefully lift the CTB into position over top of the support stand.

WARNING: Secure the boiler to the forklift prior to lifting to prevent possible equipment damage or personal injury.

5. Lower the boiler down onto the safety blocks positioned inside the support stand.
6. Insert bolts (provided) into the keyhole slots in the boiler, and then lift the stand in position against the bottom of the boiler.
7. Tighten the bolts to firmly attach the stand to the bottom of the boiler.
8. Carefully lift the assembled boiler (with stand) off the safety blocks and move the unit into place.
9. Proceed with the remainder of boiler assembly procedures marked for **ALL CTB Models**.

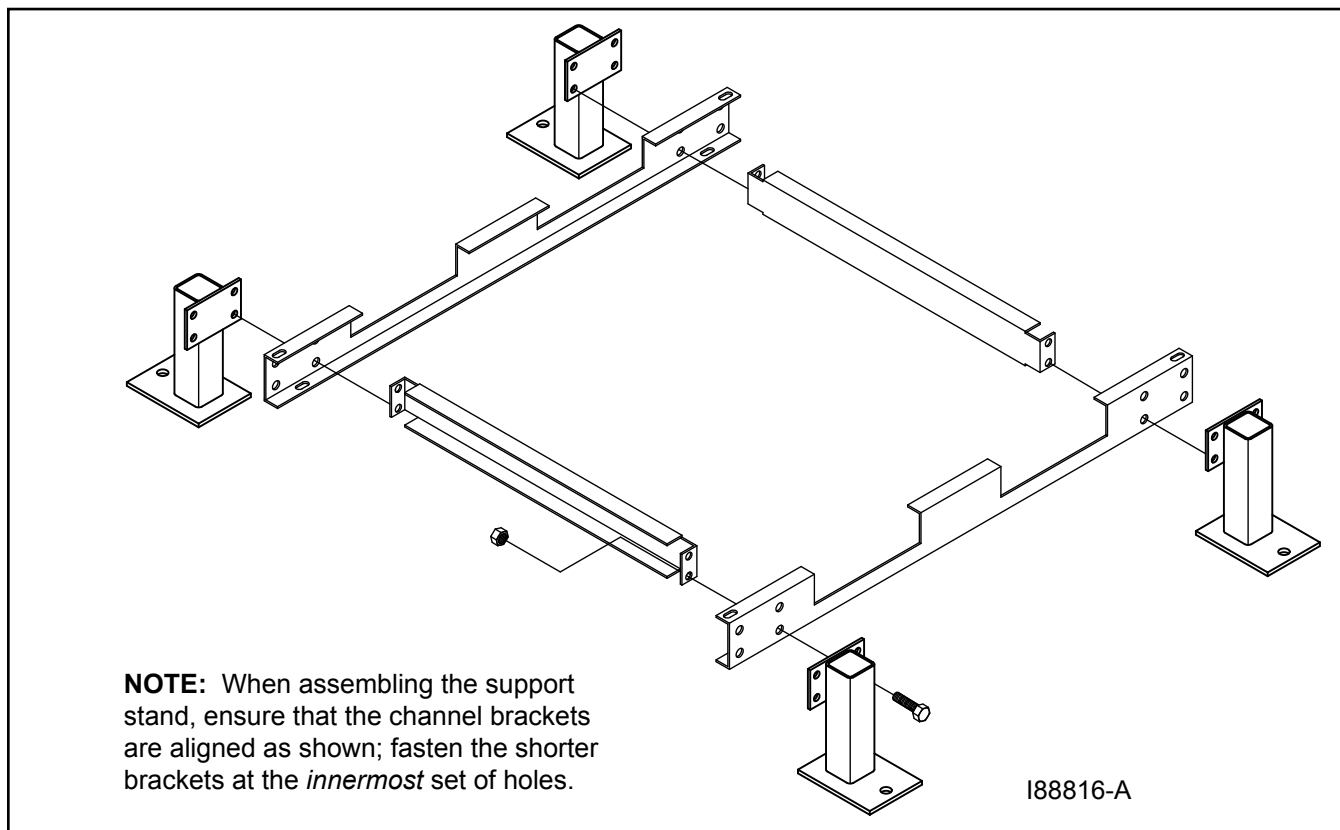

Figure 3B - Assembling the Support Stand

Dual-Stacked Boiler Assembly

Assembling the Dual-Stacked Boiler



WARNING: Use extreme caution when moving and lifting one of the CTB's (with a forklift) into place on the support stand. One CTB can weigh up to 2000 pounds (approximate). Clean Burn recommends placing safety blocking underneath the unit until it is properly installed and secured on the support stand. *Failure to follow these basic safety guidelines may result in serious personal injury and/or damage to the unit.*

ATTENTION: Dual-stacked units may be installed in several combinations: two CB-200-CTB boilers, two CB-350-CTB boilers, two CB-500-CTB boilers, or any combination of two models with the larger unit on the bottom. For optimal system functioning and to prevent system damage, *each* boiler must be installed/piped individually as shown in Figure 3C.

1. Refer to Figures 3C and 3D. Move the support stand into the approximate position where the dual-stacked boiler is to be installed, and place blocks (approximately 10 inches high) inside the stand to provide safety support for the boiler.

NOTE: If the support stand has not been assembled, refer to Figure 3B.

NOTE: Only use 7 1/2" legs when stacking the boilers. Taller legs may be unstable.

2. Use a forklift to carefully lift one CTB into position over top of the support stand.



WARNING: Secure the boiler to the forklift prior to lifting to prevent possible equipment damage or personal injury.

3. Lower the boiler down onto the safety blocks positioned inside the support stand.
 4. Insert bolts (provided) into the keyhole slots in the boiler, and then lift the stand in position against the bottom of the boiler.
 5. Tighten the bolts to firmly attach the stand to the bottom of the boiler.
 6. Carefully lift the assembled boiler (with stand) off the safety blocks and move the unit into place for the rest of assembly.
- NOTE:** This boiler will be referred to as the "bottom" boiler for the remainder of this procedure.

(Procedure continued on page 3-6)

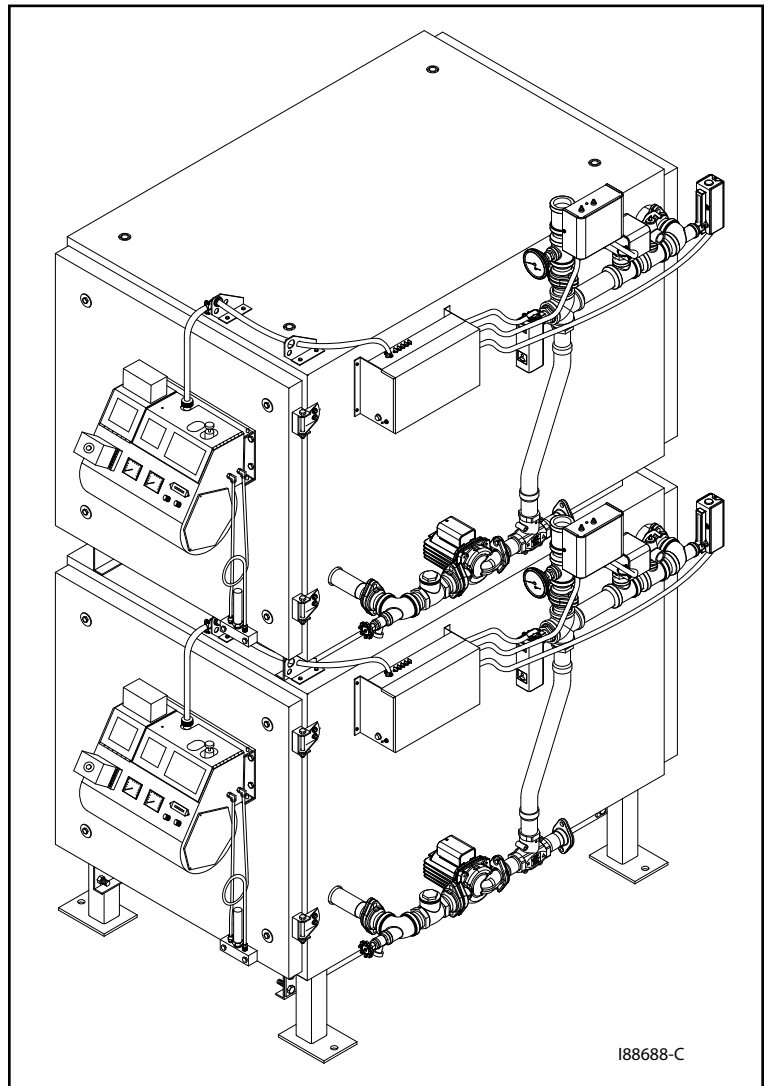

Figure 3C - Dual-Stacked Boilers (Completely Assembled)

Dual-Stacked Boiler Assembly

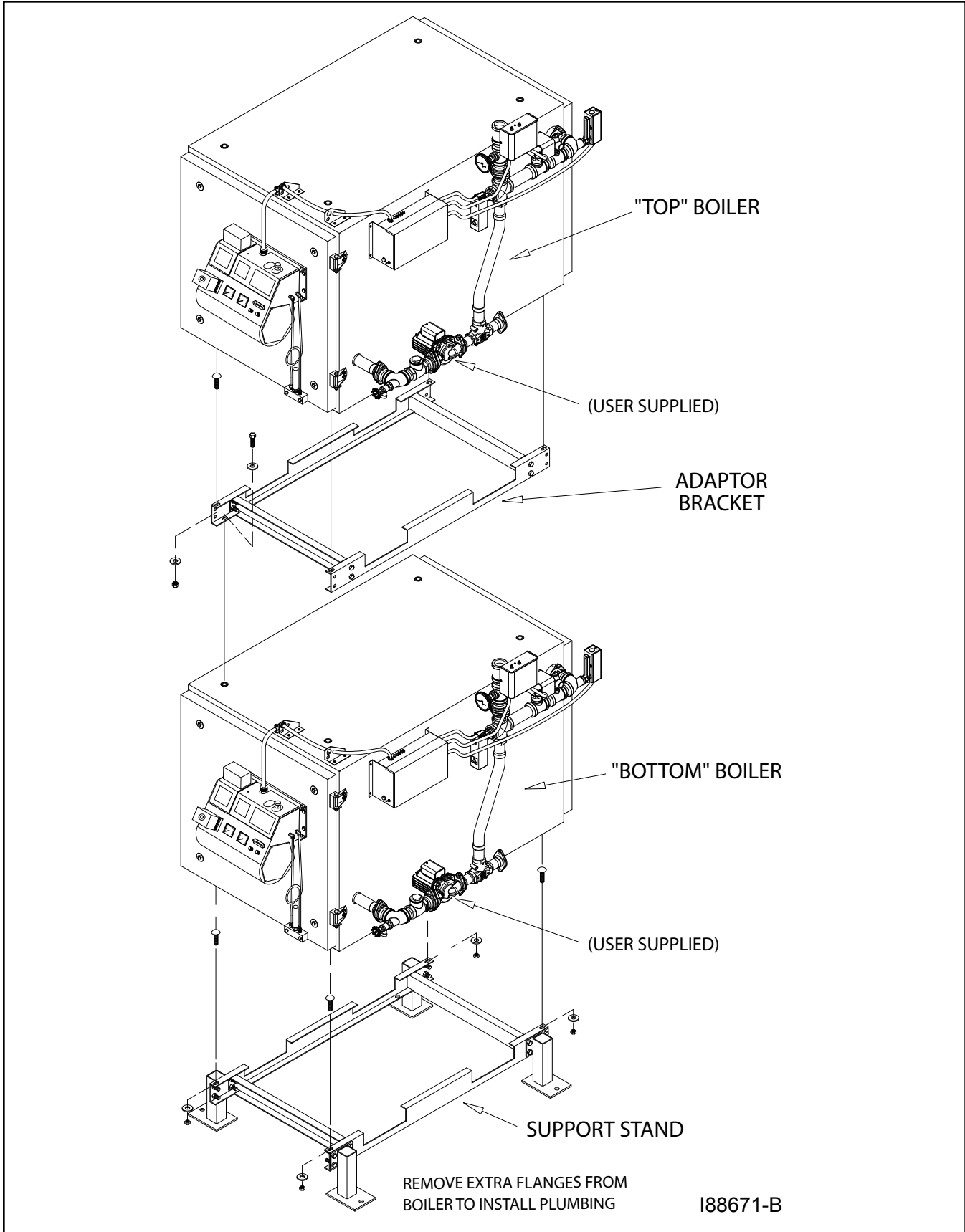

Figure 3D - Dual-Stacked Boiler Assembly Detail

Dual-Stacked Boiler Assembly

Assembling the Dual-Stacked Boiler (continued)

7. Refer to Figures 3D and 3E. Assemble the adaptor bracket using the 1" x 3/8" bolts provided.
NOTE: The adaptor bracket is installed between the two boilers; it is fastened to the underside of the "top" boiler unit.
8. If you have not already done so, remove the pre-assembled hardware from the top of the "bottom" boiler. You will use this hardware to fasten the adaptor bracket.
9. Use a forklift to carefully lift the "top" boiler unit from underneath (*see safety warning at the beginning of this procedure*).
10. Attach the adaptor bracket to the bottom of the boiler using the 1" x 3/8" carriage bolts provided. DO NOT completely tighten the bolts until the two units are assembled together.
NOTE: The notches on the adaptor bracket are designed to fit around standard forklift forks.
11. After the bracket has been attached to the underside of the "top" boiler unit, move the "top" unit into position over the "bottom" unit.
12. Carefully lower the "top" boiler down onto the "bottom" boiler, watching for alignment of the bracket holes and the holes in the top of the boiler below.
13. Install the hardware through the lower set of holes in the adaptor bracket into the top of the "bottom" boiler while checking for proper alignment of the two units. Ensure that ALL hardware is securely tightened.

NOTE: When stacking a CB-200-CTB on top of a CB-350-CTB use an additional set of side channels turned 180 degrees to help distribute the load around the fork lift notches. This will require lifting the "top" boiler unit from the front rather than the side. Install the front channel into the adaptor bracket after the "top" unit is set on the "bottom" unit.

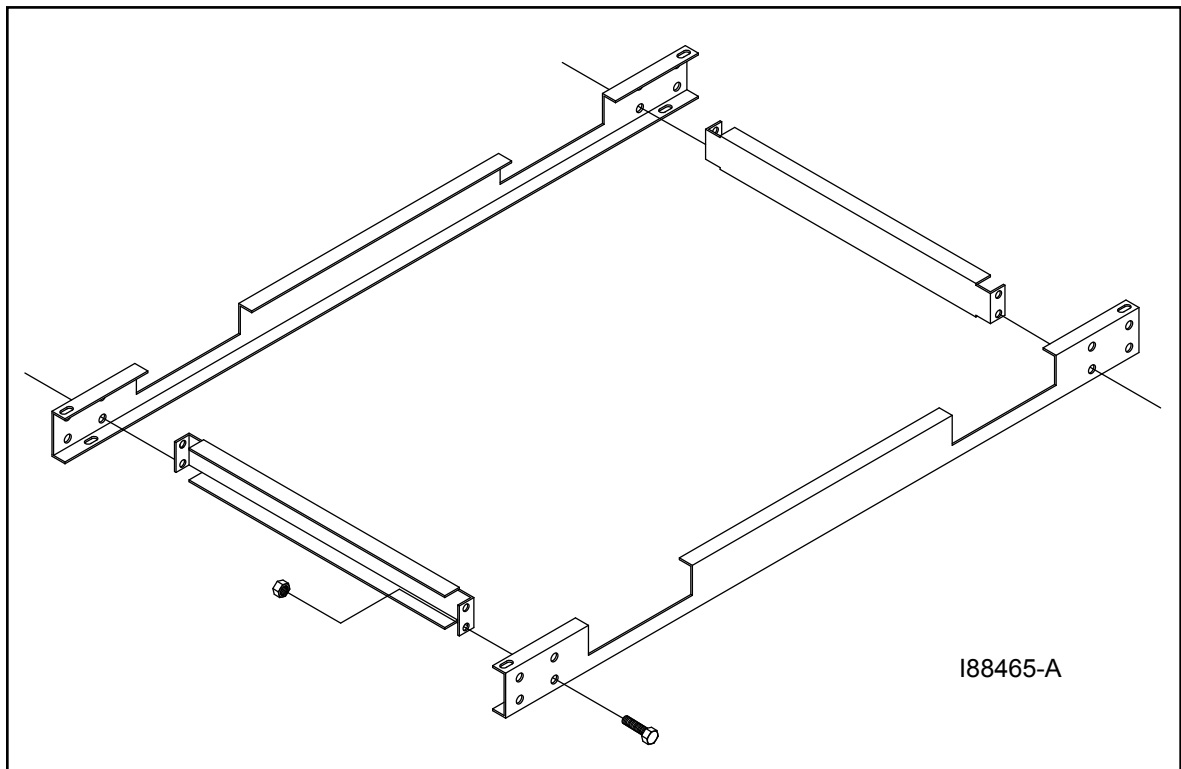

Figure 3E - Dual-Stacked Boiler Adaptor Bracket

Assembly for ALL Boilers

Connecting the CTB

Refer to Figures 3A, 3C, and 3D. Connecting the boiler involves three activities:

- Supply Side Connections
- Return Side Connections
- Wiring

NOTE: If you are installing dual-stacked boilers, each boiler must be installed in the same manner according to the following guidelines for connections/wiring. *Each boiler must be protected with its own low water cut-off and MUST be piped individually (i.e. piping dual-stacked units together with a single supply or return line is strictly PROHIBITED).*

NOTE: PLUMBING ASSEMBLY IS SHIPPED DRY FIT ONLY. DO NOT INSTALL UNTIL PLUMBING COMPONENTS ARE RE-ASSEMBLED WITH PROPER THREAD SEALANT.

Supply Side Connections

- Install the pre-assembled low water cut-off onto the supply piping flange.
- Place a flange gasket between the two flanges, and tighten the bolts to secure this part.
- Install the temperature/pressure gauge into the first tee (the 1/2" tapping). Be sure to use pipe dope on the threads of the gauge. Tighten the gauge into the tee.
- Install the probe of the low water cut-off into the upper tee, using pipe dope on the threads of the probe. Tighten into the tee.
- Install the low water cut-off control onto the probe and secure.
- Connect the wiring harness from the CTB control box to the low water cut-off. Refer to the CTB wiring diagram in Appendix B at the back of this manual.

Return Side Connections

- Mount the boiler circulator onto the flanged check valve assembly mounted on the boiler. Place a gasket between the two flanges and tighten.
- Install the return piping assembly onto the other side of the circulator flange. Place a gasket between the two flanges and tighten.
- Isolation valves must be installed on supply and return plumbing connections.

Wiring

- For *each* boiler, connect the wire from the CTB control box to the circulator. Refer to the CTB wiring diagram in Appendix B as needed. If necessary, excess length may be trimmed from the circulator wires.

Assembly for ALL Boilers

Installing the Ceramic Sleeve in the Boiler

NOTE: The ceramic target is factory-installed.

1. Refer to Figures 3F and 3G.
2. Swing open the clean-out door on the CTB front to gain access to the combustion chamber.
3. Install the stand for the ceramic sleeve as detailed in Figure 3F. Position the stand on the coils approximately 3" in from the door opening.
4. After the ceramic sleeve has been installed and positioned properly, close the clean-out door.
5. Tighten the four (4) nuts and washers in a criss-cross pattern until all are snug.

NOTE: The ceramic sleeve needs to seat firmly against the door insulation for proper combustion. Carefully position the ceramic sleeve on the stand so that it extends out slightly beyond the door opening, so that the door will push the ceramic sleeve in place as it is closed.

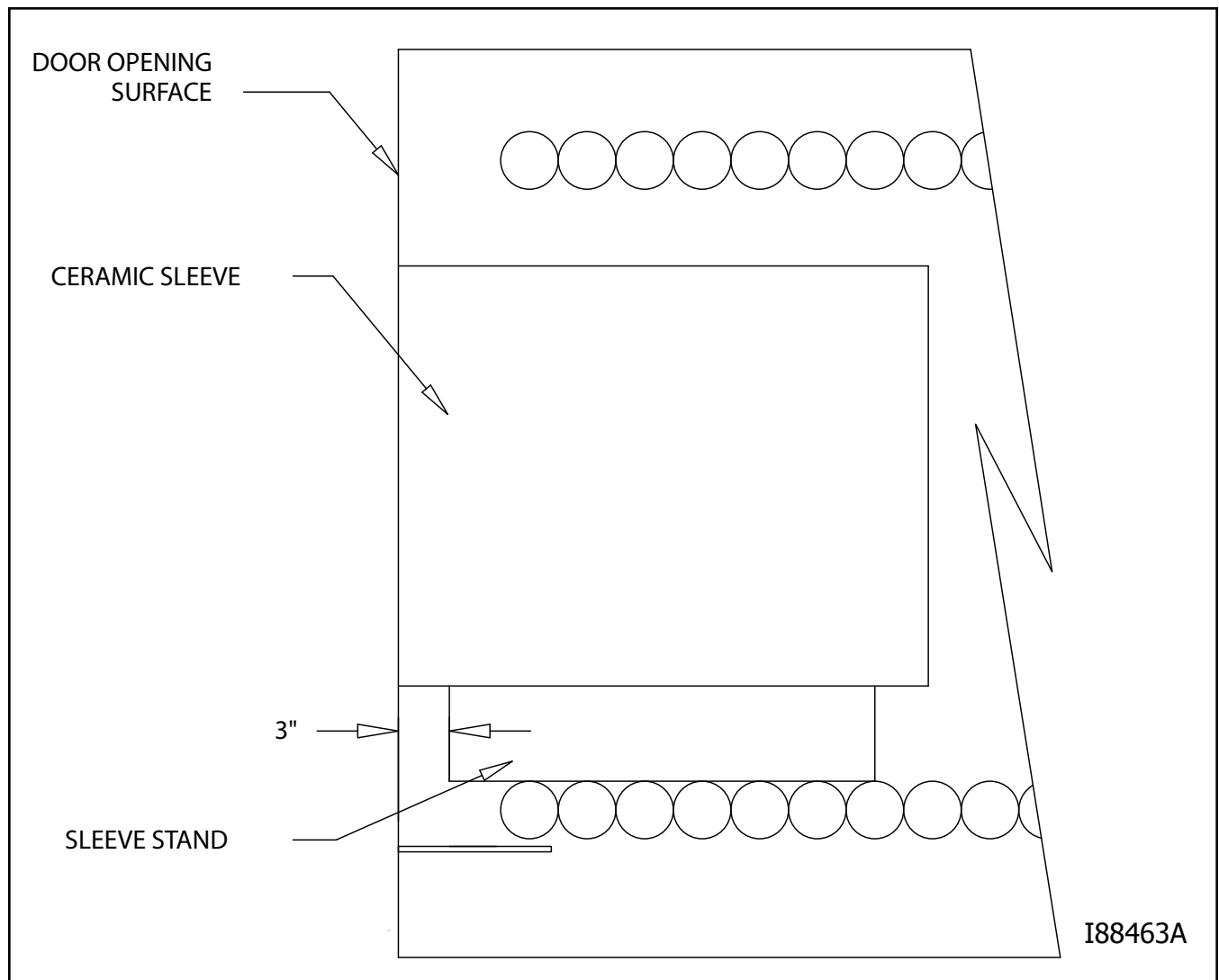

Figure 3F -Positioning of the Sleeve Stand and Ceramic Sleeve

Assembly for ALL Boilers

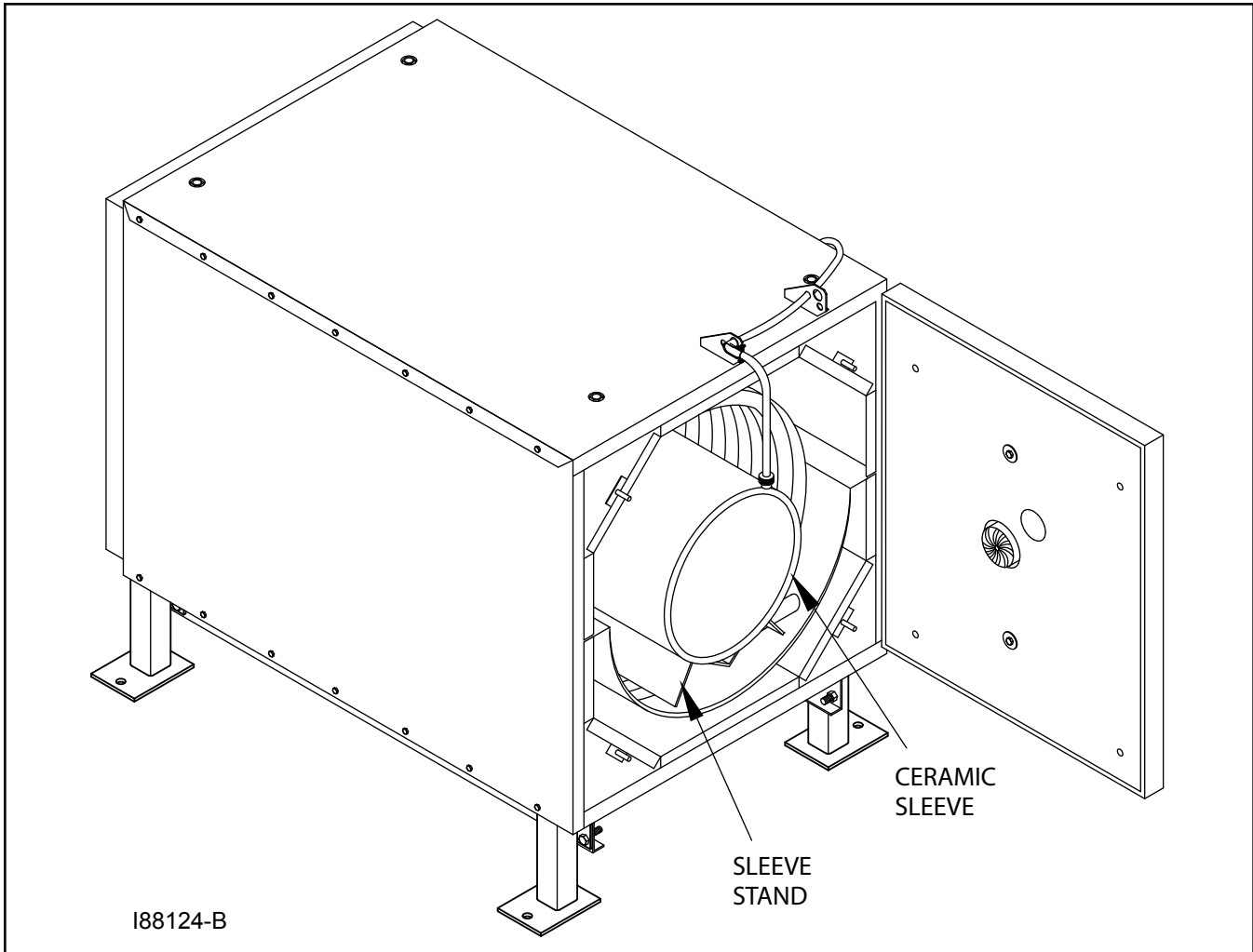

Figure 3G - Sleeve Stand and Sleeve Installed in the Combustion Chamber

Assembly for ALL Boilers

Checking the Burner Nozzle and Electrodes

NOTE: The burner nozzle is factory installed. Models CB-200-CTB and CB-350-CTB use a Delavan 9-5 nozzle. Model CB-500-CTB uses a 9-28 Delavan nozzle. The nozzle size is indicated on the nozzles as shown in Figure 3H. Refer also to **Appendix A** at the back of the manual for additional specifications on the burner nozzle.

ATTENTION: Check the electrode settings as specified in Figure 3H. The electrode settings must be correct for your burner to operate properly.

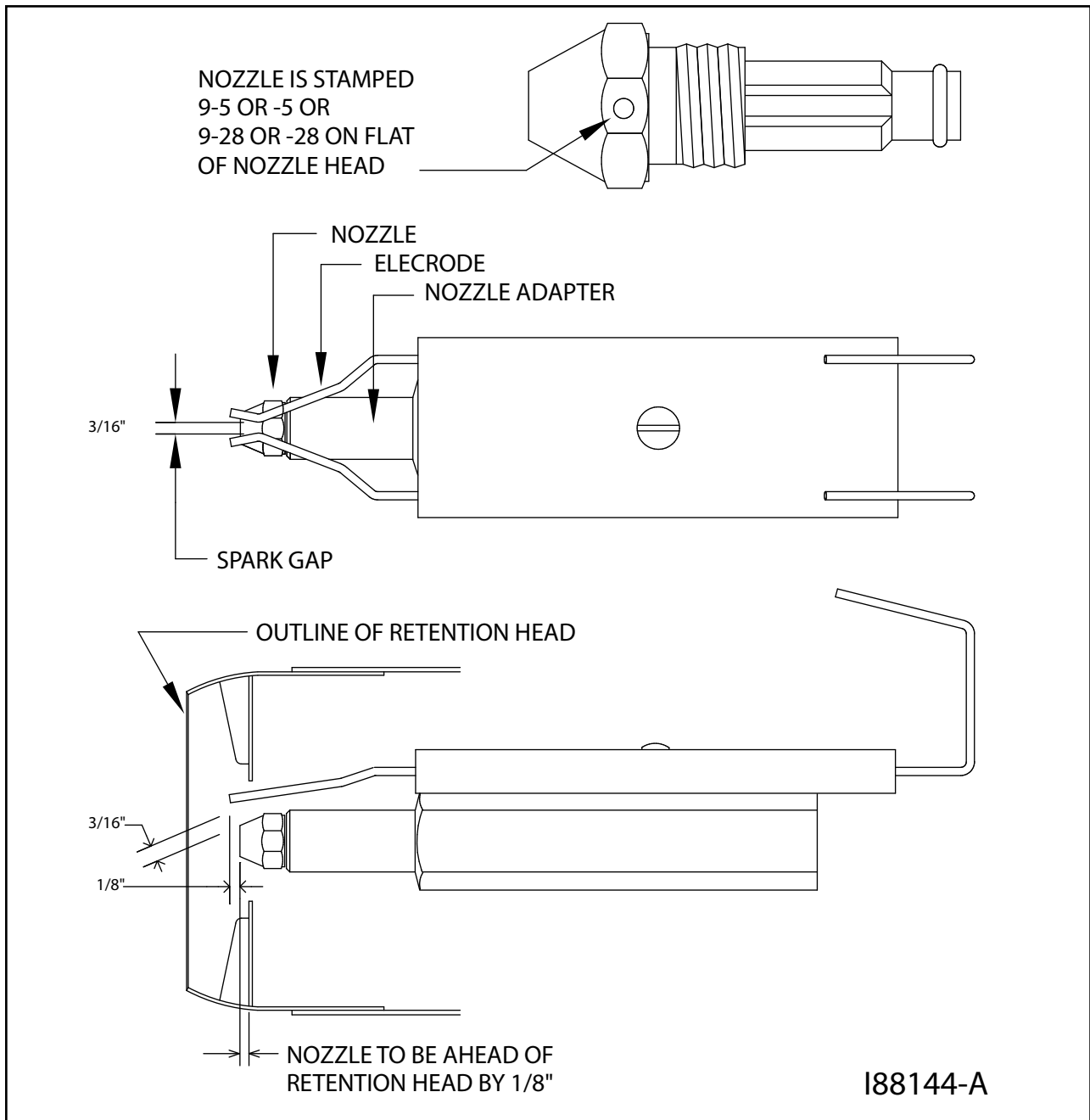

Figure 3H - Burner Nozzle and Electrode Specifications

Assembly for ALL Boilers

Mounting the Burner on the Hinge Bracket

NOTE: The burner may have been mounted on the CTB at the factory. If this is the case, simply check the clearance between the retention head and the boiler to make sure the burner swings freely into firing position. If adjustments are necessary, follow the procedure below to adjust the hinge bracket bolts.

1. Remove the nut from the burner mounting flange on the boiler cabinet, and set it aside for later use.
2. Lift the burner into position and mount it on the hinge bracket of the boiler cabinet.
3. Carefully swing the burner and check the clearance between the retention head and the boiler throat. There must be at least 1/8" clearance, so the retention head is not "bumped" as you swing the burner into firing position.

If the retention head "bumps" the boiler throat, adjust the hinge bracket bolts as follows:

- While supporting the burner, slightly loosen the two (2) hinge bracket bolts.
- Carefully re-position the burner so it swings freely into its firing position.
- With the burner in its firing position, re-tighten the hinge bracket bolts.

Installing the Connector Block on the CTB Door

1. Refer to Figure 3I on the next page.
2. Use the two (2) bolts to install the aluminum connector block onto the CTB cabinet.
3. Remove and discard the red caps and plugs from the fittings and ports on the connector block. DO NOT allow any dirt/debris to enter these components during CTB assembly.

ATTENTION: The connector block includes an accumulator. The accumulator functions like a shock absorber on the oil line to prevent pressure buildup and protect vital burner components. It is important that the connector block is installed as shown so that the accumulator is in a vertical position to prevent sediment from settling in the accumulator. *Never operate your CTB without the connector block and accumulator properly installed on the boiler, or damage may occur to vital burner components.*

ATTENTION: DO NOT use teflon tape or teflon pipe dope products on any fittings; teflon residue will plug vital burner components. Non-hardening pipe dope compounds are recommended.

Assembly for ALL Boilers

Installing the Oil Line Tubing

NOTE: DO NOT disassemble the compression fitting from the swivel fitting. To prevent leaks, the NPT threads of the compression fitting have been sealed with hydraulic sealant during assembly of the fittings at the factory.

1. Remove and discard the outer red protective caps from the oil line tubing.
2. Loosely install the oil line tubing into the oil line fitting on the burner.
3. Use a wrench to slightly rotate the oil line fitting on the burner counterclockwise so the tubing lines up with the swivel assembly. Slightly bend the tubing as shown in Figure 3I, if required, to "line up" the oil line.
4. Make sure that the curl in the oil line is positioned as shown in Figure 3I so that the burner can swing open correctly.
5. Install the oil line tubing and tighten the nuts on the compression fittings. **DO NOT** overtighten these fittings to avoid damaging the ferrules.

NOTE: You may also check the positioning of the oil line according to Figure 3J on the next page which provides a larger front view of the connector block assembly.

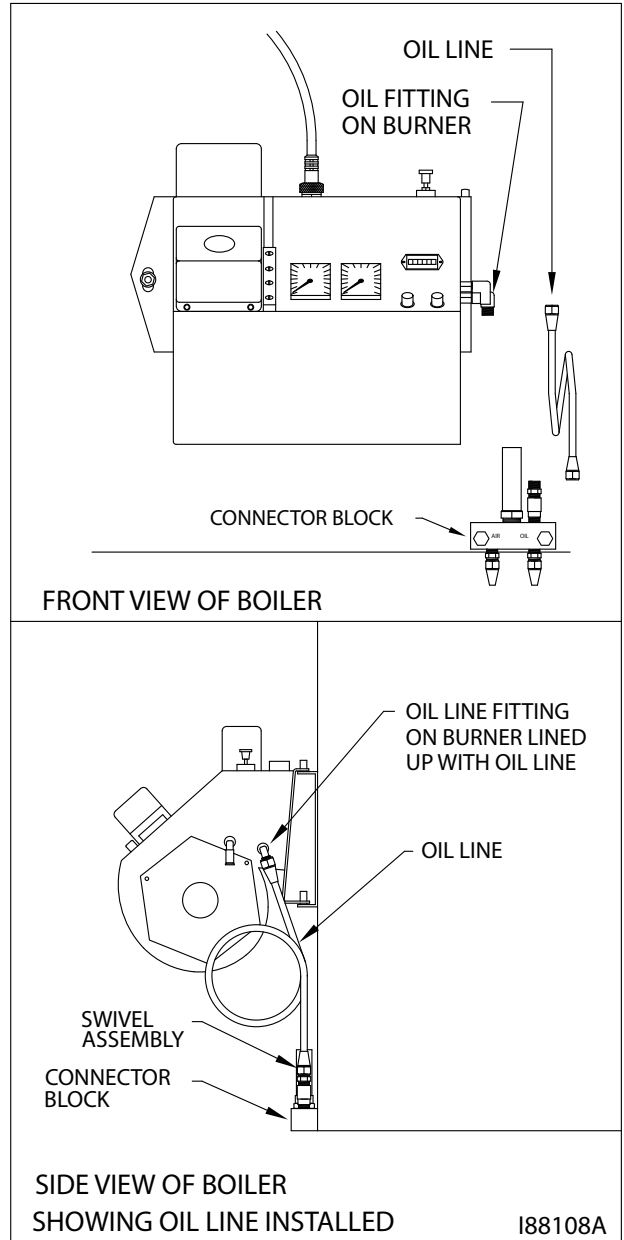

**Figure 3I - Installation of
Connector Block and Oil Line**

Assembly for ALL Boilers

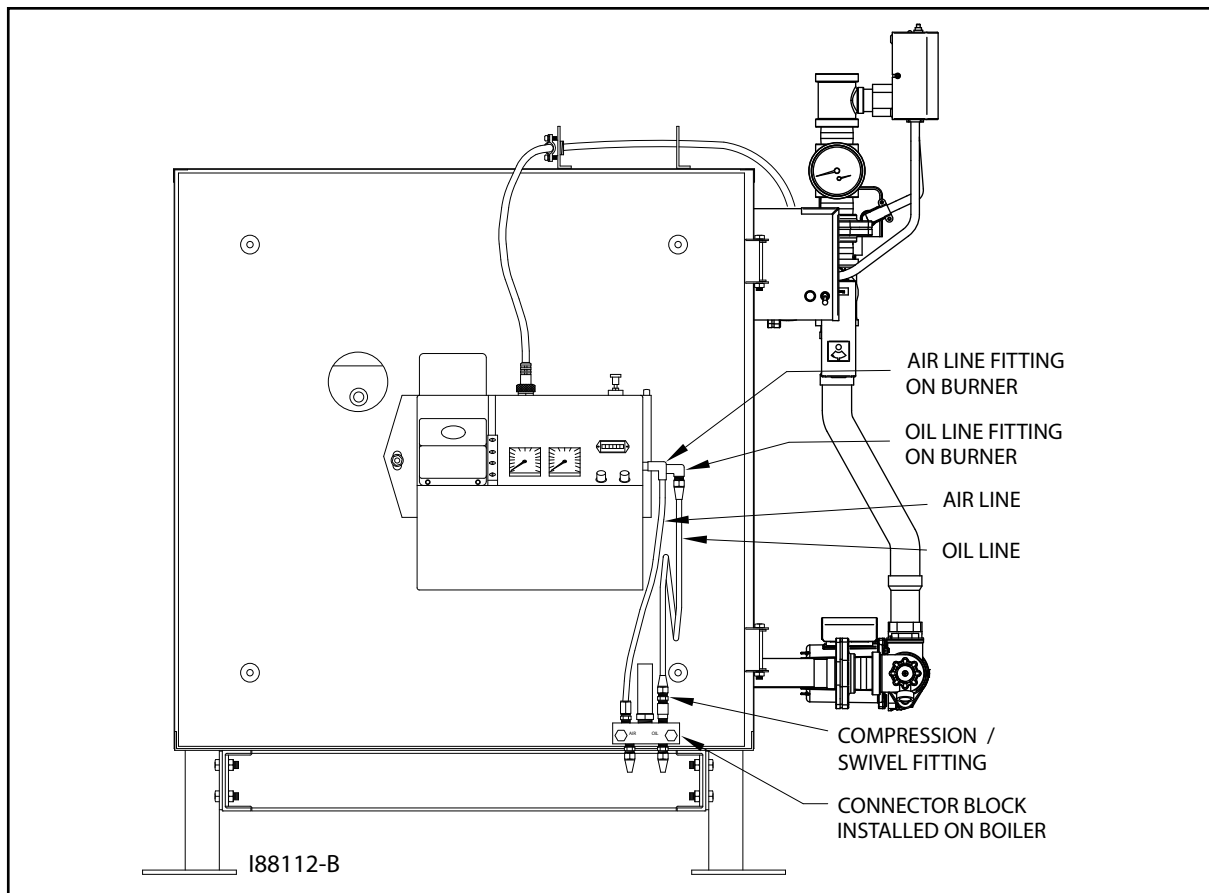

Figure 3J - Installation of Connector Block, Oil Line and Air Line (Front View)

Installing the Air Line Tubing

1. Remove and discard the outer red protective caps from the air line tubing.
2. Refer to Figure 3J. Push the air line tubing into the swivel fitting on the connector block until the tubing bottoms out in the fitting.
3. Repeat this procedure to connect the air line tubing to the air line fitting on the side of the burner.

Locking the Burner into Firing Position

1. Swing the burner into firing position.
2. Install and tighten the lock nut on the mounting plate bolt to secure the burner in its firing position.
3. Plug the burner electrical cable into the receptacle on the top of the burner housing.
4. Tighten the locking ring to secure the electrical cable.

NOTE: Be sure to properly align the plug when plugging it into the receptacle. See Fig 3K.

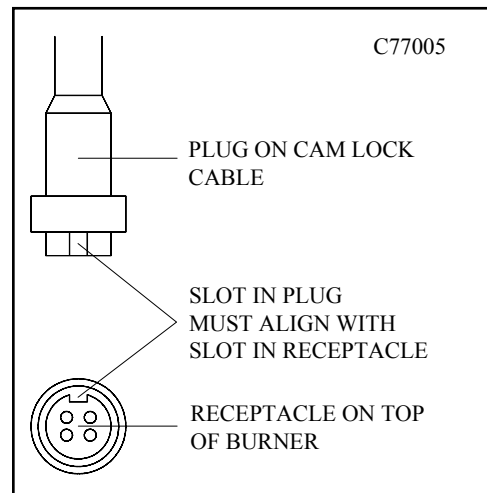

Figure 3K - Detail of Burner Electric Receptacle

SECTION 4: COIL TUBE BOILER INSTALLATION

Understanding Installation

Installing your Clean Burn Coil Tube Boiler (CTB) is a multi-step process which includes:

- | | |
|------------------------------------------|----------------------------------------|
| (1) Oil Tank Installation Specifications | (5) Installing the Compressed Air Line |
| (2) Installing the Metering Pump* | (6) Wiring the CTB and Pump |
| (3) Connecting Water to the CTB | (7) Installing the Stack |
| (4) Installing the Oil Lines | (8) Inspecting the Installation |

***NOTE:** This manual provides information for the installation of a metering pump with the CTB. If you ordered a J-pump, please also refer to the separate *J-Pump Installation Manual* included with your shipment.

Clean Burn recommends that you review all procedures before beginning installation, paying careful attention to safety information statements. **Figures 4A / 4B provide a general overview of a typical coil tube boiler installation and should be reviewed closely before proceeding.**



WARNING: The installation, operation, and maintenance of this equipment must be accomplished by qualified personnel and in compliance with the specifications in the Clean Burn Operator's Manual and with all national, state, and local codes or authorities having jurisdiction over environmental control, building inspection and fuel, fire and electrical safety and the following standards:

ASME Section IV	Boiler Code for Pressure Vessels
ASME CSD-1	Controls and Safety Devices for Automatically Fired Boilers
NFPA 30	Flammable and Combustible Liquids Code
NFPA 30A	Automotive and Marine Service Station Code
NFPA 31	Standard for the Installation of Oil Burning Equipment
NFPA 70	National Electrical Code
NFPA 88A	Parking Structures
NFPA 88B	Repair Garages
NFPA 211	Chimneys, Fireplaces, Vents and Solid Fuel Burning Appliances
The International Mechanical Code	
The International Building Code	
The International Fire Code	
The International Fuel Gas Code	

Likewise, the installation, operation, and maintenance of this equipment in **Canada** is to be accomplished by qualified personnel and in compliance with the specifications in the Clean Burn Operator's Manual and in accordance with the regulation of authorities having jurisdiction and the following CSA Standards:

B139	Installation Code for Oil Burning Equipment
B140.0	General Requirements for Oil Burning Equipment
B140.7.2	Oil-Fired Steam and Hot Water Boilers for Commercial and Industrial Use
B214	Installation Code for Hydronic Heating Systems
C22.1	Canadian Electrical Code, Part 1.

Failure to comply with these standards and requirements may result in equipment damage, fire, explosion, personal injury and/or death.



WARNING: Improper installation can adversely affect the proper, safe operation of your CTB. It is critical that your boiler installer reads and follows the instructions provided in this manual.

Typical Installation Diagrams

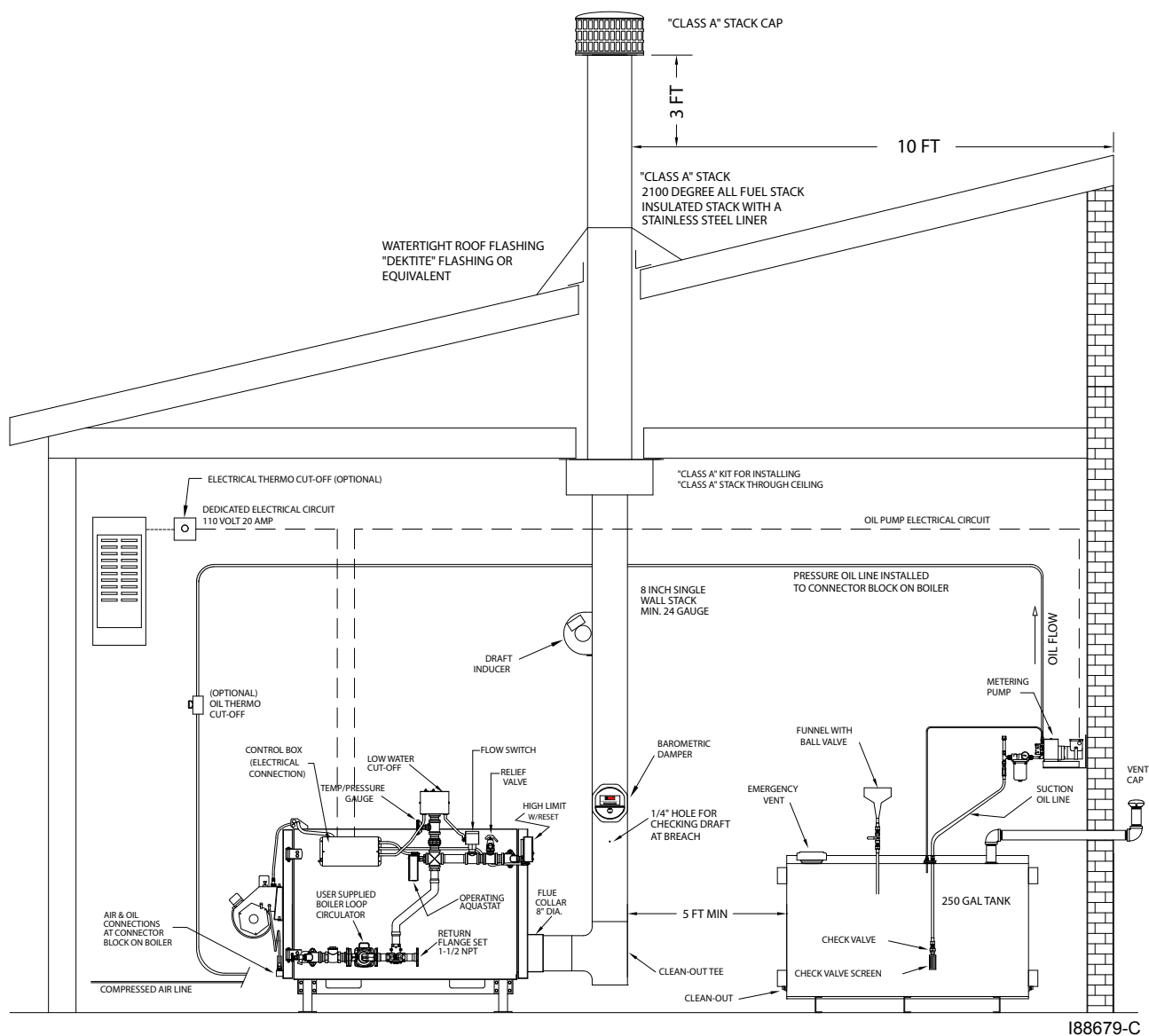
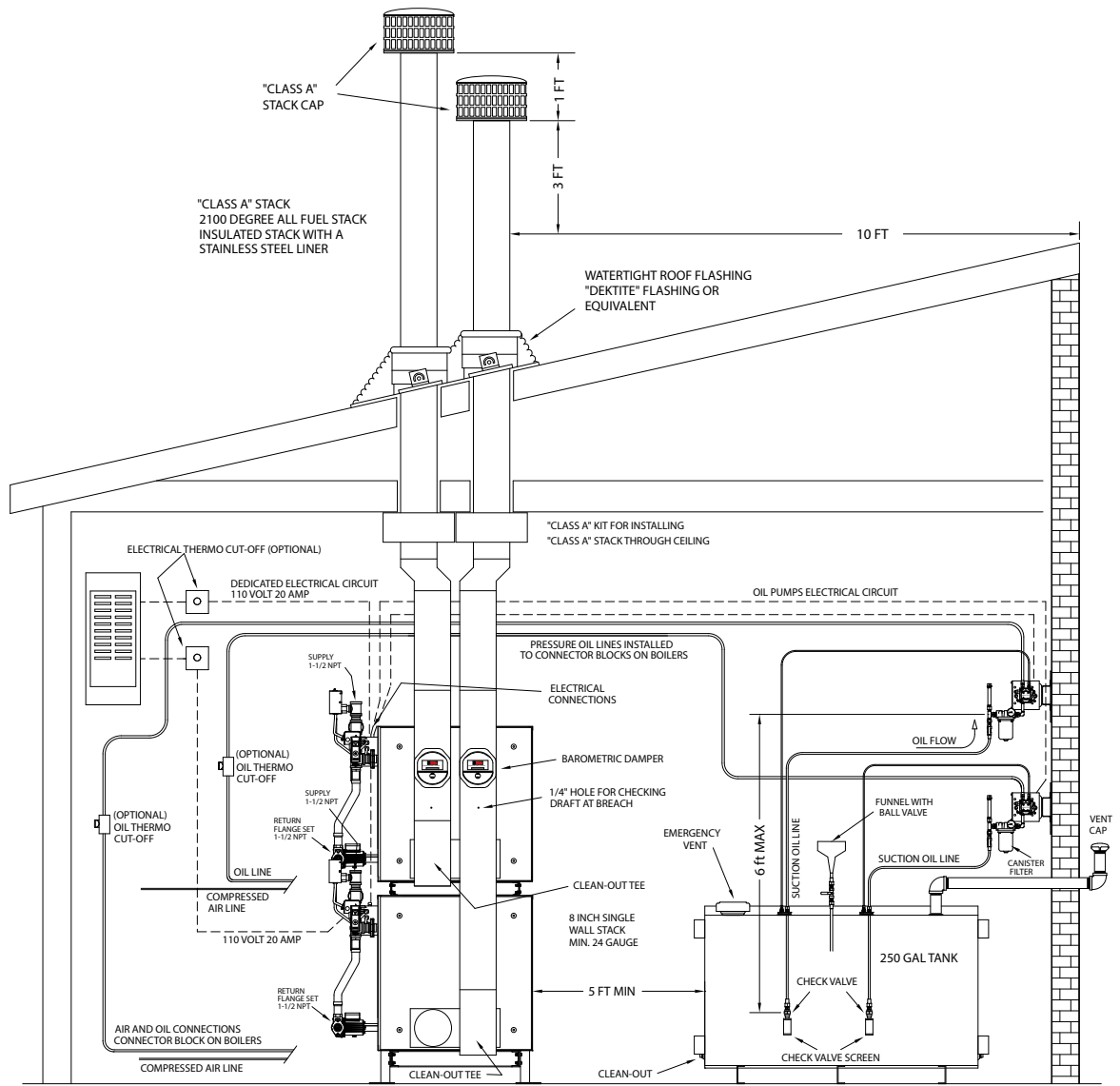

Figure 4A - Typical Single Boiler Installation Diagram (CB-350-CTB Shown)

Typical Installation Diagrams (continued)



188726-C

**Figure 4B - Typical Dual-Stacked Boiler Installation Diagram
(Two CB-350-CTB Boilers Shown)**

Combustion Air Requirements

The CTB system designer/installer must ensure that there is the proper amount of combustion air in the boiler/mechanical room.

Refer to Figure 4C.

Combustion Air is the required amount of air that the equipment needs to permit the satisfactory combustion of oil, the proper venting of combustion gases, and to maintain a safe ambient temperature within the space at safe limits under normal conditions of use.

NFPA 31 requires the following for combustion air:

Units located in confined spaces (units in a boiler room/mechanical room) must have two (2) permanent openings, one near the top of the enclosure and one near the bottom of the enclosure as follows:

1. If all of the air is taken directly from the outside of the building by use of vertical ducts - each of the two openings must have a total free area of not less than 1 square inch per 4,000 BTU/hr (35 square inches per gallon of oil) of the total appliance(s) input rating (NFPA 31, Section 5.4.2.2).
2. If all of the air is taken directly from the outside of the building by use of horizontal ducts - each of the two openings must have a total free area of not less than 1 square inch per 2,000 BTU/hr (70 square inches per gallon of oil) of the total appliance(s) input rating (NFPA 31, Section 5.4.2.2).
3. If all of the air is taken directly from inside of the building - each of the two openings must have a total free area of not less than 1 square inch per 1,000 BTU/hr (140 square inches per gallon of oil) of the total appliances(s) input rating (NFPA 31 Section 5.4.1).

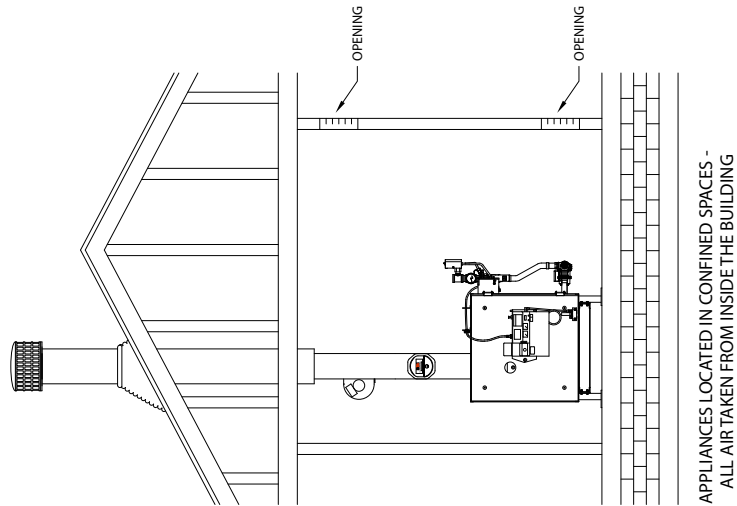
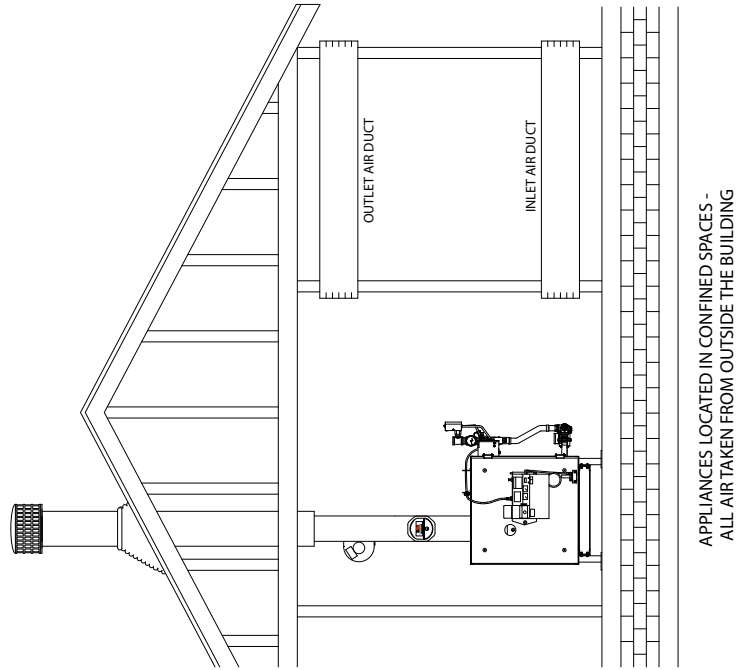
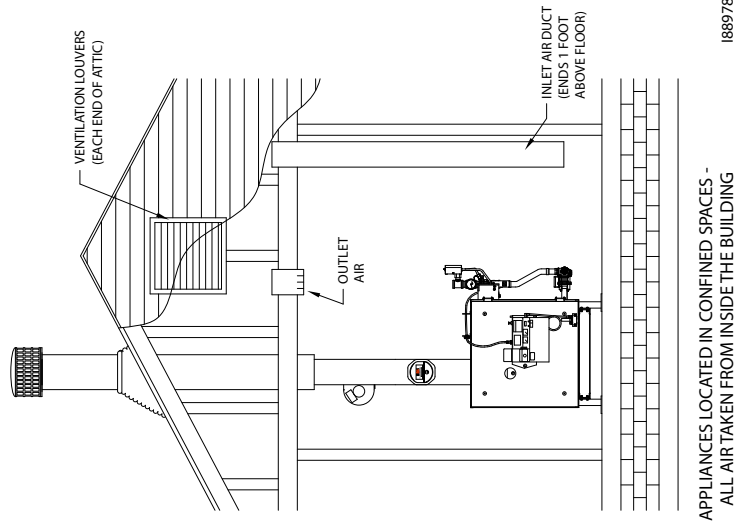

Figure 4C - Air for combustion and ventilation



Oil Tank Installation Specifications

Ensure that your tank installation adheres to the following safety guidelines as stated here and in **Section 1** of this manual.

The tank safety label (shown at right) also summarizes these important specifications for tank installation and usage. If you do not have a copy of this label, please contact your Clean Burn dealer for a copy, which is to be affixed directly to your used oil supply tank.

- **The tank installation must meet all national and local codes.** Consult your local municipal authorities for more information as necessary.
- The tank must be listed to UL 80, UL 142, or equivalent standard.
- Use a **minimum 250-gallon tank.** DO NOT use a 55-gallon drum as a substitute for an appropriate tank. The tank must be large enough to allow water, sludge, etc. to settle out of the used oil.
- Single wall tanks should have a **manual shut-off type valve** on the side of the tank to allow the water, sludge, etc. to be drained from the bottom of the tank.
- All **unused openings in the tank must be plugged** or capped off.
- For optimal system functioning, Clean Burn recommends inside tank installations as shown in Figures 4A and 4B.
- Some codes require the tank to be **vented to the outside** of the building using iron or steel pipe and fittings with an approved vent cap.
- Carefully review the oil tank and pump installation details as shown in Figures 4A, 4B, and 4D, including the metering pump installation and specifications for the oil line installation. (Procedures for installing these components can be found in the following pages.)

⚠ WARNING

**Fire and explosion hazards
To prevent serious injury or death:**

ONLY place these listed substances in this used-oil supply tank:

- Used crankcase oil
- Used automatic transmission fluid
- Used hydraulic oil
- #2 fuel oil

Do NOT place flammable or corrosive substances such as gasoline, chlorinated oils, solvents, paint thinners, or any other unsafe substances in this used-oil supply tank.

Do NOT weld or allow open flame within 35 feet of this used-oil supply tank.

Tank installation MUST comply with NFPA 30 and 31 Fire Codes, including the following requirements:

- Tank must be listed to UL 80 or UL 142.
- Tank must be vented to outside.
- Emergency vent or explosion relief must be installed on tank.
- Inside fill allowed only with funnel including 1/4 turn-to-close fall valve, which must be closed after filling.
- All other openings must be plugged
- All oil lines must be constructed of copper, steel, or brass components. Do NOT use rubber or plastic tubing or piping, or any other inappropriate material.



**Follow all instructions
for tank installation in
Operator's Manual.**

42366 Rev. 2

IMPORTANT NOTE: If you are installing an inside oil tank in the same room as the boiler, you must allow a 5 foot minimum clearance between the tank and the boiler. The oil tank should be set and installed in position **BEFORE** the boiler is installed.

Oil Tank Installation Specifications (continued)

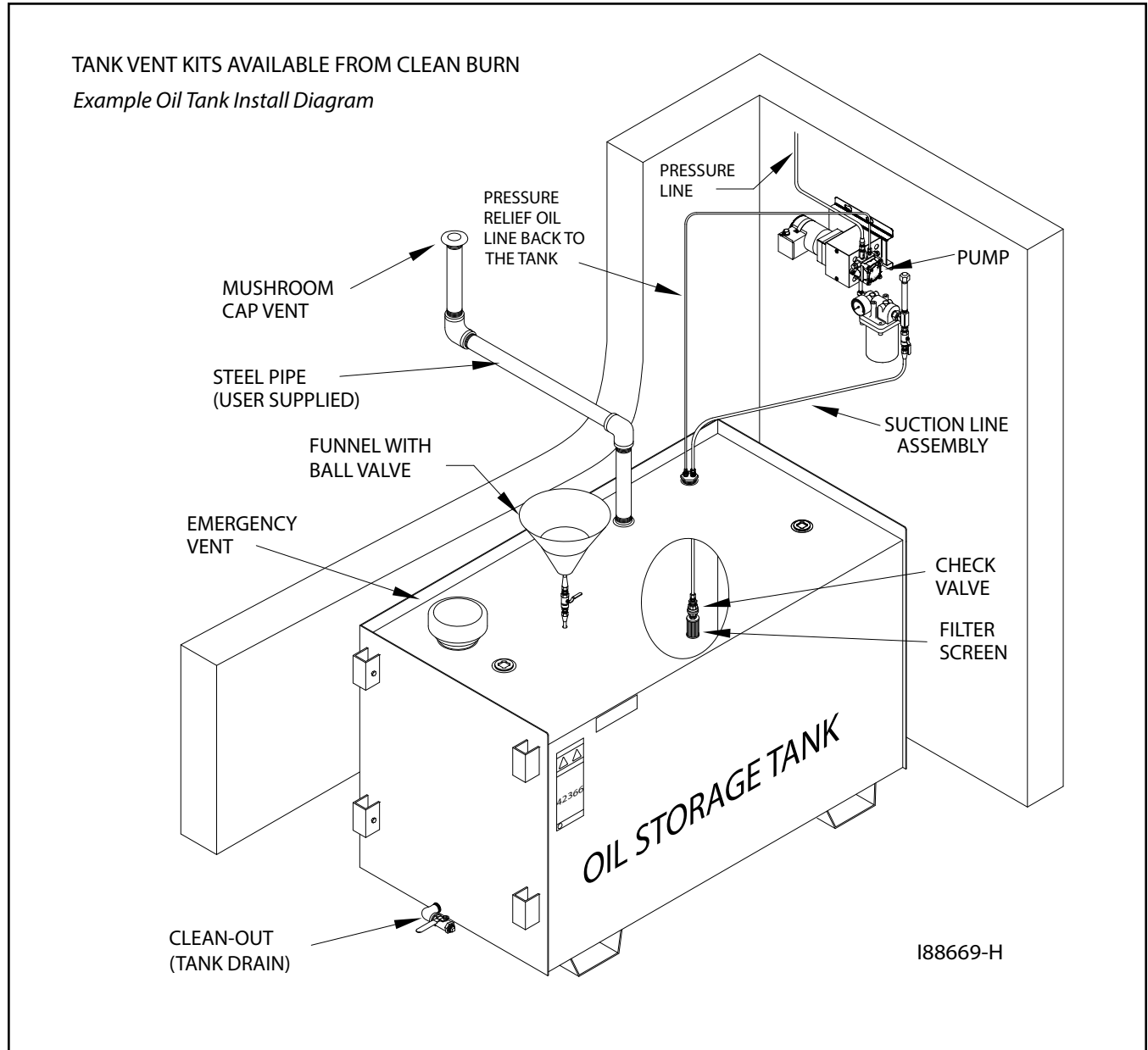

Figure 4D - Typical Metering Pump Installation with Inside Tank

Installing the Tank Vent and Emergency Vent

Some codes require that you install a tank vent (to the outside) and an emergency vent for your tank as shown in Figure 4D. **Tank Vent Kits** are available from Clean Burn; contact your local Clean Burn dealer to order. Be sure to check your local codes for any additional tank installation requirements, and adhere to the following installation guidelines:

- Install a length of minimum 2" steel pipe (user-supplied) terminating outside with a proper vent cap as shown in Figure 4D. Consult local codes for information and requirements concerning the proper venting of oil storage tanks.
- Install an emergency vent as shown in Figure 4D. Contact your tank manufacturer for information concerning the proper emergency vent for your tank.

Installing the Metering Pump

Preparing for Installation

Before starting installation of the metering pump, review Figures 4E, 4F, and 4G to become familiar with the metering pump components. You will also need to accomplish the following activities:

- Verify that you have the proper metering pump for your boiler (note the specific gear motor part numbers shown in Figure 4F).
- Gather all required tools and materials as needed for installation; as indicated in the following procedures, some materials (e.g. fittings, tubing) are to be user-supplied.
- *Standard mounting* is vertical mounting on a wall; **this pump installation is recommended.** *Alternate mounting* is horizontal mounting on a bracket. Be sure to carefully follow the appropriate procedures/diagrams for pump mounting.
- For optimal metering pump functioning, mount the pump at a distance from the oil tank that will comply with the following requirements:
The suction oil line may NOT exceed **6 feet TOTAL vertical lift AND 4 feet TOTAL horizontal lift.**

Standard Mounting: Vertical Positioning

1. Refer to Figures 4E, 4F, and 4G. Note that the metering pump is shipped with the pump head already positioned for the standard vertical wall mounting.
2. Use the appropriate type of bolts and washers (user-supplied) to securely mount the metering pump to the appropriate wall in your building at a distance from the tank that complies with the suction oil line requirements.

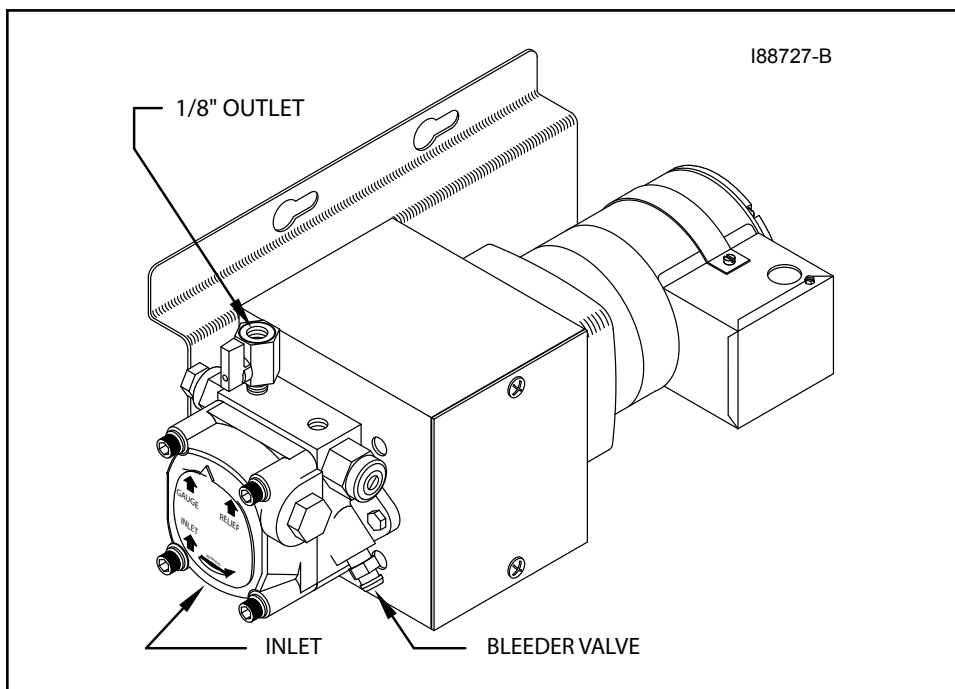

Figure 4E - Standard (Recommended) Vertical Mounting of the Metering Pump

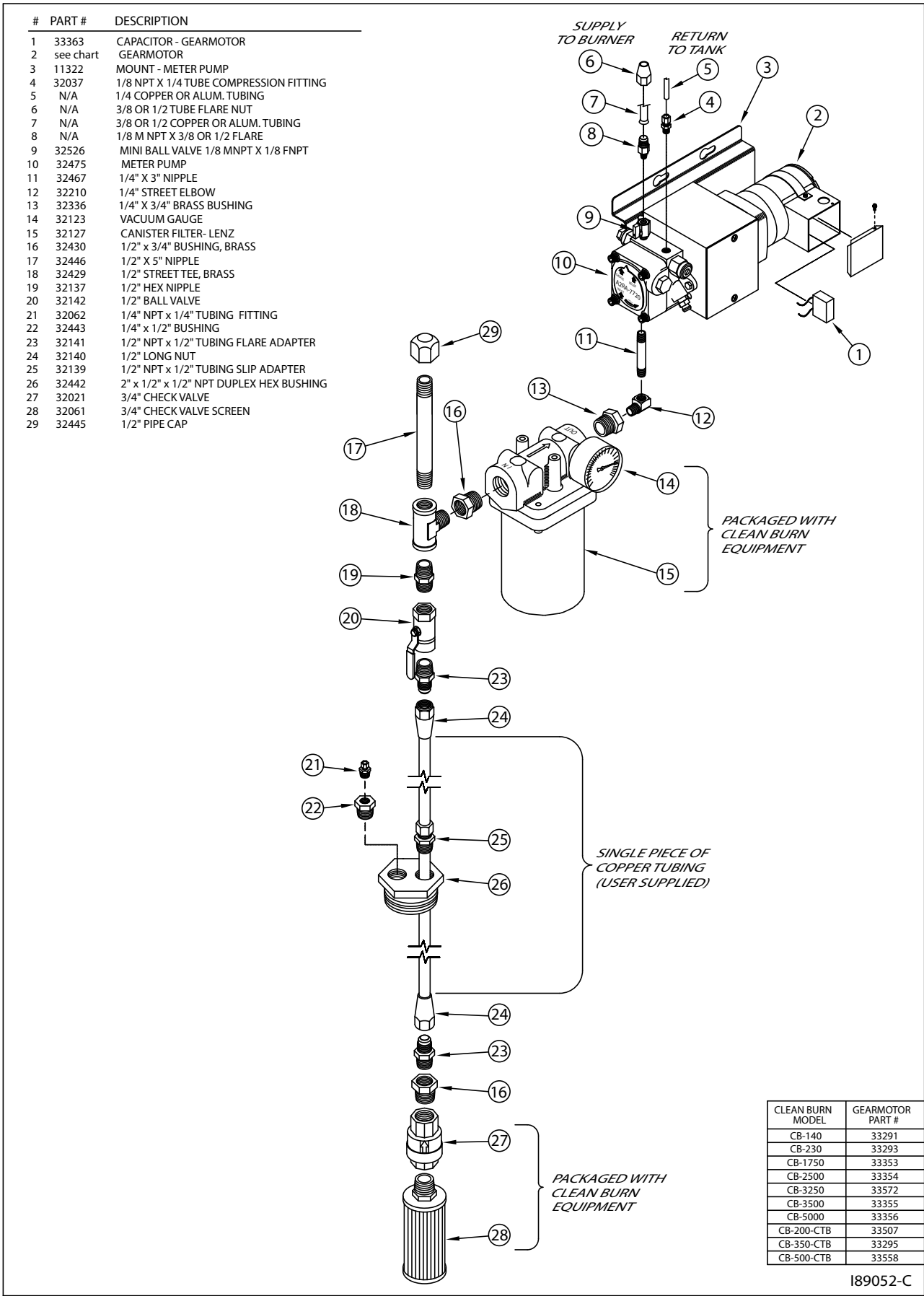

Figure 4F - Metering Pump Component Detail

Alternate Mounting: Horizontal Positioning

ATTENTION: If the metering pump is to be mounted horizontally or on a bracket as shown in Figure 4G, the pump head must be rotated counterclockwise so that it is aligned in a horizontal position. *The gauge arrow on the pump head must point up, or the pump will not prime.*

1. Refer to Figures 4F and 4G.
2. Remove the two pump mounting bolts. The coupling is keyed and does not have set screws.
3. Rotate the pump head 180 degrees to the horizontal position as shown in Figure 4G.
4. Re-install and tighten the two pump mounting bolts.
5. Use the appropriate type of bolts and washers (user-supplied) to securely mount the metering pump to the mounting bracket, which is to be installed on the appropriate wall in your building at a distance from the tank that complies with the suction oil line requirements.

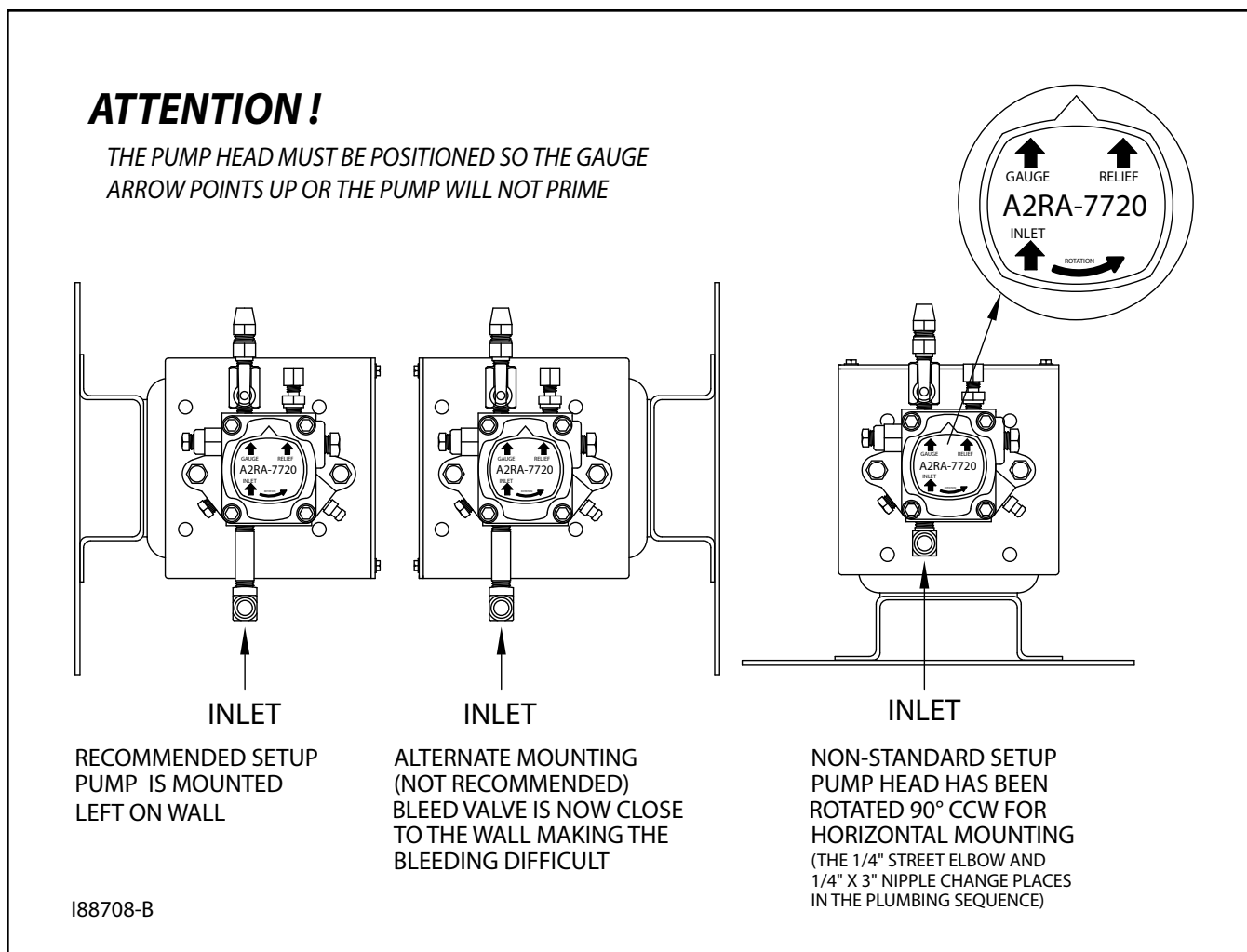

Figure 4G - Proper Positioning of Metering Pump Head

Connecting Water to the Coil Tube Boiler

IMPORTANT NOTE! Detailed information on the installation and operation of the hydronics system is provided in Section 10 of this manual. The instructions provided here are abbreviated and serve only to indicate *when* these procedures should be performed; consult Section 10 for the detailed version.

NOTE: PLUMBING ASSEMBLY IS SHIPPED DRY FIT ONLY. DO NOT INSTALL UNTIL PLUMBING COMPONENTS ARE RE-ASSEMBLED WITH PROPER THREAD SEALANT.

1. Connect the desired header supply and return lines to the CTB.
2. Have the water trim installed by a certified hydronics technician according to the ASME Section IV Boiler Code. Heat exchangers must be used for domestic water heater installations.
3. For air separation and elimination, Clean Burn recommends the Enhanced Spiral-Type Air Separator which can be supplied by your local Clean Burn dealer. Installing an air separator helps ensure that air is purged from the boiler, which is necessary for optimal startup and operation of the burner.
4. The relief valve discharge must be piped to within four inches of the floor or to a floor drain. Be sure to allow for clearance to remove the back panel for servicing.

Filling the Coil Tube Boiler with Water

ATTENTION: *It is necessary to fill the CTB with water prior to wiring and turning the CTB ON.* The boiler circulator bearings are water lubricated and should not be allowed to operate dry. Filling the CTB with water provides immediate lubrication of the bearings. Purging air from the water is also critical; doing so enables proper startup of the burner.

1. Fill the CTB with clean tap water.
ATTENTION: To prevent damage to the CTB, DO NOT fill the boiler with water when the boiler is hot.
2. The pressure gauge should read 20 psig. (If a different operating pressure is needed, contact the Clean Burn Service Department for additional instructions.)
3. **Refer to Section 10, The CTB Hydronic System, for additional information.**

Installing the Suction Oil Line Components

ATTENTION: It is critical that you adhere to the following specifications for suction oil line installation (*oil line from the tank to the pump*). If these specifications are not met, the metering pump will not function correctly and the burner will shut down on reset. The majority of service problems with the metering pump are caused by leaks at fittings in the suction oil line; these problems are eliminated by ensuring a 100% airtight suction oil line which slants up to the pump.

- All suction oil line components must be installed as shown in Figures 4A, 4B, and 4F. **Suction line size is 1/2" diameter.** Proper installation allows the suction oil line to be filled with used oil during initial priming.
- The suction oil line may NOT exceed **6 feet TOTAL vertical lift AND 4 feet TOTAL horizontal lift** (*which equals 6.0" hg maximum operating vacuum*). To determine if your suction oil line will meet this specification for maximum operating vacuum, base the calculation for your installation on the following equivalents:

(1) vertical foot = 0.75" hg (vacuum)

(4) horizontal feet = 0.75" hg (vacuum)

NOTE: ALSO ADD 0.75" hg to the final sum to account for every oil filter, shut-off valve, and check valve on the suction side of the pump assembly.

Sample calculation: (6) vertical feet x 0.75" = 4.50" hg AND (4) horizontal feet = 0.75" hg
4.50" hg + 0.75" hg + 0.75" hg = 6.00" hg vacuum

- The metering pump must be installed with a **3/4" check valve and screen** at the end of the suction oil line, or the pump will not maintain its prime.
 - Use **Permatex #2 non-hardening gasket sealer** on every threaded fitting. DO NOT use teflon tape or teflon pipe dope compounds; the teflon can flake off and cause damage to the pump head.
 - **The suction oil line must be 100% airtight for proper system functioning.** Use only high-quality flare fittings for the copper tubing. DO NOT use compression fittings. DO NOT use any steel pipe unions. DO NOT use sweat copper pipe. These types of fittings cause air leaks in the suction oil line and will require re-installation.
 - **The suction oil line must slant up to the pump;** any high spots will trap air and will not allow the pump to prime.
1. **Assemble the suction oil line fittings (*from the metering pump to the canister filter*):**
 - a. Refer to Figure 4F for a detailed look at the metering pump components and fittings.
 - b. Remove the plug from the 1/4" inlet port of the pump.
 - c. Install the 1/4" x 3" brass nipple into the 1/4" inlet port on the pump.
 - d. Install the 1/4" brass street elbow onto the 3" brass nipple; turn the fitting onto the nipple until it is tight and faces away from the pump mounting plate.
 - e. Prepare the canister filter for installation:
 - Install the 3/4" x 1/4" brass hex bushing into the outlet port of the canister filter.
Check the direction of the arrow for the proper flow.
 - Install the 3/4" x 1/2" brass bushing into the inlet port of the canister filter.

Installing the Suction Oil Line Components (continued)

- (e.) Prepare the canister filter for installation (*continued*):
- Remove the plug from one of the 1/8" gauge ports in the canister filter and install the vacuum gauge. Seal the threads of the gauge with Permatex #2 non-hardening gasket sealer.
 - Install the 1/2" threaded pipe adapter into one side of the 1/2" ball valve.
 - Install the 1/2" MPT x 1/2" flare adapter into the other side of the ball valve.
 - Install this assembly into one side of the 1/2" brass tee.
 - Install the assembled 1/2" tee into the 3/4" x 1/2" brass bushing, which is installed in the inlet port of the canister filter. Make sure that the 1/2" flare adapter is pointing down.
 - Install the canister filter assembly onto the 1/4" brass street elbow as shown in Figure 4E. The canister filter must be installed with the arrow pointing towards the pump (direction of oil flow).
 - Install the 1/2" x 5" brass nipple into the top side of the 1/2" brass tee assembly.
 - Loosely install the 1/2" brass cap onto this nipple. DO NOT tighten the cap at this time.

2. **Install the suction oil line (from the the tank to the canister filter):**

- a. Refer to Figures 4A, 4B, and/or 4F.
- b. Prepare a piece of 1/2" O.D. copper tubing (user-supplied) which will function as the pick-up line from the tank to the canister filter. This copper tubing must have the following specifications:
 - The tube must be one continuous piece of 1/2" O.D. copper tubing with no kinks or fittings.
 - The tube is to slant up from the tank to the pump with no loops or high points to trap air.
- c. Locate the 2" MPT x 1/2" FPT x 1/2" FPT duplex, slip-thru hex bushing (which will eventually be installed into one of the 2" openings on the tank). *Note that the fitting is marked "S" for suction and "R" for return.*
- d. Install the 1/2" MPT x 1/2" slip fitting into the "S" side of the 2" duplex slip-thru hex bushing.
- e. Install the 1/4" MPT x 1/4" compression fitting into the 1/2" x 1/4" brass bushing.
- f. Install the 1/2" x 1/4" brass bushing into the "R" side of the 2" duplex slip-thru hex bushing.
- g. Measure the height of the oil tank (from the bottom of the tank, NOT the floor) to the 2" opening that you are going to use for the supply oil line. Deduct 12" (305mm) from this measurement and transfer this new measurement onto the 1/2" O.D. copper tubing.
- h. Remove the locking nut and ferrel sleeve connector from the 1/2" slip fitting, and slide them over the copper tubing.
- i. Slide the 1/2" O.D. copper tubing through the 1/2" slip fitting, which is installed in the "S" side of the 2" hex bushing.
- j. Install the screen into one side of the 3/4" check valve (making sure the arrow is pointing away from the screen assembly).
- k. Install the 3/4" x 1/2" brass bushing into the 3/4" check valve.
- l. Install the 1/2" MPT x 1/2" flare adapter into the 3/4" x 1/2" brass bushing.

Installing the Suction Oil Line Components (continued)

- (2.) **Install the suction oil line (*continued*):**
- m. Slide the 1/2" flare nut over the end of the 1/2" copper tubing, and flare the end of the tubing.
NOTE: Use a high-quality flaring tool (such as a Ridgid Flaring Tool) to ensure that all flares are made properly (i.e. so they will be 100% airtight).
 - n. Install the flared oil line and nut onto the assembled check valve/screen and tighten.
 - o. Pick up the assembled oil line, and carefully guide the end of the tubing with the check valve through the 2" tank opening.
 - p. Apply Permatex #2 non-hardening gasket sealer (or equivalent) to the threads of the 2" duplex slip-thru tank bushing, and tighten this fitting into the tank.
 - q. Pull the 1/2" copper tubing back up through the slip fitting until you see the mark that you put on the tubing earlier. Holding the tubing with one hand, push the ferrel sleeve connector and locking nut down the tubing, then tighten onto the 1/2" slip fitting. The oil line is now installed in the correct position off of the bottom of the tank.
 - r. Carefully bend the oil line up to the canister filter; use a spring bender over the oil line while bending the tubing to prevent kinks in the oil line. Allowing for the flare nut, cut off the excess tubing.
 - s. Install the 1/2" flare nut onto the tubing, and flare the end of the tubing.
 - t. Install the end of the tubing with the flare nut onto the 1/2" flare adapter (on the ball valve assembly at the canister filter).
 - u. Install a vent from the tank to the outside of the building according to code. The tank must be properly vented to allow air to enter the tank as oil is pumped out and to safely vent fumes to the outside. See Figures 4A, 4B, and 4D.
 - v. Install plugs in all other tank openings as required by code.
 - w. Inspect the installation. For proper suction oil line operation, make sure all components are installed and positioned as specified in this manual.

Installing the Pressure Relief Oil Line Back to the Tank

ATTENTION: It is critical that you adhere to the following specifications for plumbing the pressure relief back to the tank.

The metering pump requires the installation of a pressure relief oil line back to the tank that you are pulling oil from as shown in Figures 4A, 4B, and 4D.

- The **pressure relief** will open and relieve pressure if there is a restriction in the pressure oil line, clogged nozzle, etc.

Be sure to use Permatex #2 non-hardening gasket sealer to seal every threaded fitting. DO NOT use teflon tape or teflon pipe dope compounds.

1. Refer to Figure 4H.
2. Remove the plug from the relief port on top of the metering pump head.
3. Install the 1/8 NPT x 1/4 tube compression fitting in the relief port on top of the metering pump head.
4. Install 1/4" O.D. copper tubing (user-supplied) from the pressure relief port back to the oil tank. Refer to Figure 4D as needed.

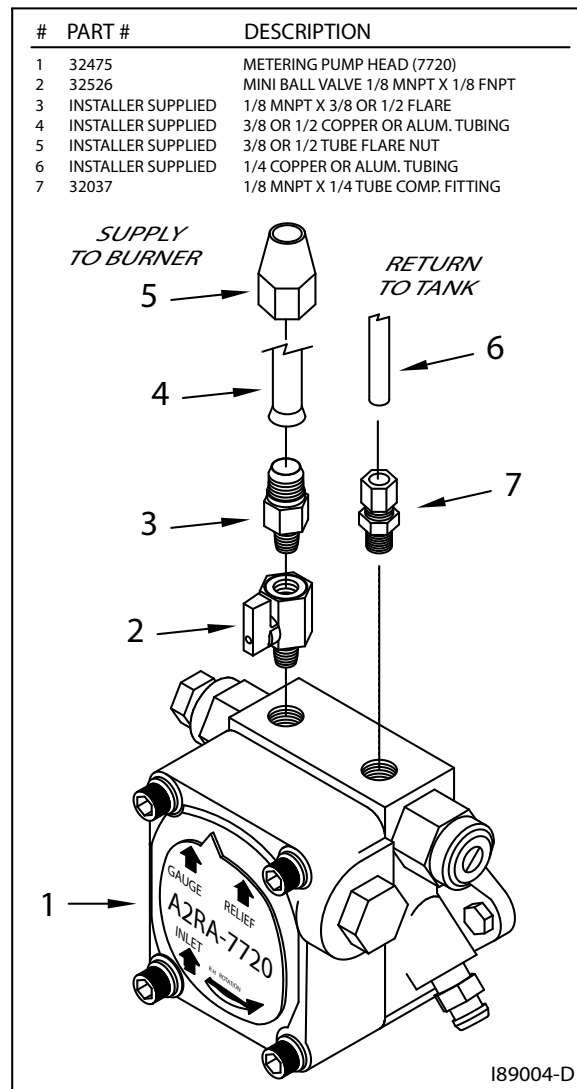

Figure 4H - Pressure Relief Oil Line Back to the Tank

Installing the Pressure Oil Line Components

ATTENTION: It is critical that you adhere to the following specifications for pressure oil line installation (oil line from the pump to the boiler); if these specifications are not met, the metering pump will not function correctly and the burner will shut down on reset.

- The parameters for pressure oil line installation are:

<u>Length of Pressure Line</u>	<u>Line Size</u>
Up to 100 feet (Please note that some installations will allow for a greater pressure line length. Contact your Authorized Clean Burn Distributor for more information.)	3/8" O.D. copper or aluminum tubing
 - **If possible, the pressure oil line should slant up to the burner** with no loops or high points to trap air.
 - Local codes may require the installation of an in-line "**Fire-O-Matic**" safety valve. Be sure to check all appropriate codes to ensure compliance.
1. Refer to Figures 4A, 4B, and 4F.
 2. Make sure you have purchased all the necessary fittings to complete the installation correctly.
 3. Install the fittings and components as shown in the related illustrations. Be sure to use Permatex #2 non-hardening gasket sealer to seal every threaded fitting. **DO NOT** use teflon tape or teflon pipe dope compounds.

Installing the Compressed Air Line

NOTE: Your air compressor system must supply air pressure to the boiler with the following requirements: **25 psi** and **water trap or dryer**. If you do not have shop air, an optional air compressor is available. Contact your local Clean Burn dealer for more information.

1. Run a compressed air line from your shop air to the burner on the boiler. Use minimum 1/4" O.D. copper tubing or equivalent for the compressed air line.
2. Install an easily accessible shut-off valve in the air line so the burner can be serviced without shutting off the shop air in your service area.
3. Install a pressure regulator (additional to the burner air regulator) in the air line, and set it at 50 psi. **ATTENTION:** DO NOT feed full shop air pressure to the burner or damage to burner components may occur.
4. Install a water trap or extractor/dryer in the air line with an automatic drain so compressed air (rather than water) is supplied to the burner. **ATTENTION:** Water must not be fed to the burner, or the flame will be extinguished and the burner will shut down. Be sure to drain water from your compressor tank on a regular basis to keep water out of the air line.

Wiring the Coil Tube Boiler



WARNING: To avoid electrical shock, make sure that power to the CTB is turned OFF before connecting any wires. All wiring must be in accordance with the National Electrical Code and local codes. Properly size all wires and use Greenfield or Thin-wall Conduit for all electrical lines. Refer to **Figures 4A/4B** at the beginning of this chapter for the Clean Burn recommended typical CTB installation. Specific wiring schematics are provided in **Appendix B** at the back of this manual.

Wiring your boiler requires the installation of the following lines/circuits:

- (1) A dedicated electrical line to the CTB (see IMPORTANT NOTE below)
- (2) A pump electrical circuit from the CTB to the oil pump (see IMPORTANT NOTE below)
- (3) A separate circuit for the load loop circulator

IMPORTANT NOTE: Separate, dedicated lines/circuits must be wired *for each boiler* in the dual-stacked unit.

Wiring to the Coil Tube Boiler

1. Install a dedicated electrical circuit to the electrical junction box on the CTB. Note that a dual-stacked boiler will require two circuits, each with a single pole, single throw breaker.



CAUTION: DO NOT tie into an existing circuit or electrical overload may occur.

2. Wire the CTB according to the Wiring Schematic in Appendix B. Refer to NFPA-70 for wire size and distances.
3. Check for correct voltage at the CTB and refer to the following chart. Incorrect voltage may damage the CTB components.

Model	Voltage	Breaker Qty. & Size*	Phase	Hertz
CB-200-CTB (single)	110/120	(1) @ 15 amps	Single	60
Dual-Stacked (200-CTB)	110/120	(2) @ 15 amps	Single	60
CB-350-CTB (single)	110/120	(1) @ 20 amps	Single	60
Dual-Stacked (350-CTB)	110/120	(2) @ 20 amps	Single	60
CB-500-CTB (single)	110/120	(1) @ 20 amps	Single	60
Dual-Stacked (500-CTB)	110/120	(2) @ 20 amps	Single	60

***NOTE: Breaker size with optional equipment is 30 amps.** When installing any optional equipment (e.g. air compressor), you must use a 30 amp breaker. Make sure a qualified electrician properly sizes and installs this electrical circuit. Refer to NFPA-70 for wire size and distances.



CAUTION: DO NOT turn on main power until instructed to do so.

Wiring to the Oil Pump

ATTENTION: DO NOT wire the oil pump directly into your building's electrical system. The oil pump must be activated (receive power from) the burner via the pump electrical circuit.

1. Install the oil pump electrical circuit from the CTB to the oil pump location (refer to Figures 4A/4B).
2. Wire the oil pump circuit according to the wiring schematic provided (Appendix B).

Wiring the Load Loop Circulator

NOTE: To reduce the amount of cold water returned to the boiler (and to protect the boiler from thermal shock), an optional circulator aquastat can be supplied by your Clean Burn Dealer.

1. Refer to the related information and illustrations in Section 10 and the CTB Wiring Diagram in Appendix B to locate and understand the wiring for the load loop circulator.
2. The cold water return in your CTB system installation should not be below 140 °F.
NOTE: For installations where cold water return is a risk, Clean Burn recommends installation of a blending loop. If a blending loop is installed in your CTB system, the load loop circulator should be wired separately from the CTB control box. Refer to Section 10 for additional information.

Installing the Stack



WARNING: Inappropriate stack materials or improper stack design/installation can adversely affect the proper, safe operation of your coil tube boiler.

Stack designs are generally classified as follows:

- (1) "Class A" stack through the ceiling of the building
- (2) "Class A" stack through the sidewall and up the side of the building

Figure 4I illustrates the through-the-ceiling stack design for a single boiler; this stack design is preferable and is more commonly used. Refer to Figure 4J for the dual-stacked boiler stack design.

When designing your stack, adhere to the following specifications:

- Models CB-200-CTB and CB-350-CTB single boilers require 8" I.D. stack components.
- Model CB-500-CTB single boilers require 10" I.D. stack components.
- Models CB-200-CTB and CB-350-CTB dual-stacked units require 8" I.D. stack components run as two (2) individual stacks.
- Model CB-500-CTB dual-stacked units require 10" I.D. stack components run as two (2) individual stacks.
- *Ensure that the vertical stack height is at least 10 feet.* If needed, increase the vertical length of the stack or install a draft inducer to obtain -.02" W.C. draft over fire. (Section 8 contains details on adjusting the draft.)
- *Keep the horizontal stack run as short as possible;* slant it upward at a minimum of 1/4" per foot of run.
- *Keep the stack design simple.* Complicated stacks (with long runs and many turns) reduce draft and result in poor burner performance. Your stack may include only one 90 degree turn. All other stack turns must be at 45 degrees or less to ensure optimal draft and burner performance.

NOTE: If you plan to use an existing masonry chimney, the chimney must be lined and be located inside the building. Exterior masonry chimneys chill the stack gases and result in poor draft and poor burner performance.

ATTENTION: *If you have an exhaust fan(s) in your shop, it is critical that you have adequate make up air (source of fresh air to replace the stale air exhausted by the fan).* When an exhaust fan is run without adequate make up air, the resultant vacuum in the building will draw combustion products back into the burner. This back draft causes poor burner performance and may damage vital burner components. Refer to Section 8 in this manual for additional information concerning exhaust fans and proper make up air.

Stack components should be installed in the following order:

- (1) Inside stack (the stack components from the coil tube boiler breach to within 18" of the ceiling, roof, or sidewall of your building)
- (2) Barometric damper(s)
- (3) "Class A" stack penetration through the ceiling, roof, or sidewall
- (4) "Class A" stack on the exterior of the building
- (5) "Class A" stack cap

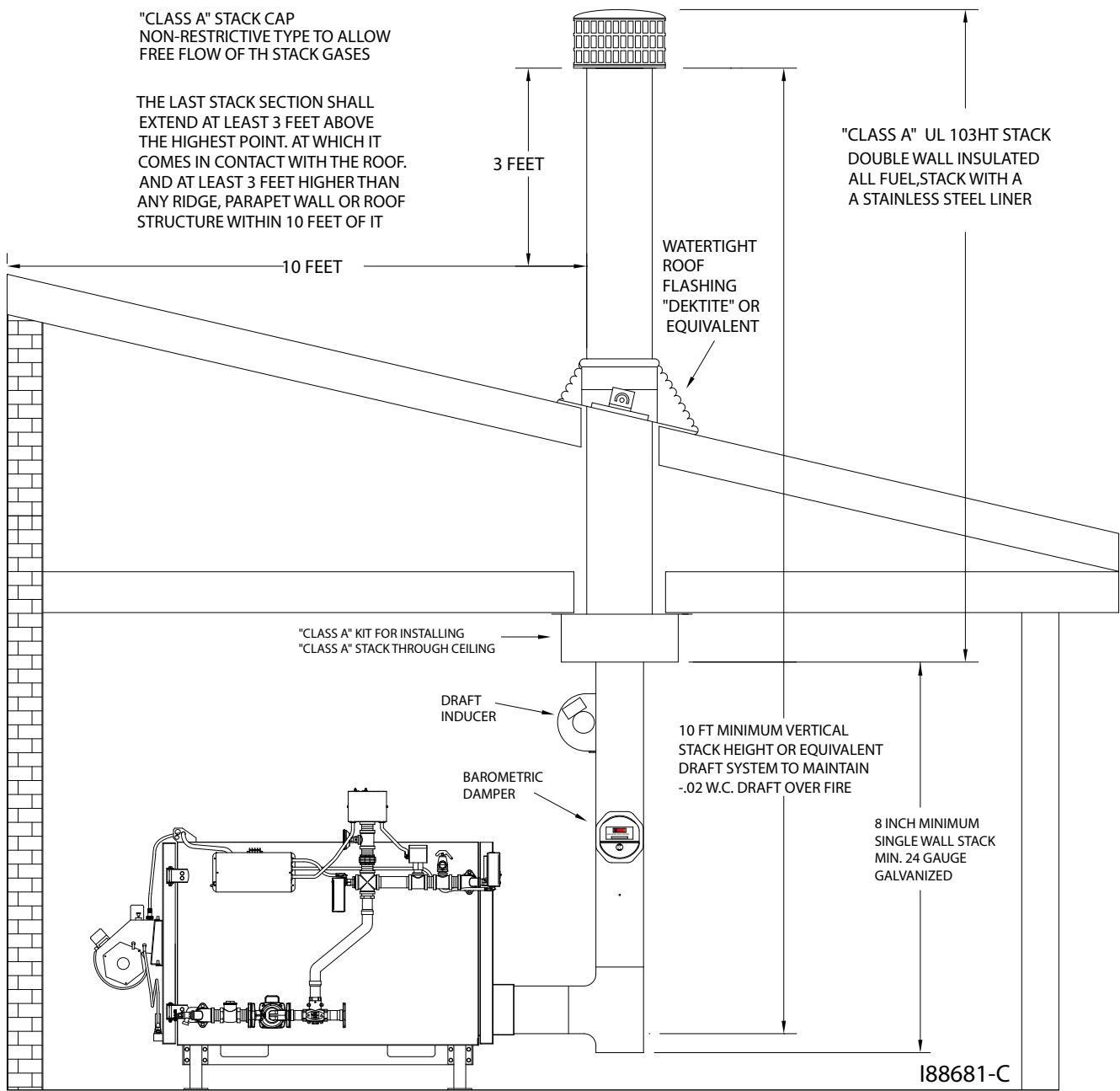

Figure 4I - Installation of "Class A" Stack Through Roof/Ceiling (Single Boiler)

Installing the Interior Stack



CAUTION: Single wall stack components may be used *only* for those portions of the stack which are located inside your building and away from any fire/burn hazards.

1. The stack can be installed from either side of the smoke hood breach. Install the 8" smoke cap onto the unused smoke hood breach ring assembly.
2. Install a piece of the single-wall 24-gauge galvanized stack (minimum 18" in length) onto the smoke hood breach.

Installing the Stack (continued)

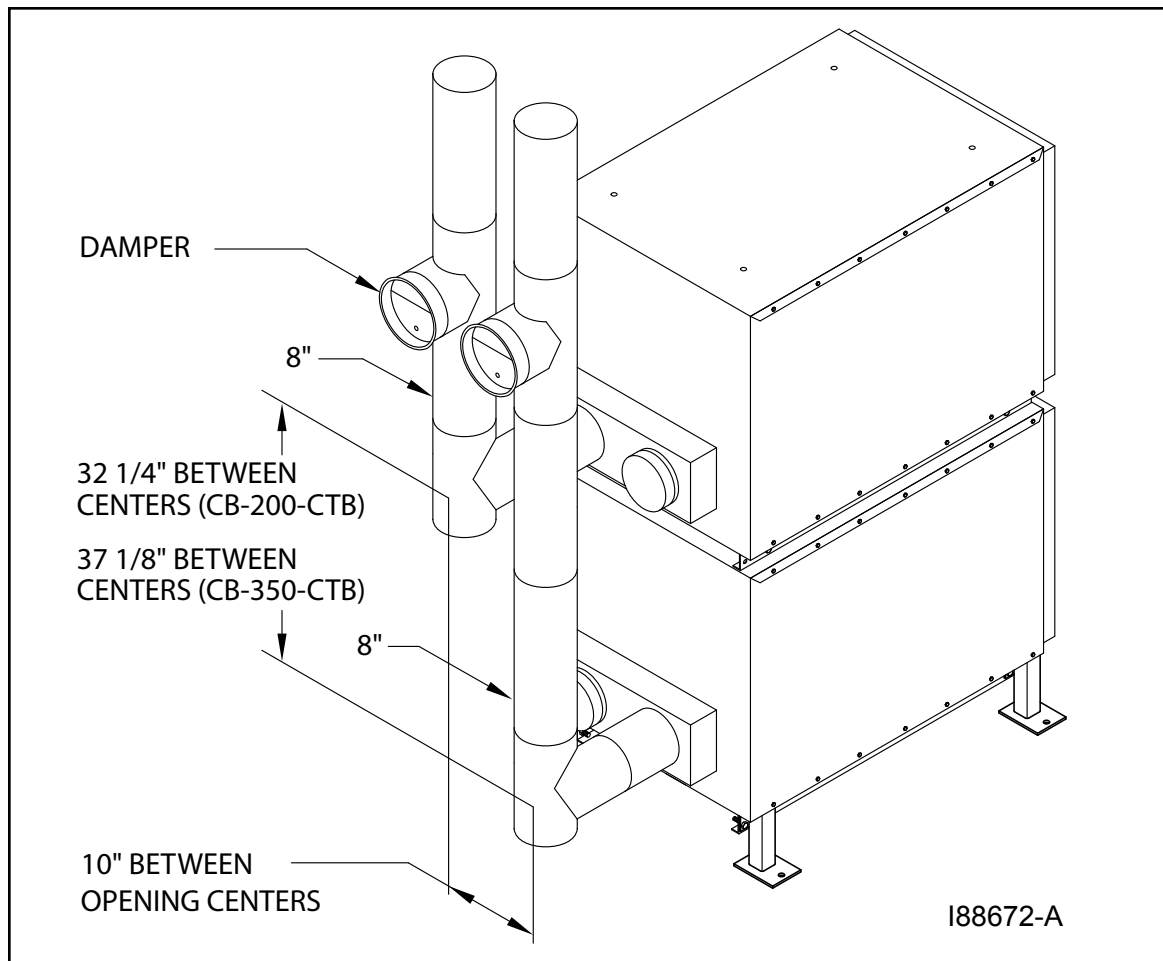

Figure 4J - Detail of Dual-Stacked Boiler Stack Installation

3. Install an elbow or clean-out tee (with a smoke cap installed in the bottom) onto the extension piece from the boiler smoke hood breach.
4. Install a smoke pipe tee onto this elbow or clean-out tee (for the installation of the barometric damper).

ATTENTION: Avoid additional 90-degree turns in the stack. Each additional 90-degree turn slows down stack gases, creates back-pressure, and results in repeated burner shutdown and unnecessary service calls. All other turns in the stack should be at a 45-degree (or smaller) angle.

Installing the Barometric Damper(s)

1. Refer to Figure 4K. Install a single wall tee (min. 24 gauge) on the first straight vertical or horizontal stack section within three feet of the CTB breach.
NOTE: This tee is required to support the barometric damper. You must purchase this tee when you purchase your stack materials (8" single wall tee - CB# 70174; 10" single wall tee - CB# 70180).
ATTENTION: For Dual-Stacked CTB Units Only - You are required by code to install two dampers (provided) - one for each boiler. DO NOT attempt to substitute other types of dampers--they will not allow the unit to function properly and may void your warranty.

Installing the Stack (continued)

2. **For CB-500-CTB ONLY:** Install the 9"-to-10" pipe adapter in the opening of the tee as shown in Figure 4K.
3. Install the barometric damper in the opening of the tee (or pipe adapter for CB-500-CTB). Use a small spirit level to make sure that it is properly level.
3. Install two self-tapping screws as shown in Figure 4K (i.e. one on each side of the barometric damper) to hold the damper in place. **DO NOT** install a screw at the bottom of the barometric damper, or the flapper of the damper will not operate correctly.

NOTE: Specifications for adjusting the barometric damper for proper draft overfire are provided in **Section 8** of this manual.

9" CLEAN BURN BAROMETRIC DAMPER WITH ADAPTOR IN 10" SINGLE WALL TEE

188547

(FOR CB-500-CTB)

2	1	31198	DAMPER PIPE ADAPTOR
1	1	31197	9" BAROMETRIC DAMPER
No	QTY	PART #	DESCRIPTION

8" CLEAN BURN BAROMETRIC DAMPER INSTALLED IN SINGLE WALL TEE

188539

(FOR CB-200-CTB and CB-350-CTB)

1	1	31170	8" BAROMETRIC DAMPER
No	QTY	PART #	DESCRIPTION

Figure 4K - Installation of Barometric Damper

Installing the Stack Safety Switch For Canadian Installations

NOTE: CSA Standards require that all heating equipment must be installed with a stack safety switch. If your heating equipment is being installed in Canada, follow the instructions listed below.



CAUTION: For your safety and the safe operation of your heating equipment, the stack switch must be installed by a qualified installer in accordance with the installation instructions provided here. Wiring must be accomplished in accordance with all applicable codes. Failure to adhere to these safety recommendations may result in serious personal injury and/or equipment damage.

1. Follow the instructions in the *Operator's Manual, Section 4* to install a proper stack, including the barometric damper which must be installed within 40 inches of the breach.
NOTE: The barometric damper must be installed so that it is level and the flapper moves freely.
2. Ensure that main power to the heating equipment is turned OFF.
3. Position the stack safety switch over the lip of the barometric damper as shown in Figure 4L.
4. Drill a 1/8" pilot hole for the mounting screw, and mount the stack safety switch using the mounting screw supplied with the switch.
NOTE: The mounting screw must not interfere with the free movement of the flapper on the barometric damper.
5. Install the wall thermostat according to the instructions provided in the *Operator's Manual, Section 4*. Wire the wall thermostat and stack safety switch in series as shown in Figure 4M. Install the wire so that it is secured away from any hot surfaces.
6. When the heating equipment installation is completed, follow the instructions in the *Operator's Manual, Sections 5 and 6* to prime the pump and start/adjust the burner.
7. Follow instructions in the *Operator's Manual, Section 8* to check the draft; this is crucial for the proper, safe operation of the heating equipment.

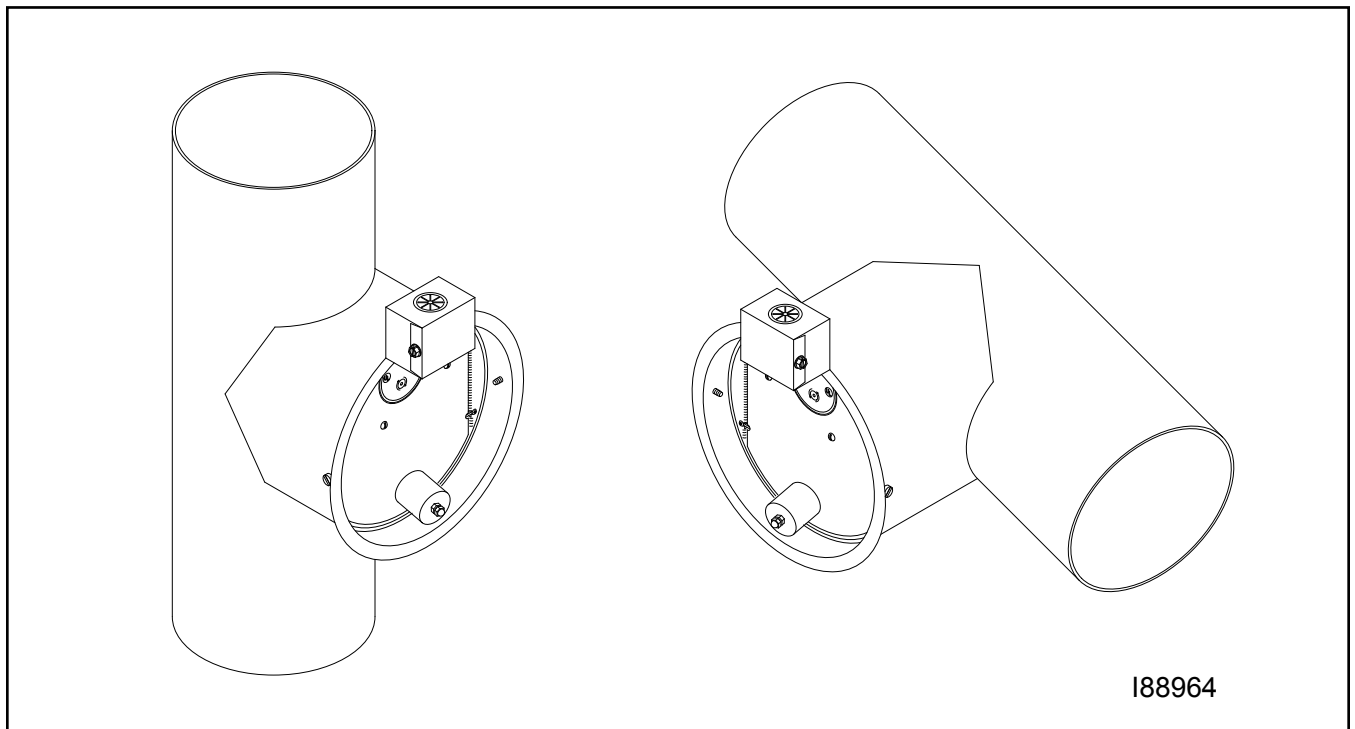

Figure 4L - Stack Safety Switch Installed on the Barometric Damper

Resetting the Stack Safety Switch

WARNING: BURN HAZARD! To prevent serious personal injury, be sure to allow ample time, at least 30 minutes, for the stack, barometric damper, and switch to cool down before attempting to access and service these components. It is crucial to identify the cause of the stack obstruction (e.g. heavy snowfall) and correct it *before* resetting the stack safety switch and re-starting the burner. **DO NOT operate the heating equipment with an obstructed stack;** failure to correct an obstructed stack may result in fire, explosion, and/or burn hazards causing serious personal injury or death.

NOTE: In locations where heavy snowfall occurs, it is critical that the stack remain unobstructed by snow. For safe heating equipment operation, be sure to keep the area surrounding the stack clear of snow.

1. Before resetting the stack safety switch, check the stack to make sure it is clear of any obstructions.
2. Remove the cover from the stack safety switch, and push the small button in the middle of the switch.
3. Pushing the stack safety switch reset button will re-establish the thermostat circuit, and the burner will start (assuming the wall thermostat is calling for heat).

Understanding the Function of the Stack Safety Switch

The **Stack Safety Switch** monitors the temperature at the barometric damper on the stack and is designed to detect the obstruction of the free flow of stack gases from the heating equipment and shut down the burner. Obstruction of the stack results in the “spillage” of stack gases from the barometric damper, which heats up the switch. The switch then opens, disconnecting the thermostat circuit to the burner, and the burner shuts off.

Stack Safety Switch Specifications

Switching Voltage	24 volts
Switch OPEN Temperature	180 °F
Switch Type	L180, normally closed, manual reset

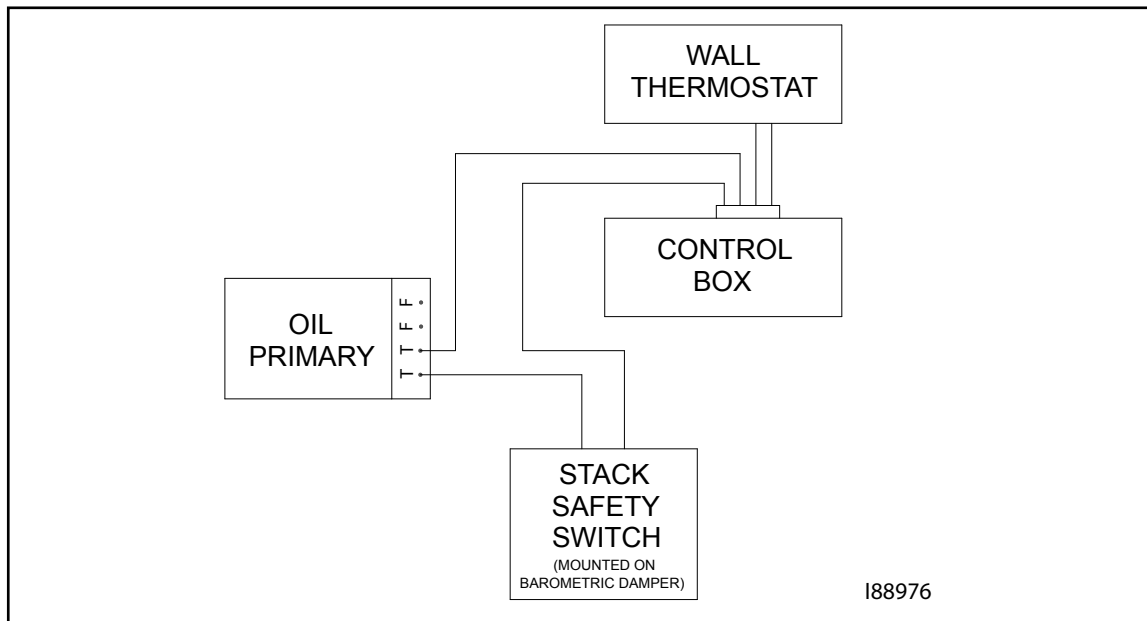

Figure 4M - Stack Safety Switch Wiring Diagram

Installing the Stack Penetration



WARNING: When running the stack through your ceiling, roof, or sidewall, you must use **Class A/UL103 HT double-wall insulated all-fuel stack components** with a stainless steel liner. **DO NOT** run single-wall stack through your ceiling, roof or sidewall.

1. Refer to Figure 4I as needed.
2. Follow the installation instructions provided by the stack manufacturer.

Installing the Exterior Stack

ATTENTION: All exterior stack pieces must be Class A/UL103 HT double-wall insulated all-fuel stack components with a stainless steel liner.

- DO NOT use Class B Vent/double-wall stack components (i.e. for gas fired appliances only).
- DO NOT use Type L Vent/double-wall stack components (for approved fuel oil appliances only).
- DO NOT use single-wall stack for your exterior stack. Single-wall exterior stack chills the stack gases and results in poor draft and poor burner performance.

1. Refer to Figure 4I as needed.
2. Follow the installation instructions provided by the stack manufacturer.
3. Install water-tight roof flashing around the penetration of the exterior stack.

NOTE: Clean Burn recommends the use of "Dektite" roof flashing (or equivalent) which ensures a water-tight seal when installed properly. Contact your local Clean Burn dealer for details.

Installing the Stack Cap

NOTE: Proper installation of a Class A/UL103 HT stack cap ensures the free flow of stack gases which is essential for optimal burner performance.

1. Refer to Figure 4I as needed. Your stack cap should be classified as: Class A/UL103 HT non-restrictive, all-fuel type.
2. Install the stack cap according to the manufacturer's instructions.

Installing the Draft Inducer

ATTENTION: The Field brand draft inducers have been tested for use on Clean Burn Equipment. **DO NOT** use other models or brands of draft inducers.

Understanding the Importance of the Draft Inducer

The draft inducer is designed to aid in the removal of the natural draft created by the appliance to vent the combustion gases to the outside of the building. As the paddle wheel turns, a negative pressure is maintained within the stack so that the combustion gases can leave the boiler and travel out of the stack. (See Figure 4N.)

Proper sizing, installation, and adjustment of the draft inducer are critical for optimal draft inducer operation.

Installing the Draft Inducer (continued)

NOTE: Lubricate the motor as recommended by the Draft Inducer manufacturer.

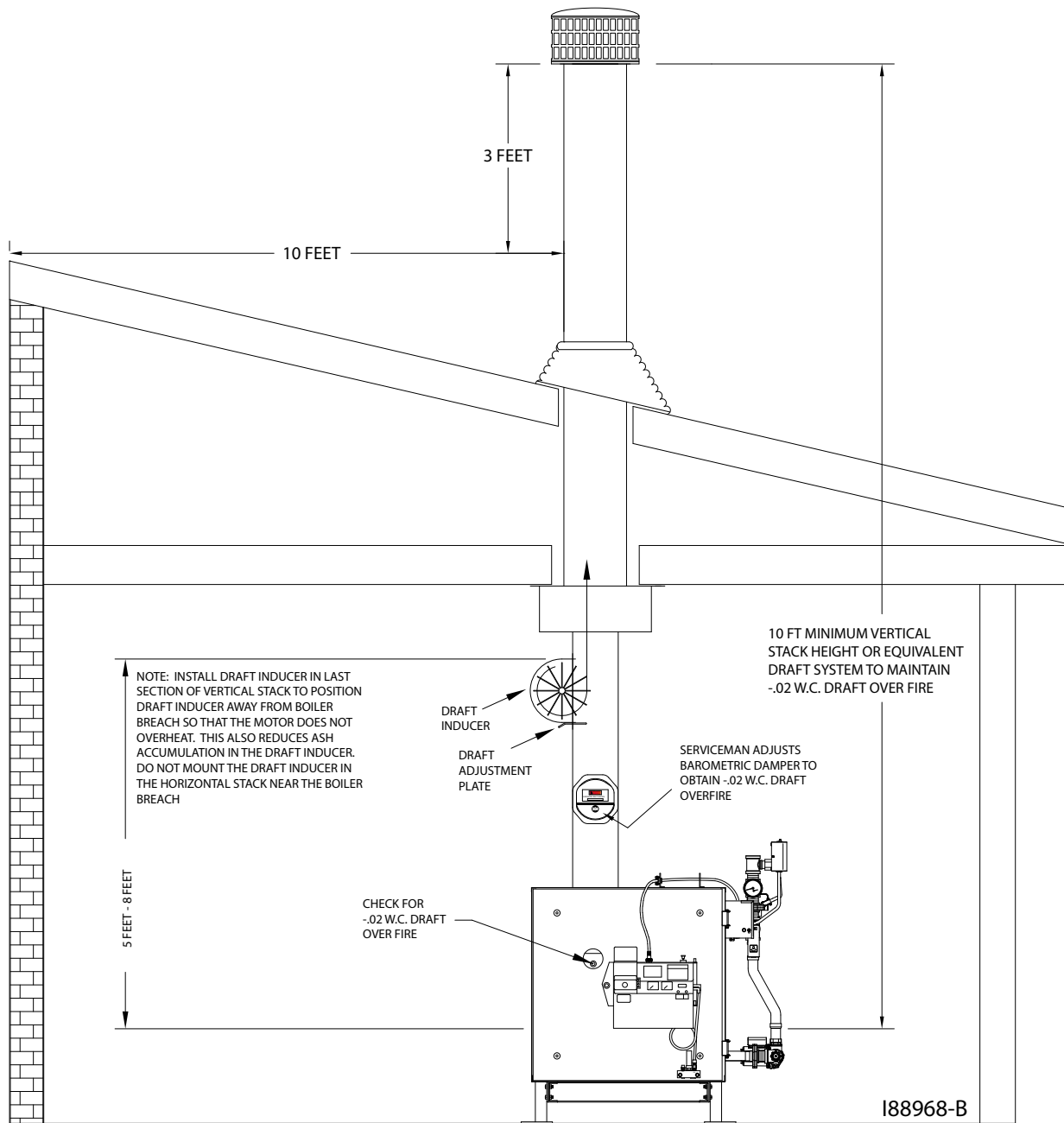

Figure 4N - Installation of the Draft Inducer

WARNING: Turn OFF the main power to the boiler before proceeding with the installation of the draft inducer.

ATTENTION: It is very important to install the draft inducer on a vertical section of stack to isolate the inducer from excessive heat and ash buildup. Never install the draft inducer on a horizontal section of stack close to the breach where heat and ash will damage the inducer motor.

Installing the Draft Inducer (continued)

1. Refer to Figure 4N. Follow the instructions included with the draft inducer to mount the draft inducer on the section of single-wall vertical stack.
2. Position the draft plate all the way out so that it does not reduce the draft produced by the draft inducer. Follow directions in **Section 8 (Adjusting the Draft Overfire)** to set the proper draft.

Wiring the Draft Inducer for Normal Operation*

*(No exhaust fans in the building)

1. Wire the draft inducer according to the **Wiring Diagram** in the **Burner Control Box** and also provided in **Appendix B** at the back of this manual.

Installing the Wall Thermostat or Aquastat

IMPORTANT NOTE: The wall thermostat is available separately from Clean Burn (i.e. it is not included with the CTB). Refer to Appendix A in this manual for additional information on remote temperature sensing controls available from Clean Burn for your CTB system installation.

1. Select a location for the thermostat on an interior wall away from any hot or cold drafts.
2. Remove the top cover from the thermostat by pushing gently on the latch at the top center of the body. *(Hold the thermostat base in one hand, and grasp the body with the other hand; push in on the latch with your thumb, and pull the cover away from the base.)*
ATTENTION: DO NOT use a screwdriver to pry the cover off the base, or damage may occur.
3. Remove the green paper insert and the black plastic battery isolator from the battery section of the thermostat.
4. Refer to the **Burner Wiring Diagram** in **Appendix B** at the back of this manual. Run two wire, 18-gauge (minimum) thermostat cable from the terminals on the back of the thermostat base to the T/T terminals of the control box on the side of the boiler. **DO NOT** run the wiring to the primary control!
5. Run two wire, 18-gauge (minimum) thermostat cable from the B1/B2 terminals of the control box on the side of the boiler to the T/T terminals of the primary control on the burner.
ATTENTION: NEVER jump between T/T terminals on the burner control box or the primary control without removing one of the wires. Failure to remove one of the wires will burn out the heat anticipator on the thermostat and will cause the thermostat to fail.
6. Mount the thermostat base 60" to 66" from the floor using the hardware provided.
7. Reassemble the thermostat body onto the base. *(Align the hinges at the bottom of the cover with the slots at the bottom of the base, and swing the cover up into place.)*

Replacing the Wall Thermostat Batteries

1. Proper battery level is indicated by the room temperature being displayed on the LCD screen.
2. When the battery level becomes low, a battery icon along with the word "REPLACE" will be displayed in the lower left corner of the LCD screen. Replace the batteries to ensure proper operation, following the previous instructions on the thermostat disassembly procedure.
3. If the batteries are not replaced, the display will slowly become dim and not display any information. The thermostat will eventually not function. If this happens, replace the batteries immediately.

Inspecting the Coil Tube Boiler Installation

Following the completion of all installation activities described in this chapter, the CTB should be inspected by qualified personnel before firing. This ensures that your installation meets all applicable national and local codes and allows for any deficiencies in the installation to be corrected before CTB startup. *Improper installation will void your warranty.*

NOTE: Important! During the inspection, be sure to **check the aquastat settings**. Initial settings are listed here:

- Operating Aquastat 180 °F (minimum)
- Hi-limit Aquastat (with manual reset) 240 °F

Refer to Section 6 for burner startup and final adjustments of the aquastat.

Any changes to these settings should be made only by a qualified hydronics technician. See Section 10, The CTB Hydronics System, for more information.

SECTION 5: METERING PUMP PRIMING

Understanding Metering Pump Priming

Preparing your Clean Burn boiler for operation begins with priming the metering pump. The procedures in this section must be performed in sequence *without interruption* to properly prime the pump.

IMPORTANT NOTE FOR DUAL-STACKED UNITS: The priming procedures will have to be performed for one burner, and then repeated for the other burner (i.e. get one burner running first before attempting priming of the other burner.)

Required Tools and Materials

The following tools and materials are required for oil pump priming and should be gathered before starting any procedures:

- 3/8" open-end wrench
- 5/8" open-end wrench
- Rags
- Two containers (minimum one-gallon)
- Permatex #2 non-hardening gasket sealer
- Adjustable Wrench
- Pipe Wrench

Priming the Metering Pump

ATTENTION: *The priming process must be done precisely as described in this procedure to ensure that all air is thoroughly bled from the system.* Failure to bleed all air from the system will result in repeated burner shutdowns on reset.

1. Refer to Figure 5A.
2. Remove the 1/4" NPT plug from the side of the pump head, and set it aside.
3. Remove the 1/2" brass cap from the 1/2" brass nipple. Place a funnel in the opening. Slowly pour used oil into the funnel **until oil comes out of the side of the pump head**; this will fill the oil line, canister filter, and pump head with oil.
ATTENTION: NEVER run the pump head dry (i.e. without oil in the pump head). Doing so will severely damage the pump.
4. Apply Permatex #2 non-hardening gasket sealer to the threads of the plug (removed from the pump head). Re-install the plug and tighten.
5. Apply Permatex #2 non-hardening gasket sealer to the threads of the 1/2" brass nipple. Re-install the 1/2" brass cap on the brass nipple and tighten.
6. Open the bleeder on the pump two to three (2-3) full turns, and position a container to catch oil which will flow from the bleeder during pump priming.
7. Close the mini ball valve at the outlet port of the pump head.
ATTENTION: Verify that the relief oil line is installed back to the tank before closing the mini ball valve. Closing the mini ball valve will cause the internal pump relief valve to open.

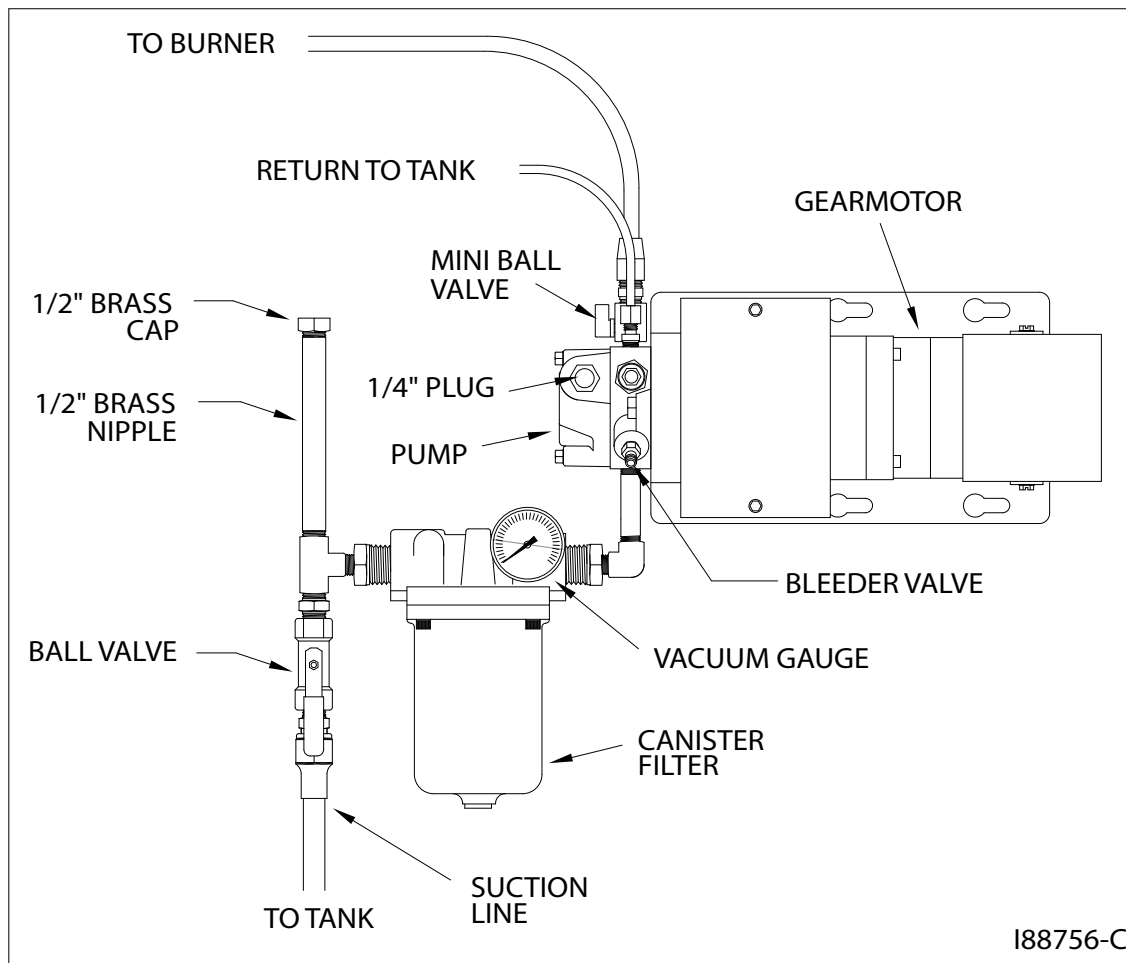

Figure 5A - Priming the Metering Pump

Priming the Metering Pump (continued)

8. Activating the Pump

NOTE: The coil tube boiler features a priming switch which is mounted on the left-hand side of the electrical junction box on the hydraulics side of the boiler cabinet. The priming switch has two positions:

- **PRIME (switch is in the UP position / orange indicator light is ON):** this is used only for pump priming. When the switch is in the UP position, the pump circuit is activated for priming. The pump will continue to run as long as the switch is in this position. The oil primary control circuit is de-activated so the burner cannot run while the switch is in the UP position.
 - **BURNER (switch is in the DOWN position):** this is used for normal burner operation. When the switch is in the DOWN position, the burner controls the operation of the pump. The pump will only run while the burner is running.
- a. Refer to Figure 5B to locate the priming switch.
 - b. Turn the priming switch to the UP position. The pump should immediately start running.

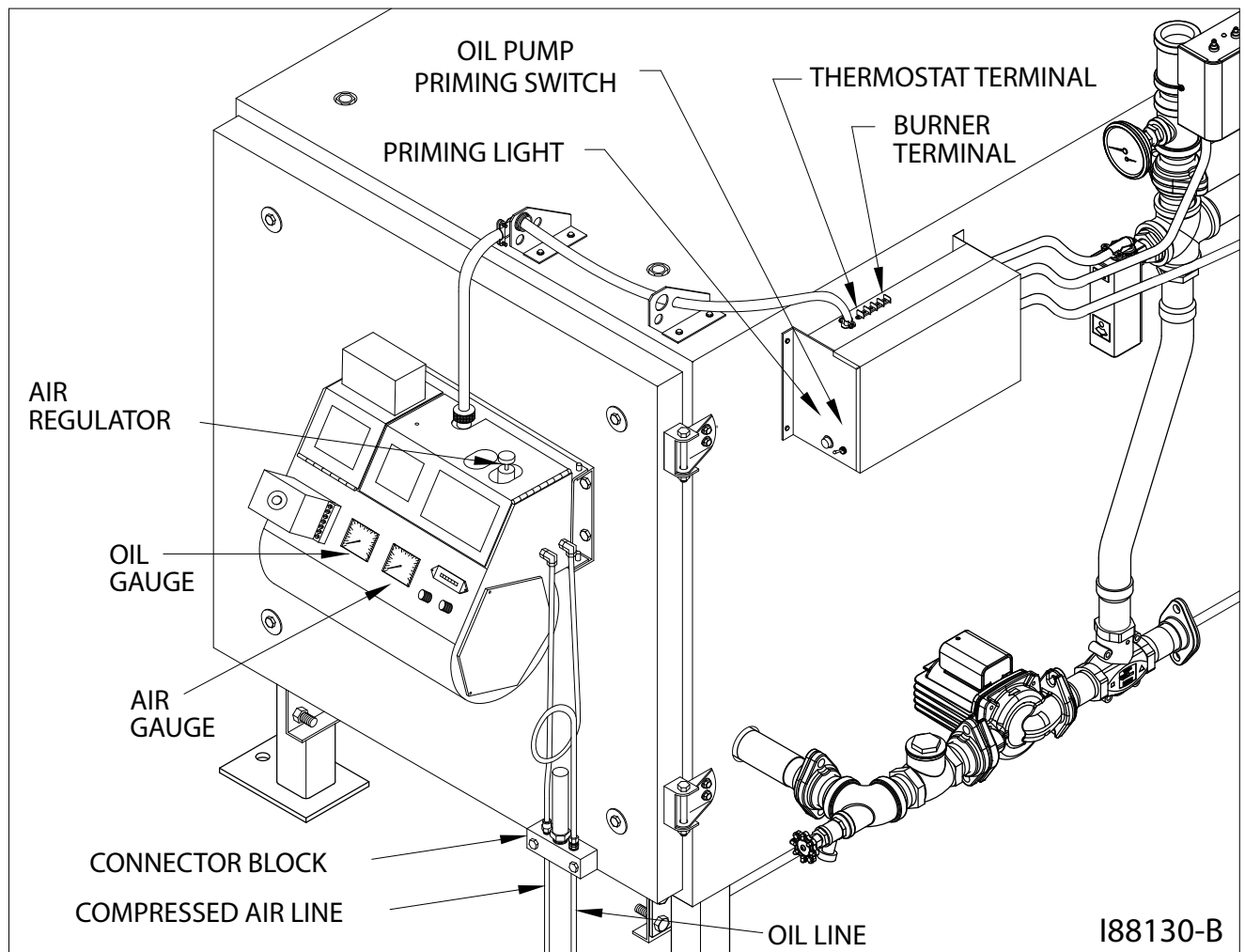

Figure 5B - Detail of Burner Connections/Components

Priming the Metering Pump (continued)

9. Run the pump until a solid stream of oil flows from the pump bleeder. This will bleed all air out of the suction line, oil filter and pump head.
ATTENTION: For the metering pump to operate correctly, it is very important that the system is entirely full of oil and all air is bled out. The burner will shut down if there is any air in the system.
 10. Open the mini ball valve at the outlet port of the pump head to allow the pressure oil line to be filled.
 11. Close and tighten the bleeder on the pump.
 12. Turn the priming switch to the DOWN position so that the pump stops running.
 13. Disconnect the pressure oil line from the burner and position a container to catch oil which will flow from the pressure oil line during pump priming.
 14. Turn the priming switch to the UP position. The pump should start running immediately .
 15. Run the oil pump until the proper flow of oil has been established, and the oil line has been completely flushed out.
 16. Turn the priming switch to the DOWN position so that the pump stops running.
 17. Re-connect the oil line to the connector block.
-

Vacuum Testing the Oil Pump

Vacuum testing the oil pump is a very accurate way to determine the following:

- The condition of the pump -- the ability of the pump to pull a vacuum and suck oil from the tank.
- The condition of the fittings, gaskets and seals from the ball valve to the pump -- these components must all be airtight to avoid suction leaks.

The following procedure provides instructions for vacuum testing the pump and canister filter on systems equipped with a ball valve.

ATTENTION: For the pump to pull and hold vacuum, it is critical that all fittings are airtight. If any of these fittings are loose, the pump may not pull a vacuum or may lose the vacuum rapidly. It is also critical that all fittings in the suction line, including fittings on the canister filter, are 100% airtight.

1. Follow the instructions to prime the pump (previous procedure).
NOTE: The pump will not pull a vacuum if the pump is dry. There must be oil in the gears of the pump before the pump can pull a vacuum.
2. With the pump running, open the bleeder two to three full turns, and make sure that oil is flowing from the bleeder. **DO NOT** close the bleeder yet.
3. Refer to Figure 5A. Close the ball valve at the inlet to the canister filter. Observe the vacuum gauge.
NOTE: The ball valve must have a stainless steel ball and should be pressure tested by the manufacturer to ensure that it does not leak. If the ball valve leaks, the vacuum test will not be accurate.
4. The vacuum should increase within 30 seconds to 15 inches of vacuum. When the vacuum gauge reads 15 inches of vacuum, first close and tighten the bleeder, then turn the pump off and close the mini ball valve at the outlet port of the pump. Observe the vacuum gauge.
NOTE: If the pump will not pull at least 15 inches of vacuum, there is a very serious suction leak, or the pump is damaged.

Vacuum Testing the Oil Pump (continued)

5. If there are no suction leaks, the system will hold vacuum.
NOTE: It is acceptable for the vacuum to drop one to five inches within one minute as the seal in the pump seats. The vacuum should then hold steady for 15 minutes.

ATTENTION: If the vacuum drops *more than one to five inches within the first minute*, there is one or more leaks somewhere between the pump and the ball valve. Do the following:

- Wipe your finger along the cylinder at the shaft of the pump. If there is oil here, the pump seal is damaged. Replace the pump.
 - Disassemble and clean all the fittings from the pump to the ball valve. Properly seal all fittings with Permatex #2 non-hardening gasket sealer or equivalent. Check the condition of the o-ring on the canister filter and tighten the four canister filter bolts in a crisscross pattern.
 - Repeat the procedure to vacuum test the system to ensure that the system is air tight.
6. Follow the instructions to prime the metering pump after a vacuum test has been performed.

SECTION 6: STARTING AND ADJUSTING THE BURNER

Understanding Burner Startup and Adjustment

ATTENTION: Before starting the burner, you must fill the coil tube boiler with water. Refer to Section 10 in this manual for more information on the hydronics system. *DO NOT bypass the CTB controls to operate the burner!*

FOR DUAL-STACKED UNITS ONLY: Clean Burn recommends that you complete burner startup and adjustment for one burner before starting the second burner.

Starting and adjusting the burner involves a series of separate procedures which must be accomplished in sequence without interruption. Review all the procedures before attempting burner startup and adjustment, paying careful attention to safety information statements.

Preparing the Hydronics System for Burner Startup

The following procedure should be performed prior to burner startup to ensure that all key components of the hydronics system are functioning properly. Ensure that air is purged from the system. If the CTB circulator becomes air-bound, it will not produce sufficient flow to activate the flow switch, and the burner will not start properly.

1. Turn the load temperature controller (i.e. thermostat or aquastat) OFF.
2. Set the operating aquastat (on the CTB) at 180 to 200 °F.

Preparing the Burner for Startup

1. If you have not already done so, disconnect one wire from the terminal block at the "thermostat" connection. (This prevents the burner from running.) A wiring diagram is provided in Appendix B.
2. Turn the main power to the CTB ON (the green power light on the burner should be ON).
3. Wait at least 15 minutes until the preheater block is thoroughly warmed up. (Feel the back of the burner box to make sure the preheater is sufficiently warm. The proving switch on the preheater block will not allow the burner to start until the block is at least 120 °F.)
NOTE: The preheater block will remain warm as long as power is supplied to the burner. If the main power supply is ever turned OFF, you must wait at least 15 minutes until the preheater block is thoroughly warm before starting the burner.

(Continued)

**Preparing the Burner for Startup
(continued)**

4. Refer to Figure 6A. Loosen the locking nut on the air regulator.
5. Turn the adjustment knob on the air regulator counterclockwise until 1/2" of the threads on the knob are exposed. **DO NOT** back the knob all the way out. **NOTE:** The air gauge will not show any pressure until the burner starts. Before starting the burner for the first time, it is very important to turn the air regulator completely OFF as described.
6. **Initial Adjustment of the Combustion Air Band**
 Rotate the combustion air band to adjust it to the appropriate slot opening as listed in the following **Initial Adjustment Chart**. Use a ruler to accurately set the slot opening at the widest section of the slot.

WARNING: The combustion air

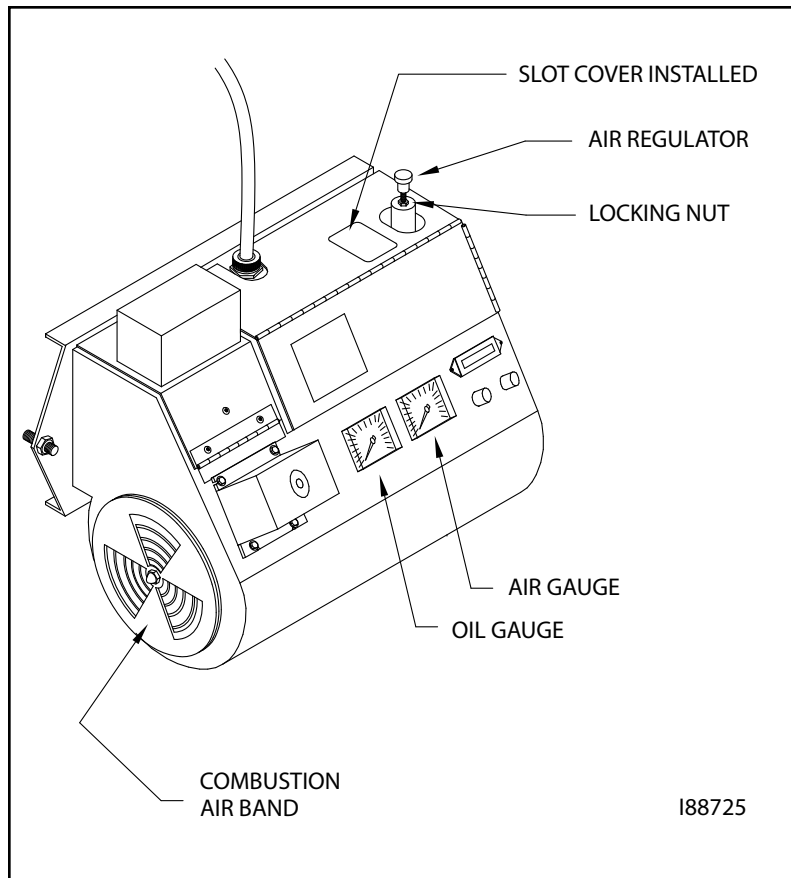

**Figure 6A - Component Detail of the CB-551-H3 Burner
(CB-525-S2 Burner is similar)**

! must be properly adjusted to ensure that the burner ignites and burns correctly. **DO NOT** attempt to start the burner with the combustion air band wide open or completely closed. The burner may not ignite correctly. Failure to heed this warning may result in a fire or explosion hazard.

IMPORTANT NOTE: This initial setting of the combustion air band will allow you to start the burner. You will fine tune the combustion air band further as described later in these instructions.

ATTENTION: The settings shown in the chart below are only *initial* adjustments. **Final adjustments must be done by inspecting the flame length according to the illustrations provided on the following page.**

NOTE: The oil pressure is automatically adjusted by the metering pump.

Initial Adjustments for CB-200-CTB

NOTE: Only Gearmotor part #33507 may be used with the CB-200-CTB.

Maximum Input = 200,000 BTUH @ 1.4 GPH per CB 525-S2 Burner

Oil Type	Oil PSI / Flame Length	Air PSI	Air Band	Nozzle
#2 Fuel Oil*	<i>check flame length</i>	14	3/8" - 1/2"	9-5
Used Crankcase Oil	<i>check flame length</i>	14	3/8" - 1/2"	9-5
Used ATF	<i>check flame length</i>	18	3/8" - 1/2"	9-5
Used Hydraulic Oil	<i>check flame length</i>	14	3/8" - 1/2"	9-5
#4 and #5 Fuel Oils	<i>check flame length</i>	18	3/8" - 1/2"	9-5

Preparing the Burner for Startup (continued)

Initial Adjustments for CB-350-CTB

NOTE: Only Gearmotor part #33295 may be used with the CB-350-CTB.

Maximum Input = 350,000 BTUH @ 2.5 GPH per CB 551-H3 Burner

Oil Type	Oil PSI / Flame Length	Air PSI	Air Band	Nozzle
#2 Fuel Oil*	<i>check flame length</i>	12-16	1/2"	9-5
Used Crankcase Oil	<i>check flame length</i>	12-16	1/2"	9-5
Used ATF	<i>check flame length</i>	12-16	1/2"	9-5
Used Hydraulic Oil	<i>check flame length</i>	12-16	1/2"	9-5
#4 and #5 Fuel Oils	<i>check flame length</i>	12-16	1/2"	9-5

Initial Adjustments for CB-500-CTB

NOTE: Only Gearmotor part #33558 may be used with the CB-500-CTB.

Maximum Input = 500,000 BTUH @ 3.57 GPH per CB 551-H5 Burner

Oil Type	Oil PSI / Flame Length	Air PSI	Air Band	Nozzle
#2 Fuel Oil*	<i>check flame length</i>	18	1/2"	9-28
Used Crankcase Oil	<i>check flame length</i>	18	1/2"	9-28
Used ATF	<i>check flame length</i>	22	1/2"	9-28
Used Hydraulic Oil	<i>check flame length</i>	24	1/2"	9-28
#4 and #5 Fuel Oils	<i>check flame length</i>	18	1/2"	9-28

* If you are burning light viscosity oils such as #2 fuel oil, it may be necessary to install a smaller nozzle. Call your Clean Burn dealer for more information.

Starting the Burner

- Re-connect the control wire. Turn the aquastat to call for heat (to start the burner).
NOTE: The CB-350-CTB and CB-500-CTB burner oil primary controls include alarm contacts which will close should the burner fail to start. **If the burner refuses to start**, review the *Preparing the Burner for Startup* procedure. If, after repeating this procedure, the burner still refuses to start, check the following system components for proper functioning:
 - Verify that the red wire (per the burner wiring diagram) is energized to 115VAC.
 - Reset the hi-limit switch.
 - If the flow switch is not closing, the circulator is air-locked. Air must be purged from the system.
 - Verify that the prime switch (on the control box) is set to RUN (DOWN position).
- Adjusting the Air Regulator:**
As soon as the burner starts running, turn the knob on the air regulator clockwise to achieve proper operating air pressure. Refer to the **Initial Adjustment Charts**.
NOTE: If the safety reset on the primary control is activated and the burner stops running, see Section 7 for further instructions on restarting you burner.
- Observing the Flame Length:**
Visually inspect the flame length through the observation port. Refer to Figure 6B for an illustration of the desired flame length. The flame should extend no more than one-half of the way down the chamber.
 **WARNING:** The observation port gets hot as the burner fires. To avoid personal injury, always wear heavy work gloves and safety glasses when opening the port and viewing the flame.

CAUTION
WHEN OPENING INSPECTION PORT

**PORT MAY BE HOT
PROTECT HANDS
WEAR SAFETY GOGGLES
KEEP FACE AWAY
OPEN PORT SLOWLY**

Starting the Burner (continued)

<p>Correct Maximum Flame Adjustment (Proper Oil and Air Pressure)</p> <ul style="list-style-type: none">• Flame goes half of the way down the combustion chamber.• Flame does not touch back of walls of combustion chamber.	
<p>Incorrect Flame Adjustment (Not Enough Combustion Air)</p> <ul style="list-style-type: none">• Flame must not touch back or walls of combustion chamber.• Increase combustion air by opening the air band on the side of the burner.	
<p>Incorrect Flame Adjustment (Air Pressure too high)</p> <ul style="list-style-type: none">• Ensure proper air pressure setting	 <p style="text-align: right;">188372</p>

Figure 6B - Flame Length Adjustment

4. Check the flame length after the burner has fired for 15 minutes.
5. Tighten the locking nuts on the air regulator.

Starting the Burner (continued)

6. **Checking for Proper CTB System Operation:**

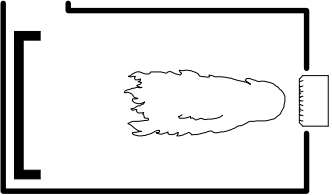
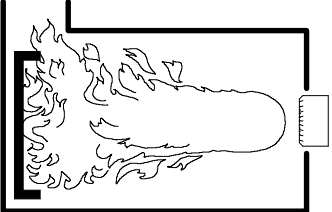
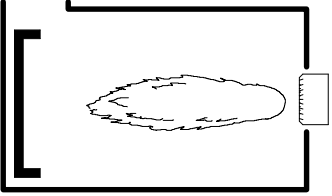
Observe the boiler temperature and water pressure.

7. After the burner stops running when the operating aquastat set temperature is reached, check the following:

- air has been purged from water lines
- water pressure is satisfactory (i.e. not greater than 22 psi; normal pressure is 12 psi)
- all system controls functioning properly

8. Reset the operating aquastat to the normal operating range (180-200 °F) and repeat steps 6 and 7, observing the CTB operation.

9. Reset the load temperature controller (i.e. thermostat or aquastat) to the normal operating temperature.

10. As the CTB temperature drops, the burner will start running. Continue observing the CTB operation through several burner ON/OFF cycles to ensure proper system performance.

11. **Fine Tuning the Combustion Air Band:**

NOTE: The initial setting of the combustion air band may require additional adjustment.

- Refer to Figure 6A to identify the combustion air band location on the burner.
- Observe the flame. The flame should be yellow-white with sharp tips and no "sparkles."
- If the flame is orange in color or the flame length is too long, the oil you are burning requires MORE combustion air. OPEN the air band 1/8" to 1/4", and re-check the flame for the proper characteristics.
- Re-check the flame after five minutes. You should see a yellow-white flame with sharp tips and no "sparkles", and the flame should extend half of the way down the combustion chamber.

12. **Checking for a Smokeless Burn:**

Check for a smokeless burn by observing the stack while the burner is running. If you see any smoke, repeat the previous steps for setting the combustion air band and adjusting the air regulator. After adjusting the combustion air band, re-check the flame length.

NOTE: Check for a smokeless burn periodically (as you do the flame length). Immediately readjust the burner if you ever see smoke coming from the stack. Smoke indicates improper air/fuel adjustment.

NOTE: When using instruments to adjust the burner for a smokeless burn, the following readings should be achieved:

- Draft over fire should be -.02 inch w.c. to -.04 inch w.c.
- Adjust for a smoke spot of a trace to 1
- For the CB-500-CTB adjust for a CO₂ reading of 12.5 to 14% or an O₂ reading of 2 to 4%
- For the CB-350-CTB adjust for a CO₂ reading of 12 to 13.5% or an O₂ reading of 4 to 7%
- For the CB-200-CTB adjust for a CO₂ reading of 10.5 to 12.5% or an O₂ reading of 3 to 5%
- Cad cell reading of 200 to 500 ohms

NOTE: On the CB-200-CTB, the flame cannot be observed through the inspection door. **The CB-200-CTB must be adjusted with instruments for proper combustion.** Obtain the above settings by adjusting the air band 3/8" to 1/2". The metering pump will deliver a constant oil flow and set the flame length accordingly.

SECTION 7: RESETTING THE OIL PRIMARY CONTROL

Understanding the Oil Primary Control (CB-200-CTB)

(See Appendix B for additional information)

The oil primary control will go into safety lockout and shut the burner off when it detects flame-out during burner operation. The following procedure explains what should be done when this occurs.

It is very important that you follow these instructions precisely when resetting the safety on the primary control and restarting the burner.

Resetting the Oil Primary Control (CB-525-S2 Burner)



DANGER! DO NOT push the reset button more than once! DO NOT push the reset button if oil mist is present in the combustion chamber or when the combustion chamber is hot! DO NOT operate your boiler if excess oil, oil vapor or fumes have accumulated in or near your boiler. As with any oil burning appliance, improper operation may result in a fire or explosion hazard.

1. Refer to Figure 7A.
2. Check the combustion chamber for fuel mist by shining a flashlight through the observation port. If you see fog (fuel mist) in the chamber, DO NOT push the reset button.
3. If the combustion chamber is hot, allow the furnace to cool for at least 30 minutes. DO NOT push the reset button.
4. When you are sure all mist has been cleared from the chamber and the combustion chamber is cool, depress the red button on the primary control for 2 seconds, then release. Reset the control **ONCE ONLY**.
5. If the burner will not restart, call your Clean Burn dealer immediately.

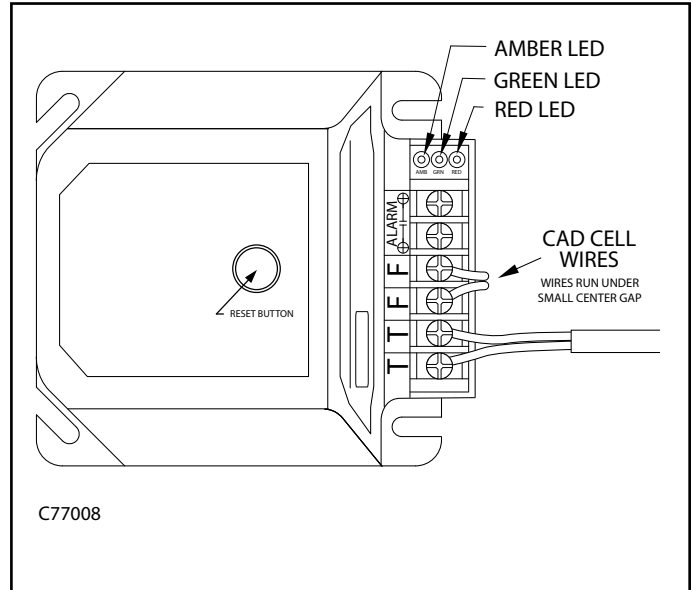

Figure 7A - Oil Primary Control for CB-200-CTB



ATTENTION: It is very important that the "F" and "T" terminals of the Oil Primary Control are wired exactly as shown in Figure 7A.

NEVER connect jumper wires to these terminals or severe damage may occur to the Oil Primary Control.

Understanding the Oil Primary Control (CB-350-CTB and CB-500-CTB)

(See Appendix B for additional information)

NOTE: *This is a new control featuring the ability to activate a remote alarm in case of lock-out or latch-up.*

The oil primary control will go into safety lock-out and shut the burner off when it detects flame-out during burner operation. The oil primary control will then wait approximately one minute and attempt to re-ignite the burner (recycle mode). If the burner does not re-ignite, the control will shut the burner off on safety. The following procedure explains what should be done when this occurs. *It is very important that you follow these instructions precisely when resetting the safety on the primary control and restarting the burner.*

Resetting the Oil Primary Control (CB-551-H3 and CB-551-H5 Burners)

⚠ DANGER! DO NOT reset the oil primary control if oil mist is present in the combustion chamber or when the combustion chamber is hot! DO NOT operate your CTB if excess oil, oil vapor or fumes have accumulated in or near your boiler. As with any oil burning unit, improper operation may result in a fire or explosion hazard.

1. Refer to Figure 7B.
2. Check the combustion chamber for fuel mist by shining a flashlight through the observation port. If you see fog (fuel mist) in the chamber, DO NOT push the reset button.
3. If the combustion chamber is hot, allow the boiler to cool for at least 30 minutes. DO NOT push the reset button.
4. When you are sure that all fuel mist has cleared and the boiler has cooled, push in and hold the reset button for one second, then release. This will reset the control at any time during its operation.

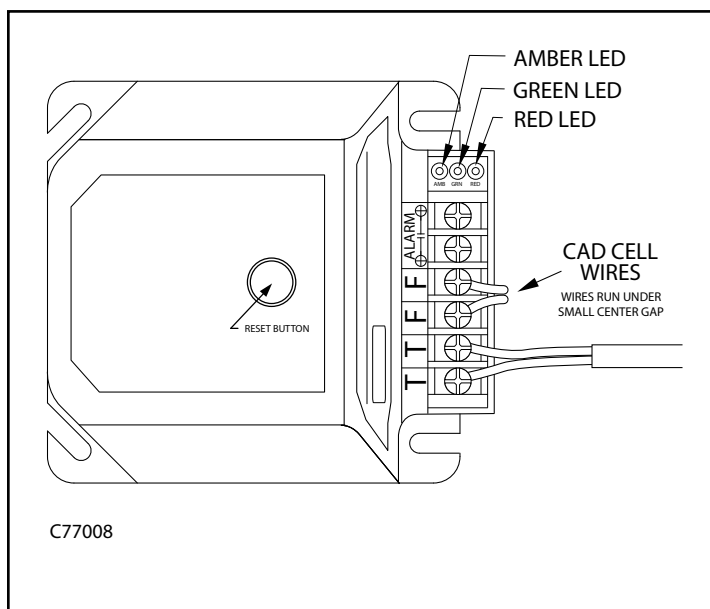

**Figure 7B - Oil Primary Control For
CB-350-CTB and CB-500-CTB**



ATTENTION: It is very important that the "F" and "T" terminals of the Oil Primary Control are wired exactly as shown in Figure 7B. NEVER connect jumper wires to these terminals or severe damage may occur to the Oil Primary Control.

Resetting the Oil Primary Control (continued)

5. Set the load temperature controller to call for heat.
NOTE: Main power should be ON and all hand-operated oil line valves open. When the call for heat is detected, the oil primary control will perform a 5 second self-test which is indicated by a "solid on" amber LED. After the self-test, the amber LED will turn OFF, and the burner will start.
6. If flame is not established within 15 seconds (TFI-Try For Ignition), **lock-out** will occur. **Lock-out is indicated by a "solid on" red LED and closure of the alarm contacts (see NOTE below).** To reset the control, repeat step 4.
7. **Latch-up** occurs if the control locks-out and is reset three times during a call for heat. **Latch-up is indicated by "solid on" red and amber LEDs.**
8. To reset the control from a latch-up condition:
WARNING: Only a qualified service technician should attempt to reset the control after latch-up. The problem that caused the repeated burner lockouts must be corrected before returning the burner to normal operation.
 - Push in and hold the reset button for 10 seconds. The amber LED will begin to flash.
 - After the LED begins flashing, continue holding the reset button for 20 seconds. The LEDs will turn off. Release the reset button and the control will restart (releasing the button before the LEDs turn off will cause the control to remain in latch-up)
NOTICE: The 50200 control will not reset from lockout or latch-up if power is interrupted.
9. When the load temperature controller opens, the burner motor turns off within 1.2 seconds.
10. If flame is lost during a normal run (after TFI), the burner motor turns off after 1.2 seconds. A 65-second recycle period begins, indicated by a blinking red LED. The control will restart automatically after the recycle period.
11. Power loss during a normal run will cause the burner to safely shut down and begin a normal TFI when power is restored.
12. If the burner will not restart at all (after having attempted oil primary control reset), contact your Clean Burn dealer immediately.

NOTE: The oil primary control on the CB-551-H3 and CB-551-H5 Burners provides an extra set of dry contacts to accommodate an externally-mounted horn, siren, bell, or other alarm device. The contacts close when the control goes into either lock-out or latch-up mode. Because these are dry contacts, power must be supplied from an external source. The contacts are rated for 24 VAC or DC at 2 amps.

SECTION 8: ADJUSTING THE DRAFT OVER FIRE

Understanding the Importance of Draft

Draft in the Coil Tube Boiler is created as the hot combustion gases rise up the stack, creating a negative pressure inside the stack and the boiler. This negative pressure is measured as inches of water column (W.C.) of draft. A proper draft overfire of -0.02 w.c. is essential so that all combustion products travel away from the burner, down the combustion chamber, through the boiler flues and up the stack.

Checking for Correct Draft Over Fire

NOTE: The CTB's are equipped with an observation/draft reading port to check draft over fire. *A qualified serviceman with proper equipment must adjust your CTB for proper draft.* Contact your Clean Burn dealer for this service.

1. Insert the probe of the draft gauge instrument into the draft reading port in the observation port as shown in Figure 8A.
2. Adjust the barometric damper to achieve the *required draft over fire of -0.02 w.c.* (water column).
3. Record the reading in the Maintenance Record located in the Appendixes.
4. If correct draft over fire cannot be achieved, contact your Clean Burn dealer immediately.

ATTENTION: Only operate your CTB with a draft over fire of -0.02 w.c. Poor draft results in back pressure and poor burner performance. **DO NOT** operate your CTB with a draft over fire greater than -0.04 w.c.; an abnormally high stack temperature may result from a draft over fire that is too high.

ATTENTION: Backdraft must be resolved or your boiler will not operate correctly!

Under backdraft conditions, draft overfire readings will show positive pressure in the combustion chamber. Backdraft means that oil spray, combustion products, and heat are blown back against the burner. Backdraft results in oil-fouled retention heads and electrodes.

Severe backdraft will force heat back against the burner and result in heat damage to the cad cell and transformer.

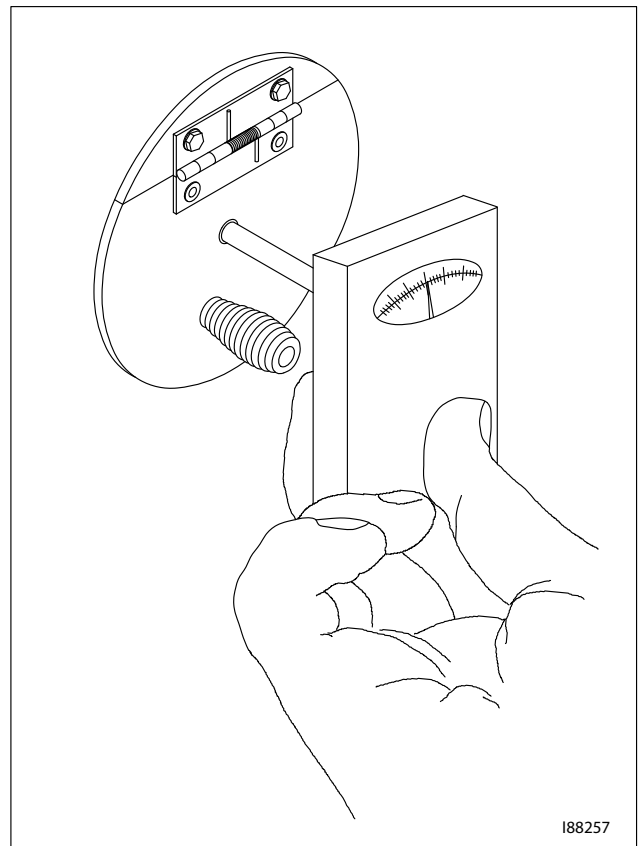

Figure 8A - Checking for Proper Draft Over Fire

Checking for Correct Draft Over Fire (continued)

Backdraft is caused by the following conditions:

- Poor draft caused by improper stack design. (See Section 4.)
- Poor draft caused by improper adjustment of the barometric damper.
- Incorrect combustion air band setting on the burner. (See Section 6.)
- Boiler flues are plugged with ash. (See Section 9.)
- Improper seal on clean-out door on back panel. (See Section 9.)
- Exhaust fans in your building are sucking gases down the stack.

Understanding the Effect of Exhaust Fans on Draft

Any type of exhaust fan, paint booth, or exhaust system in a building will create negative pressure in the building unless there is a source of make-up air (i.e. fresh air which enters the building and replaces the air removed by the exhaust fans.)

If there is insufficient make-up air, the exhaust fan will suck air and combustion gases down the coil tube boiler stack and create backdraft in the boiler. After the burner is shut down, the backdraft may suck the residual heat out of the combustion chamber and into the burner causing damage to the burner. Even if the exhaust fan is on another level of the building or in another room away from the boiler, the exhaust fan will still create backdraft at the boiler.

Checking Draft Overfire to Determine Severity of Backdraft

The following procedure is an accurate method of determining how much backdraft is created by the exhaust fans. Once this is determined, you can select the correct method for resolving the backdraft.

1. Turn off ALL exhaust fans and close ALL doors and windows in the building (any open door or window will allow make-up air to enter the building and will negate the test).
2. Start the coil tube boiler and adjust the barometric damper so that the draft overfire is $-.02$ w.c.
3. Check the draft overfire again. Now have someone start the exhaust fans.
4. Note how much the draft overfire has changed.

ATTENTION: If the draft overfire changed towards positive, it is mandatory that make-up air is provided to the building or severe damage to the boiler and burner will occur (voiding the warranty). If the draft overfire remained constant at $-.02$ w.c., there is sufficient make-up air entering the building, and the exhaust fan is not adversely affecting the draft.



CAUTION: Under no circumstances should the equipment room ever be under a negative pressure. Look for exhaust fans, compressors, air handling units, or anything else that may take air away from the boiler. Also look for chemical fumes, solvents, refrigerants, etc. that may be in use around the boiler and cause damage to it.

Adjusting Draft Over Fire with A Draft Inducer Installed

NOTE: The draft inducer is purposely sized to create a generous draft. When adjusting the barometric damper, you will find that the flapper is open most of the time. This allows the draft inducer to suck cool air through the damper to protect the inducer motor from heat damage.

1. Use a draft gauge to check draft over fire.
2. Adjust the barometric damper to obtain -0.02 w.c. draft over fire. If you still have too much draft, adjust the draft plate on the draft inducer. Move the plate in 1/4" to reduce the draft. Recheck the draft reading.

SECTION 9: MAINTENANCE

Understanding Maintenance

Maintaining your Clean Burn CTB is an important activity which includes several periodic maintenance activities and an annual burner tune-up...all are necessary to keep your boiler running in peak condition.



WARNING: Failure to maintain and/or improper servicing by unqualified personnel may adversely affect the proper, safe operation of your coil tube boiler, may reduce the service life of your boiler, and may void your warranty.

The following chart summarizes all the maintenance activities which should be performed on the CTB at the intervals indicated. Instructions/procedures for these activities are included in this chapter.

Maintenance Activity	Interval
Cleaning the canister filter	Before vacuum gauge reads 10" HG of vacuum
Servicing the metering pump	At least once a year
Cleaning the check valve/screen	At least once a year
Cleaning water/sludge out of oil tank	At least once a year
Cleaning out ash (CB-200-CTB)*	Approx. every 750 hrs. per burner hour meter
Cleaning out ash (CB-350-CTB)*	Approx. every 1000 hrs. per burner hour meter
Cleaning out ash (CB-500-CTB)*	Approx. every 1000 hrs. per burner hour meter
Cleaning / Maintaining the Draft Inducer	At least once a year
Checking boiler water condition	Periodically by qualified water treatment company
Annual burner tune-up	At least once a year

*It is very important to clean the ash from the CTB on schedule. Normal use of the boiler requires clean-out at least twice during the heating season. Heavy, around-the-clock usage requires more frequent clean-out (e.g. one month of continual running of the boiler is 720 hours).

NOTE: IMPORTANT! Record all maintenance activities in the Maintenance Record provided in the Appendixes.

Annual Preventative Maintenance and Burner Tune-up

The Clean Burn CTB requires annual preventative maintenance. The burner also requires an annual tune-up to keep it running in peak condition. The burner tune-up should be performed by a qualified Clean Burn service technician who has the necessary parts and expertise.

Contact your local Clean Burn dealer to schedule the annual maintenance for your boiler. Various levels of service are provided to fit your particular need. This work is usually performed during the warm-weather months to prepare the boiler for the next heating season.

Cleaning the Canister Filter

ATTENTION: Never operate the oil pump with more than 10" HG of vacuum on the vacuum gauge. High vacuum on the suction side of the pump separates air from the oil (cavitation) and will cause the burner to shut down.

The following protective gear should be worn when cleaning the filter:

- Rubber gloves
- Safety goggles

1. Close the ball valve adjacent to the filter.
2. Position a container under the filter.
3. Unscrew the four bolts, remove the canister bowl, and filter element. Now pour the oil into the container.
4. Clean the filter element and the bowl in a parts washer.
5. Referring to Figure 9A, check the condition of the O-rings. Replace any that are cracked or worn.
6. Ensure that the canister filter is 100% airtight by firmly tightening the four bolts.
7. Open the ball valve. Refer to Sections 5 and 6 for instructions on priming the pump and starting the burner.

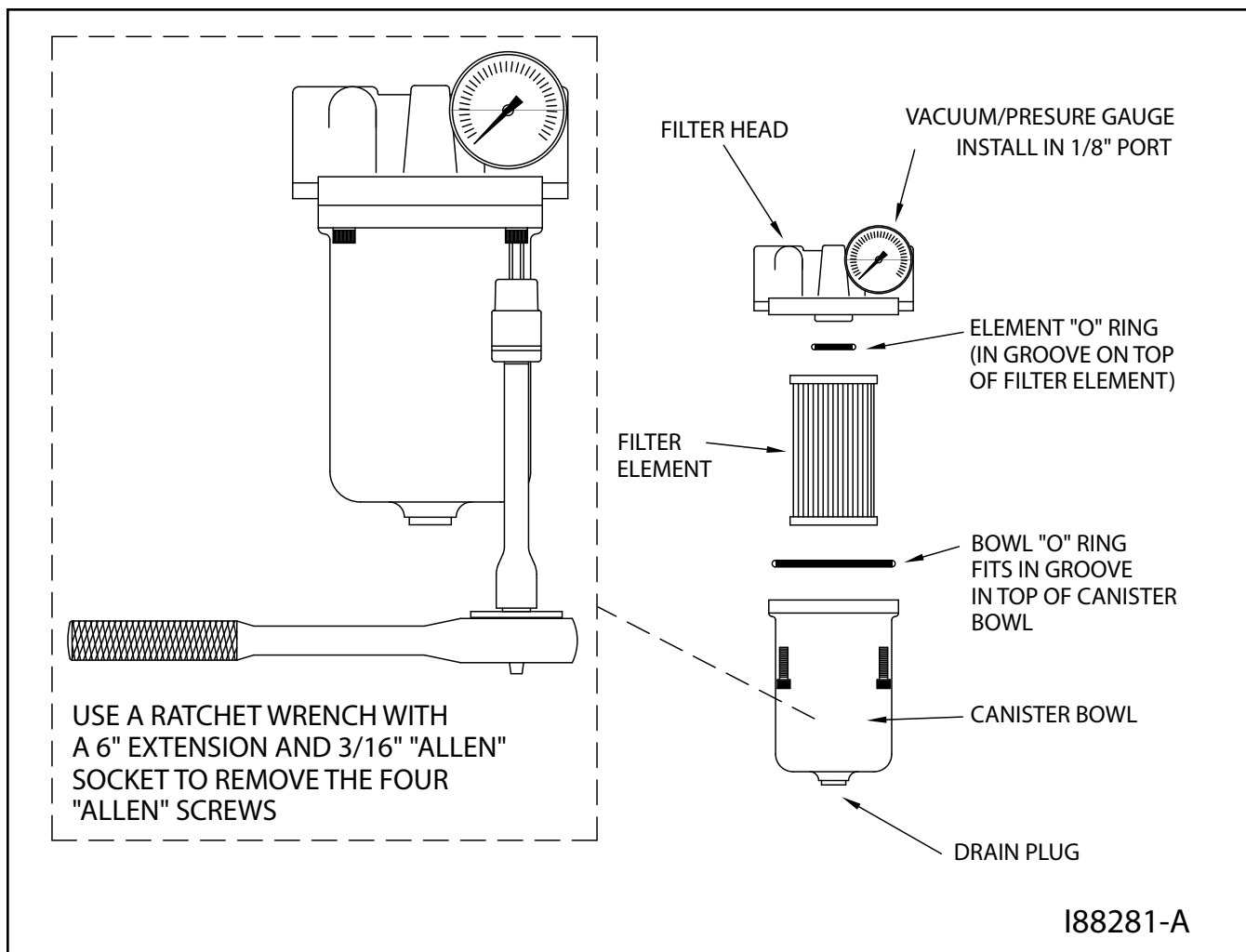

Figure 9A - Canister Filter Component Detail

Servicing the Metering Pump

1. Refer to Figure 9B.
2. Remove the pump head cover (part 1).
3. Remove the screen (part 2) and wash it.
4. Remove and discard the used gasket (part 3).
5. Install a new gasket (Clean Burn Part #32422).
6. Replace the screen and pump head cover.

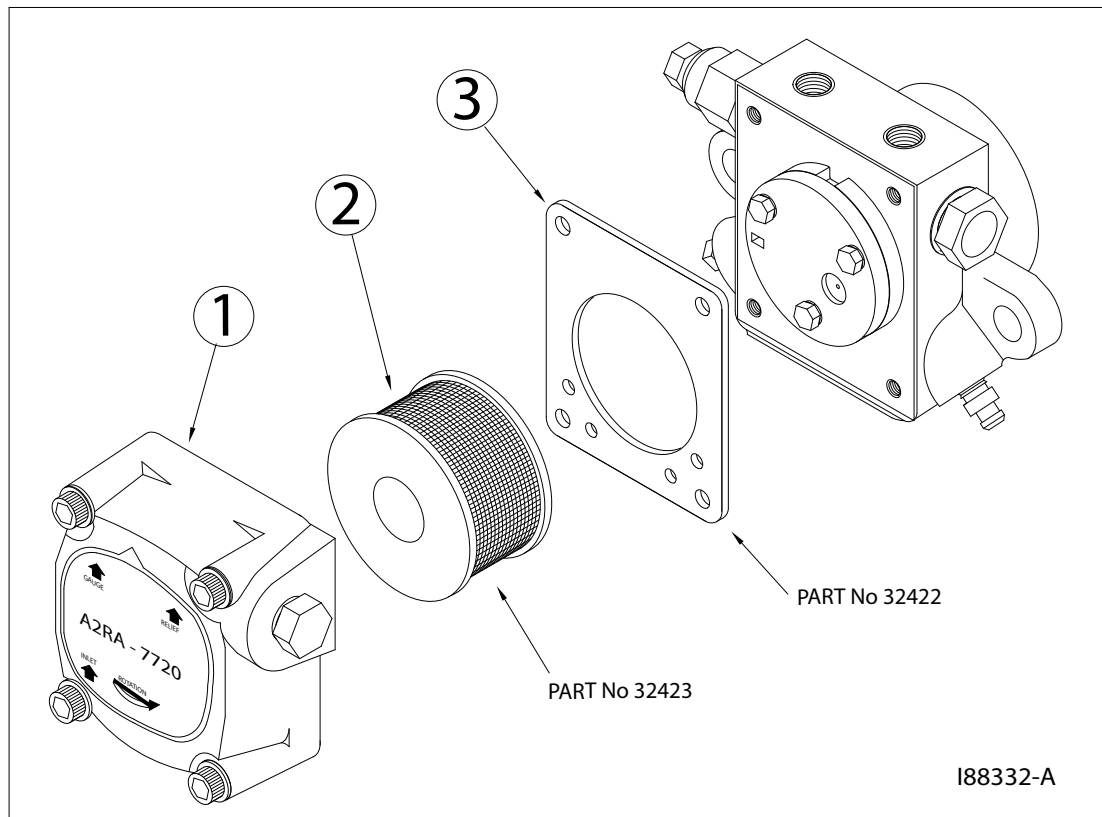

Figure 9B - Servicing the Metering Pump

Cleaning the Check Valve / Screen

This procedure applies to coil tube boiler installations with inside and outside tanks. The following protective gear should be worn when cleaning the check valve/screen:

- Rubber gloves
- Safety goggles

1. Refer to Figure 9C. Remove the one-piece suction oil line from the tank.
2. Remove the check valve and screen. Clean these components in a parts washer.
3. Check the operation of the check valve. The valve must seat so it is airtight to hold pump prime.
4. Re-assemble and re-install the components. Apply Permatex #2 non-hardening gasket sealer or equivalent to the threaded fittings. Firmly tighten all connections so the suction line is 100% airtight.
5. Follow pump priming instructions in Section 5 to re-establish prime.

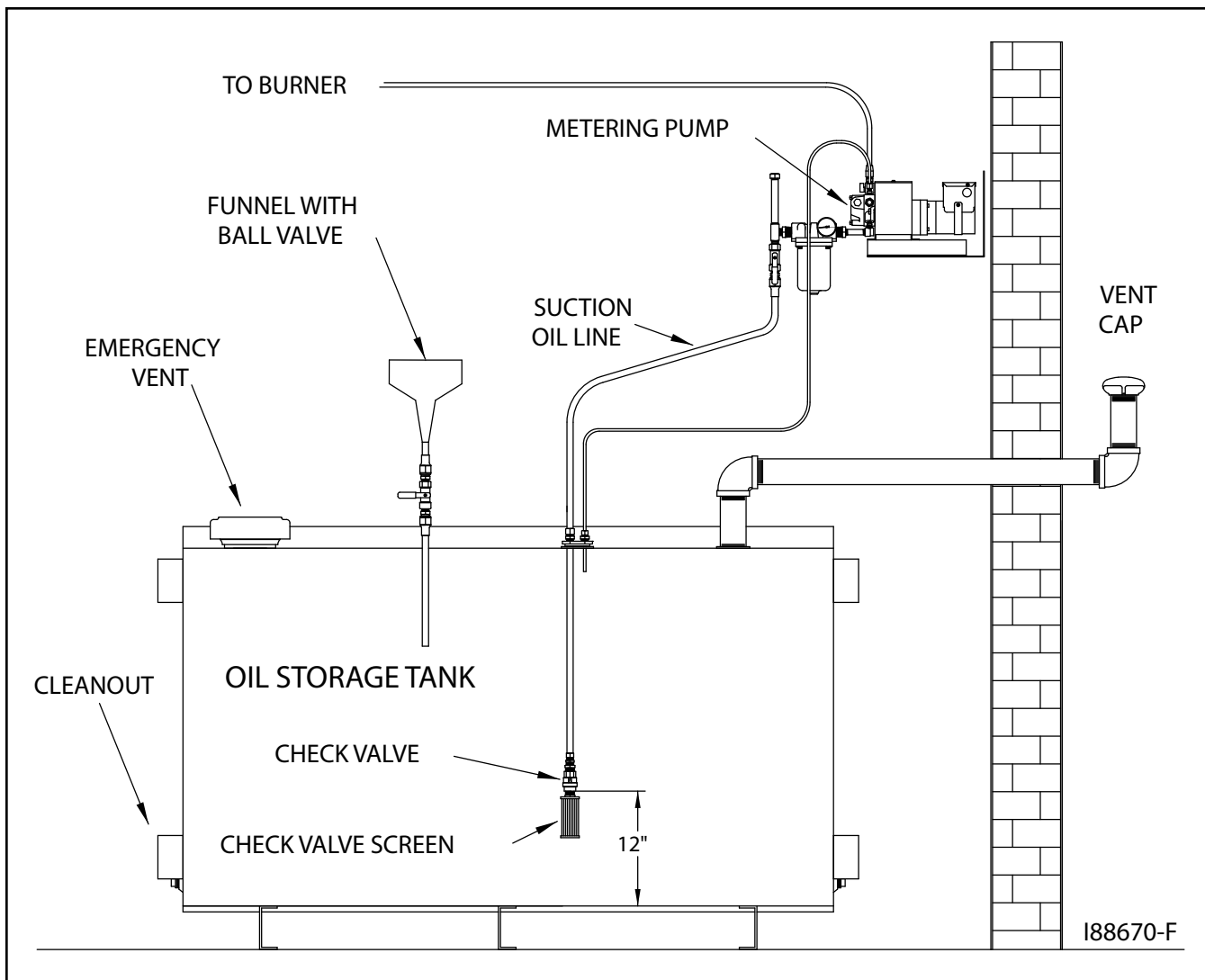

Figure 9C - Check Valve Detail

Cleaning the Ash from the Coil Tube Boiler

ATTENTION: Your CTB may require frequent clean out of the ash due to contaminants in the oil or heavy use. As ash accumulates, CTB heat output declines, and the stack temperature rises. 1/8" of ash has the insulating capacity of one inch of fiberglass insulation and reduces heat transfer significantly. Never allow more than 1/4" of ash to accumulate in the combustion chamber, heat exchanger flues or stack.

The following protective gear should be worn when cleaning the ash:

- Respirator for fine particles
- Rubber gloves
- Safety goggles
- Protective clothing

1. Ensure that power has been turned OFF, and all "hot" components have been allowed to cool sufficiently. Shop air should be turned OFF and disconnected. Allow at least one hour for the ceramics to cool.

2. Clean the ash from the combustion chamber (see Figure 9D):
 - a. If the air and oil lines must be disconnected to open the clean out door:
 1. Bleed-down pressure on the air and oil lines by slightly loosening the fittings at the bottom of the connector block.
 2. With air and oil pressure completely bled off, disconnect the air and oil pressure lines from the bottom of the connector block.

NOTE: Cover these lines to keep dirt from entering the air / oil supply.
 - b. Remove the lock nuts on the clean-out door.
 - c. Carefully swing open the clean-out door to expose the coiled heat exchanger, flue passages, and the combustion chamber.
 - d. Remove the ceramic sleeve from the combustion chamber, and remove the supporting stand.
 - e. Use a wire or bristle brush to thoroughly clean out the ash from the combustion chamber and flue passages.
 - f. While cleaning out the combustion chamber, also check the burner retention head and throat. Carefully clean these elements.
 - g. Thoroughly vacuum any remaining ash residue from the flue passages. A long wand on the hose of your shop vac is helpful in reaching all the way back.
 - h. Inspect the combustion chamber and its components to ensure that it is in good condition. Inspect the inside of the clean-out door and target wall. Make sure the refractory material on the inside of the door is in good condition, and the door seals tightly when closed. If the door does not seal tightly, replace any damaged components.
3. Clean the ash from the stack components:
 - a. Brush accumulated ash from the stack cap.
 - b. Lightly tap the stack components to loosen the ash.
 - c. Allow ash and dust to settle in the clean-out tee or elbow, then vacuum out.
 - d. Disconnect the stack from the CTB breach.
 - e. Thoroughly vacuum out the back of the boiler, including the boiler breach (through the breach). If desired, the back panel can be removed for cleaning.

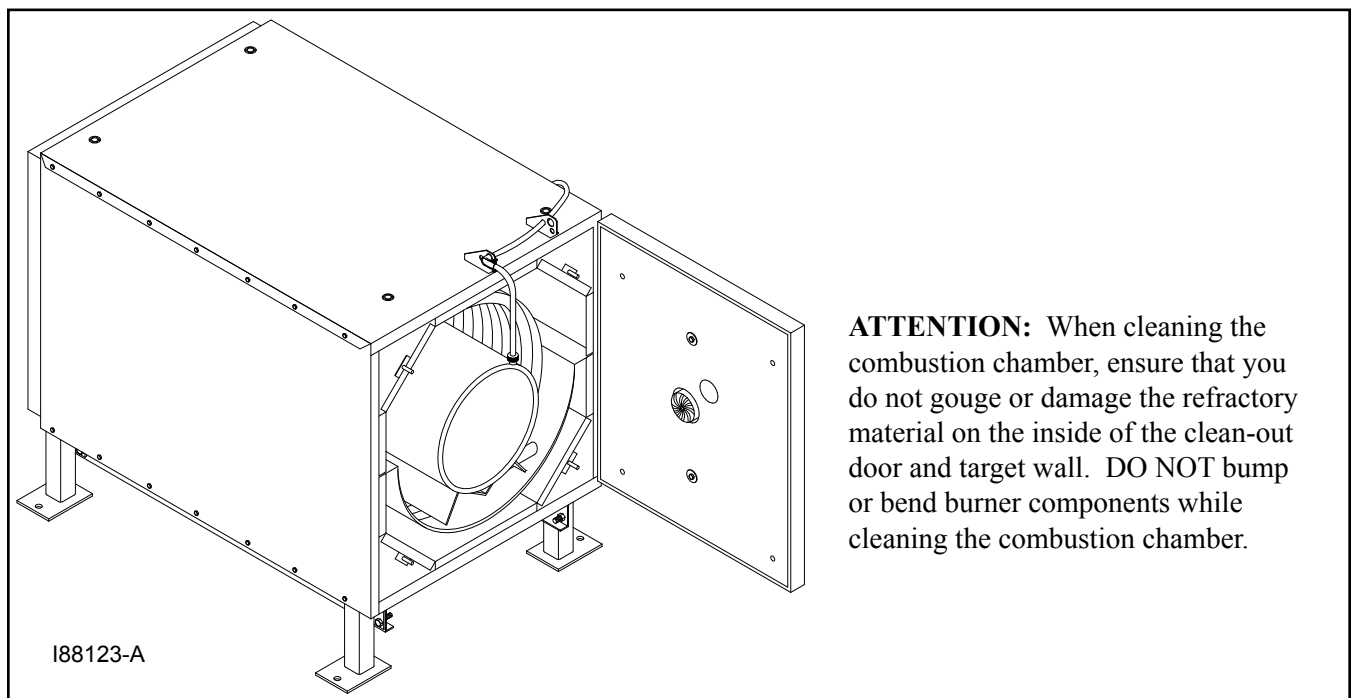

Figure 9D - Accessing the Combustion Chamber for Cleaning

Cleaning the Ash (continued)

ATTENTION: When handling the front door and rear panel, be careful that you do not damage the insulation seal surfaces. Two technicians may be required to remove and install the rear panel safely. The panel weighs approximately 85 lbs.

4. Reassemble the boiler components (ceramic stand, ceramic sleeve, back panel, etc.) If necessary, refer to Section 3 for additional Assembly information.
5. Close the clean-out door, install and tighten the washer and nuts. Make sure that the clean-out door and rear panel close and seal properly. Reconnect all disconnected lines (oil and air) on the bottom of the connector block.

NOTE: You may need to bleed air from the oil line before starting the burner. See Section 5 for pertinent instructions.

Cleaning the Oil Tank

DO NOT allow water, sludge, or other debris to accumulate in your oil supply tank to the point that non-combustible or harmful materials are drawn into the pump or burner.

Drain water and sludge from the bottom of your tank at least once a year, and more frequently with water accumulation.

End of Season Maintenance

Turn main power to your coil tube boiler OFF at the end of the heating season. EPA regulations allow your used oil to be burned only for "heat recovery." DO NOT operate your boiler during warm weather just to burn oil.

Contact your local Clean Burn dealer to schedule your annual burner tune-up. Allow only trained, authorized service personnel to service your burner.

In the "off" season after the boiler has been cleaned, spray the combustion chamber with a light coat of oil to reduce corrosion caused by moisture in the air.

NOTE: If the CTB is not used during the cold-weather months, it must be protected to prevent damage from freezing temperatures.

Cleaning and Maintaining the Draft Inducer

The Draft Inducer will require periodic maintenance to ensure that the fan blades do not accumulate excessive ash which can create vibration, noise, and motor wear.

1. Ensure that power has been turned OFF, and all "hot" components have been allowed to cool sufficiently.
 2. Disconnect the wires from the draft inducer and remove it from the stack penetration.
 3. Clean the fan blades with a scraper and wire brush.
 4. Oil the draft inducer motor according to the manufacturer's recommendations.
-

SECTION 10: THE CTB HYDRONIC SYSTEM

Understanding the CTB Hydronic System

The Clean Burn Coil Tube Boiler (CTB) is designed to function as a low-mass boiler (i.e. it will not maintain boiler water temperature when there is no call for heat). ***Low-mass boilers require that a sufficient, constant flow of water be maintained through the coil*** in order to: (a) remove the heat from the boiler when the burner is firing AND (b) prevent the flow switch from shutting off the burner.

IMPORTANT NOTE: When designing the system layout and application for your CTB, keep in mind that it is NOT suitable for open systems. The Clean Burn CTB has been designed to operate as an ASME Section IV Boiler (i.e. closed loop boiler system). Potable water heating (i.e. for domestic or washing purposes) can be accomplished by incorporating a heat exchanger into the system.

Special Safety Guidelines for the Design and Installation of Hydronic Systems

Adhere to the following ***Safety Guidelines*** when designing and setting up the CTB hydronics system:

- The CTB must be installed on non-combustible flooring.
- The CTB must be installed in accordance with national, state, and local plumbing, heating, and electrical codes and the regulations of the serving utilities which may differ from this manual. Authorities having jurisdiction should be consulted before installations are made. In all cases, reference should be made to the following standards:

- (1) Current Edition of American National Standard ANSI/NFPA 31, "Installation of Oil Burning Equipment" for clearances between boiler, vent connector and combustible material.
- (2) Current Edition of American National Standard ANSI/NFPA 211, "Chimneys, Fireplaces, Vents, and Solid Fuel Burning Appliances" for chimney requirements, type of venting material and clearances between vent connector pipe and combustible materials.
- (3) Current Edition of American Society of Mechanical Engineers ASME CSD-1, "Controls and Safety Devices for Automatically Fired Boilers" for assembly and operation of controls and safety devices.

- The heating system must be designed by a competent hydronics contractor, and only persons knowledgeable in the layout and installation of hydronic heating systems should install this boiler.
- The boiler must be connected to an approved chimney in good condition. Serious property damage could result if the boiler is connected to a dirty or inadequate chimney. The interior of the chimney flue must be inspected periodically through the heating season for any obstructions. A clean and unobstructed chimney flue is necessary to allow noxious fumes that could cause serious injury to vent safely and will contribute toward maintaining the boiler's efficiency.
- It is the responsibility of the installing contractor to see that all controls are correctly installed and are operating properly when the installation is completed.
- To ensure optimum performance, qualified personnel must perform proper and timely maintenance on the CTB according to the procedures provided in Section 9 of this manual.

CTB System Function and Configuration

Water Flow and Temperature

The Clean Burn Coil Tube Boiler design requires continuous water flow through the boiler heat exchanger to ensure proper system operation. The boiler circulator must be capable of developing sufficient (head) pressure to overcome the resistance of the boiler plus the circulating system at the required GPM. If the water flow through the boiler is too low, the flow switch will not allow the burner to operate. (Refer to Appendix A, as needed, for CTB system specifications.)

Heating systems using zone valves, zone pumps, or three-way valves may experience reduced water flow through the boiler. This condition can cause excessive water temperature rise and unstable boiler operation. The normal temperature rise across the boiler is 20 °F. **Minimum operating temperature for the CTB is 180 °F.** To avoid condensation, the return water temperature should not fall below 140 °F.

Boiler Mixing Valve 140 °F

Provided with the boiler plumbing is a 140 °F Mixing Valve set up to blend cold water return from the system to maintain a proper temperature (above 140 °F) for the “Non-condensing” design of the CTB. For optimal boiler operation with the Mixing Valve, and when burning used oils, it is recommended to run the boiler “hot” (180 °F to 200 °F). Therefore **the operating aquastat setting should be no less than 180 °F. The high limit aquastat factory recommended setting is 220-240 °F.**

The 140 °F Mixing Valve must be installed according to Figure 10B or 10C and must be **as close as possible to the suction side of the boiler circulator**. This allows the by-pass loop to function properly. When starting the boiler from cold (room temperature) the boiler water temperature will be able to come up above 140 °F within 5 to 7 minutes (variance caused by unit settings and type of fuel). As the boiler temperature rises above 160 °F the Mixing Valve will modulate and allow more system return water to be mixed into the boiler therefore supplying more hot water to the zones.

System Pressure

The Clean Burn CTB is designed to operate in closed, pressurized hydronic systems. Certain levels of pressure are required for proper system operation--**a minimum of 12 PSI should be maintained on the system where the boiler supply water temperature is 200 °F or less.** If a higher working pressure is required, contact the Clean Burn Service Department for proper pressure requirements.

Sample System Configuration: Primary/Secondary Pumping System

A sample hydronic system setup using Clean Burn Coil Tube Boilers is shown in Figure 10A. This system, a **Primary/Secondary Pumping System**, allows for many special hydronic requirements (e.g. water return temperatures below the normal 140 °F, variable flow zones, multiple zones, multi-temperature systems, and/or multiple boilers) and provides maximum flexibility while maintaining optimal system functioning. **A critical advantage of this type of system is that it dramatically reduces the danger of thermal shock to the boiler.**

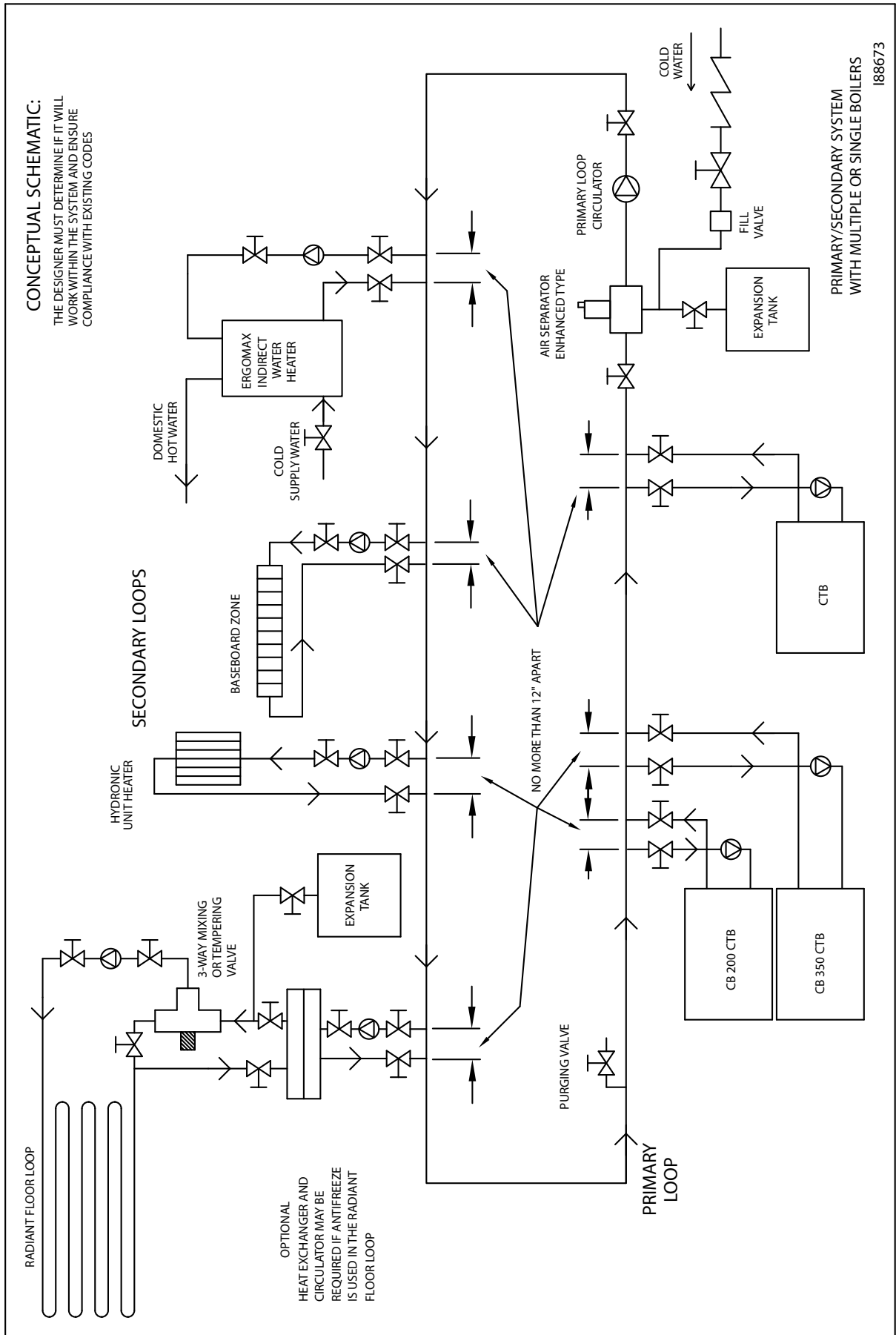

Figure 10A - Sample Primary/Secondary Hydronic System Diagram

CTB System Function and Configuration (continued)

In a Primary/Secondary Pumping System (as shown in Figure 10A), the primary loop circulator runs when any of the zones call for heat. In some system setups, the circulator may run continuously during the heating season. The circulator pushes hot water past the zone tees; any of the secondary zone pumps can draw hot water out of the first tee (as though the tee were a boiler). Each zone then returns cooler water through the second tee where it mixes with the hot water being pushed through by the primary loop circulator. **The close positioning of the two zone tees is crucial to the operation of the system; the tees must be at least 6" but not more than 12" apart.** This allows for circulators of different flow rates to be used in the same system while maintaining proper flow and functioning.

CTB Setup Options

When designing and setting up the CTB Hydronic System, please be aware of the following options and special setup requirements:

(1) *The boiler circulator (which you may have ordered from Clean Burn for your CTB system) is sized to ensure a flow of water through the coil tube ONLY;* it is NOT sized to be used as a system circulator. The boiler circulator must be installed according to Figures 10B and 10C, after the mixing valve. An additional circulator must be installed to flow water through the system and to the boiler.

(2) *In low load conditions,* Clean Burn recommends the installation of a larger storage tank next to the CTB to extend the run time and to reduce the occurrence of short cycling. Position the tank close to the boiler to reduce the required connective piping as shown in sample configuration, Figure 10B.

(3) *If hot water is required in the system installation for washing or other related activities,* Clean Burn offers **Ergomax Heat Exchangers/Storage Tanks in various sizes.** Contact your local Clean Burn representative for additional details on these CTB system components. Refer to Figure 10C for a sample system configuration using an Ergomax Heat Exchanger. This configuration is ideal for installations requiring pressure washing, car/truck washing, etc. The Ergomax unit works well with a CTB because it stores boiler water in the tank and acts as a buffer (tempering) tank while enabling reduction of short cycling.

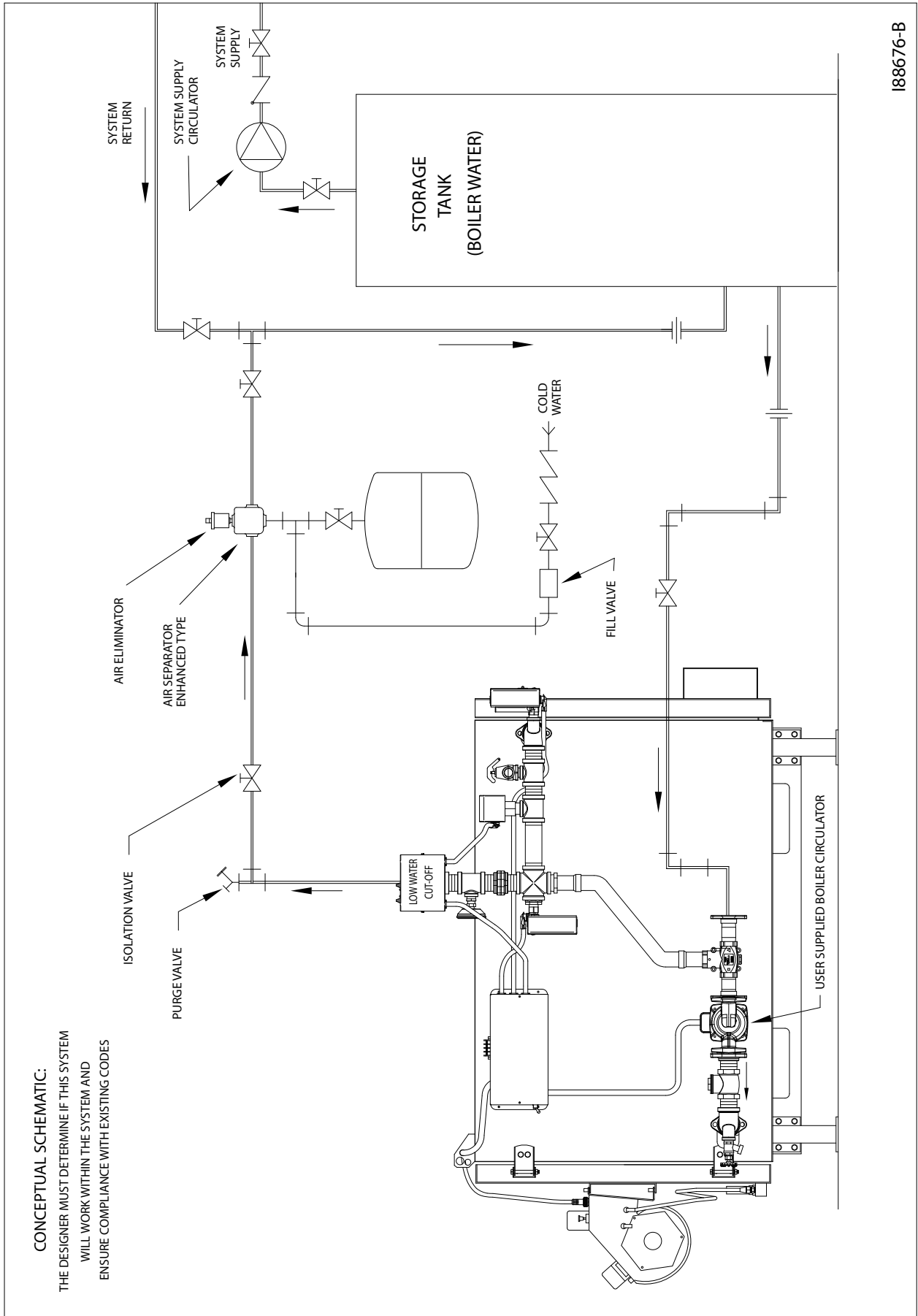

Figure 10B - CTB with Additional Larger Storage Tank

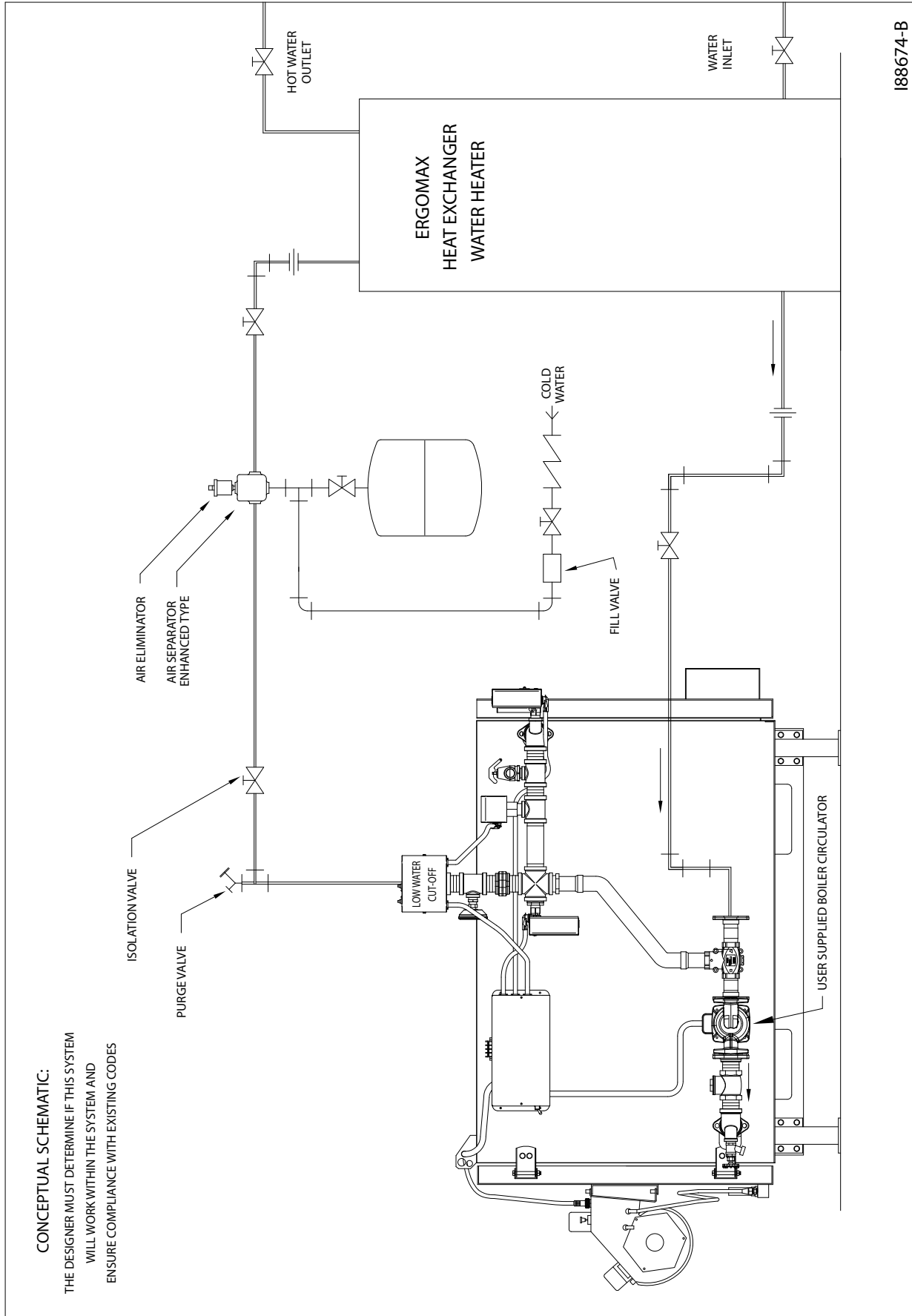

Figure 10C - CTB with Ergomax Indirect Water Heater

Guidelines for CTB Setup and Operation

1. Refer to the appropriate illustration in this section for your CTB system configuration, as well as Figures 4A/4B in the Installation chapter.
2. Connect the supply and return piping to the heating system. (Additional information in Section 4).



CAUTION: Hot water pipes shall have clearances of at least 1/2" from all combustible surfaces. For additional technical reference material, see I=B=R Installation and Piping Guide No. 200.

3. The relief valve must be installed with the spindle in the vertical position. The relief valve discharge pipe must be extended to within four inches of the floor or to a drain.
4. To reduce the amount of cold water returned to the boiler (and to protect the boiler from thermal shock), a return blend loop should be utilized.
5. Fill the entire heating system with water and vent air from the system according to the following instructions:

- (a) Close the isolation valve in the boiler supply piping.
- (b) Isolate all circuits by closing the zone valves or balancing valves.
- (c) Attach a hose to the purge valve located just below the isolation valve in the boiler supply piping.

NOTE: Ensure that the end of the hose drains into a bucket located in a drain area or outside.

- (d) Starting with one circuit, open the first zone valve ONLY.
- (e) Open the purge valve.
- (f) Open the fill valve (the make-up water line should be located on the system side of the isolation valve in the boiler supply piping.)
- (g) Allow water to overflow from the bucket until discharge from the hose is bubble-free.
- (h) Open the zone valve to the second zone to be purged, then close the first. Repeat this step until all zones have been purged, but always have one zone open. At completion, open all zone valves.
- (i) Close the purge valve, continue filling the system until the pressure gauge reads 12 psi. Close the fill valve.

NOTE: If the make-up water line is equipped with a pressure reducing valve, the system will automatically fill to 12 psi.

- (j) Open the isolation valve in the boiler supply piping.
- (k) Remove the hose from the purge valve.
- (l) As soon as the boiler is filled, heat the water in the boiler to 180 °F to de-aerate the water.

Guidelines for Preventing Oxygen Contamination

ATTENTION: Oxygen contamination of boiler water will cause corrosion of iron and steel boiler components, and can lead to boiler failure (and void warranty). Causes of oxygen contamination include:

- Addition of excessive make-up water as a result of system leaks
- Absorption through open tanks and fittings
- Oxygen permeable material in the distribution system

To ensure optimal CTB maintenance and operation, follow these recommendations to eliminate damaging oxygen contamination:

- Repair system leaks to eliminate the need for the addition of make-up water
- Eliminate open tanks from the system
- Eliminate and/or repair leaky fittings
- Use non-permeable materials in the distribution system
- Isolate the boiler from the water heater system (i.e. wash and potable waters) by installing a heat exchanger.

Guidelines for Initial Cleaning of the Hydronics System and Maintaining Water Quality

- Clean the boiler with an alkaline cleaner (e.g. soda ash or detergent) as recommended by a qualified water treatment company.
NOTE: This is necessary to remove oil or other coatings from the tube surfaces. These protective coatings are commonly applied to new tubes to prevent rusting during storage/transit and will cause corrosion if left on the tubes during operation of the boiler.
- After cleaning the boiler, drain the system in a manner and to a location that hot water can be discharged safely.
- Remove plugs from all available locations, and wash the water side of the boiler as thoroughly as possible using a high-pressure water stream.
- Refill the system with fresh water.
- Test the pH of the water in the system. The pH should be higher than 8.5 but lower than 9.5. Add appropriate boiler water treatment compounds as recommended by your qualified water treatment company (if necessary) to bring the pH within the specified range.
- Heat the water in the boiler to 180 °F to de-aerate the water.

Guidelines for CTB Operation

After proper and safe CTB burner setup and installation has been accomplished, CTB operation proceeds as follows:

- (a) Refer to Section 6 for instructions on starting the CTB.
- (b) Following burner startup, set the operating control dial at 180-200 °F.

ATTENTION: If, during normal operation, it is necessary to add water to your system more than once a year, consult a qualified service technician to check your system for leaks. A leaky system will increase the volume of make-up water supplied to the boiler which can significantly shorten the life of the boiler and cause damage to the boiler.

SECTION 11: TROUBLESHOOTING

The following charts and tables are provided for reference in troubleshooting any difficulties encountered in boiler operation and adjustment.

- The **Flow Chart** outlines the proper sequence of events in boiler operation -- use this chart to help diagnose where a problem may be occurring.
- More specific troubleshooting information is provided in the **Troubleshooting Tables** following the flow charts. Each table lists a **Problem**, **Possible Cause**, and **Possible Action(s)** to fix the problem.

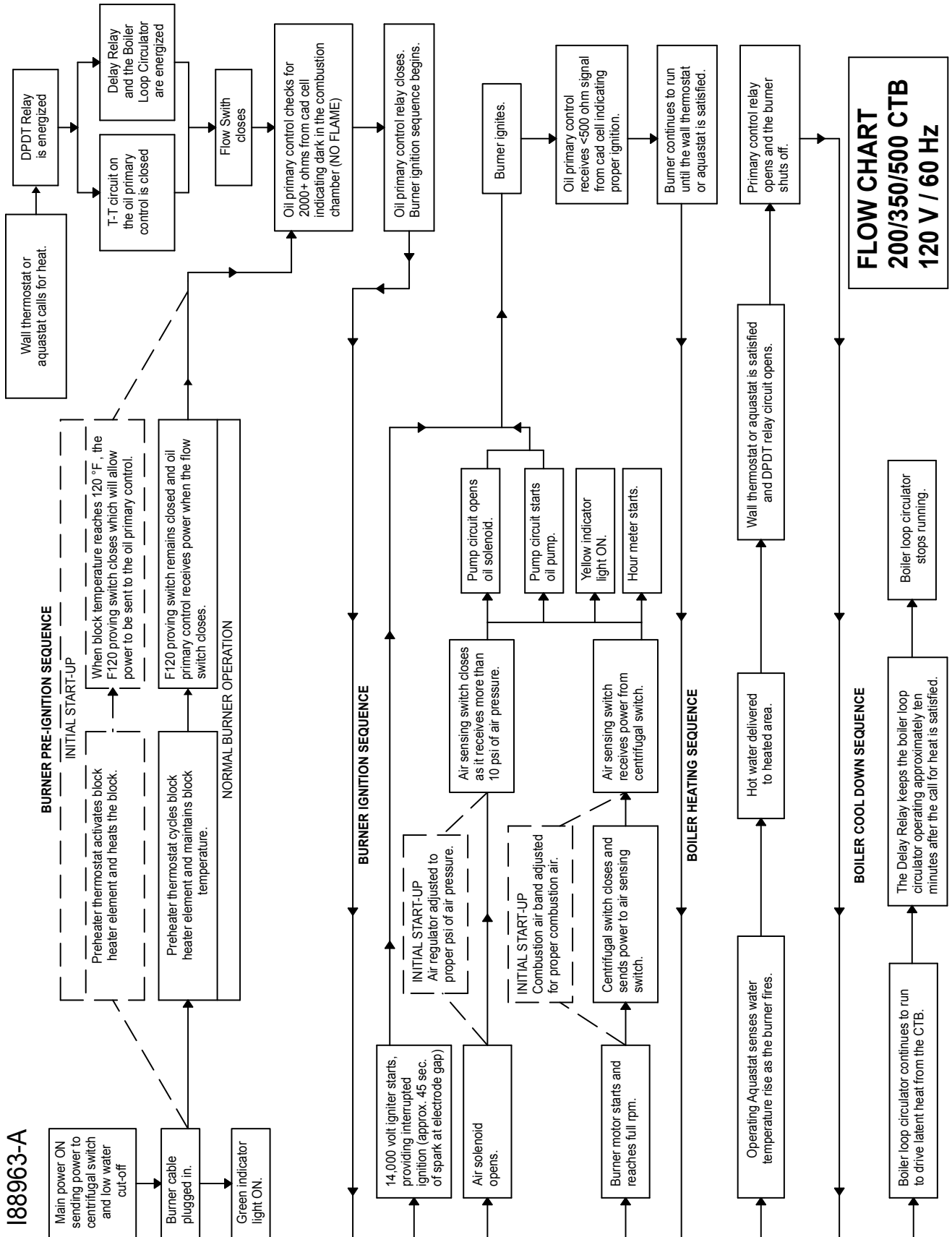

PROBLEM	POSSIBLE CAUSE(S)	POSSIBLE ACTION(S)
<p>Burner won't run at all and Green power light is NOT ON.</p>	<ol style="list-style-type: none"> 1. Circuit breaker/main switch open. 2. Fuse/breaker blown. 3. Burner cable is damaged or not plugged in properly. 	<ol style="list-style-type: none"> 1. Close circuit breaker/switch. 2. Electrician should check out electrical system. 3. Check burner cable.
<p>Burner won't run at all and Green power light is ON.</p>	<ol style="list-style-type: none"> 1. Oil primary control has shut down on safety reset. 2. Wall thermostat is not operating. 3. Heater block is not heating up. 4. F-120 proving switch has not closed. 5. Oil primary control terminals are not wired correctly. 6. Oil primary control is damaged. 7. The flow switch, operating aquastat, or high limit switch has opened. 	<ol style="list-style-type: none"> 1. Follow the directions in Section 7 to reset the oil primary control. 2. Check the wall thermostat and thermostat cable. 3. Feel the back of the burner; it should be 140 degrees F. If the heater block is NOT HOT: (a) Wait 15 minutes for the heater block to heat up and re-check the back of the burner, and (b) Check the block heater thermostat and block heater element. Refer to the wiring diagram and ladder schematic in Appendix B. 4. If the block is HOT: (a) Check the red wire at the F-120 proving switch for power. If there is NO power at the red wire, refer to the wiring diagram and ladder schematic in Appendix B to troubleshoot the circuit that provides power to the proving switch. (b) If there is power at the red wire at the proving switch, check for power at the black wire. If there is NO power at the black wire, replace the F-120 proving switch. 5. Check the oil primary control: (a) Check that the "F" terminals are NOT jumped. (b) Check that the two yellow cad cell wires are connected to the "F" terminals. (c) Check that the two thermostat wires are connected to the "T" terminals. 6. Replace oil primary control: (a) Check voltage – it must be 115 volts. 7. Test the switches for power. Note that power should be indicated on both sides of the switch.

PROBLEM	POSSIBLE CAUSE(S)	POSSIBLE ACTION(S)
<p>Burner ignites, but will not stay running and Burner shuts off on reset within 15 seconds.</p>	<ol style="list-style-type: none"> 1. There is a fuel delivery problem. 2. The cad cell is dirty. 3. Cad cell wires are loose. 4. Cad cell / cad cell wires are damaged. 5. The primary control is not receiving the proper ohm signal from the cad cell. 	<ol style="list-style-type: none"> 1. Follow the procedures listed in the next problem. 2. Clean and check the condition of the cad cell and cad cell wires. 3. Check that the yellow wires are connected properly at the "F" terminals on the oil primary control. 4. Replace the cad cell and cad cell wires. If the cad cell is heat damaged: (a) Clean your boiler, including the combustion chamber, flues and stack. Refer to instructions in Section 9. (b) Check for backdraft caused by exhaust fans in your building. Follow instructions in Section 8. 5. Disconnect the yellow wires from the "F" terminals. Start the burner and check the ohm reading from the cad cell. You have 10 seconds to perform this test before the burner shuts off on reset. Refer to Section 7 to reset the oil primary control. If the ohm reading is above 500 ohms: (a) Check the position of the cad cell; the cad cell must "look" straight through the central hole in the retention head. (b) Check the position of the retention head according to Appendix A.
<p>Burner ignites and runs properly, but the burner shuts off on reset periodically (e.g. the burner goes off on reset during the night and requires resetting in the morning).</p>	<ol style="list-style-type: none"> 1. There is air in the suction oil line due to leaks at the fittings 2. There is air trapped in a high point in the pressure oil line. 	<ol style="list-style-type: none"> 1. Follow the procedures in Section 5 to vacuum test the pump. Reinstall and properly seal the suction line fittings to eliminate air leaks. 2. Follow instructions in Section 4 to bleed the air out of the pressure oil line.

PROBLEM	POSSIBLE CAUSE(S)	POSSIBLE ACTION(S)
<p>Burner ignites and Burner shuts off on reset sometime later during the day or night.</p>	<ol style="list-style-type: none"> 1. There is air in the fuel supply. 2. The primary control is not receiving the proper ohm signal from the cad cell. 3. There is insufficient air pressure. 4. The heater block is cold. 5. The electrodes are fouled. 	<ol style="list-style-type: none"> 1. Prime the pump. If the pump will not prime or there is air in the oil stream from the pump bleeder, follow the steps in the next problem (“Pump will not prime.”) 2. Check for proper ohm signal. Follow the procedures in the previous problem (top, page 11-4 3. Follow the instructions in Section 5 to adjust the air regulator for proper air pressure. DO NOT turn the air compressor off while the boiler is operating. If you turn the air compressor off at night, turn the wall thermostat or aquastat OFF so the burner will not run. 4. DO NOT shut off power to the boiler overnight, or the heater block will cool down, and the burner will not re-start the next morning. To turn the boiler “off” overnight, turn the wall thermostat or aquastat OFF. The heater block will stay hot. 5. If oil residues have built up on the electrodes and retention head, follow the instructions in Section 8 to check for proper draft over fire. Clean the electrodes and retention head.

PROBLEM	POSSIBLE CAUSE(S)	POSSIBLE ACTION(S)
<p>Pump will not prime and Pump motor is running.</p>	<ol style="list-style-type: none"> 1. There is a leak(s) in the suction line. 2. The pump is not installed so it will fill with oil during the priming process. 3. The pump gears are dry. 4. The pump seal is damaged. 5. The ball valve is closed. 6. The canister filter is dirty. 7. The check valve is dirty. 8. The pump is damaged or worn out. 	<ol style="list-style-type: none"> 1. Follow the specifications in Section 4 to make sure the suction line is installed properly and that all fittings are 100% airtight. 2. Make sure the pump head is filled with oil prior to starting the pump. See Section 5. 3. Follow the procedure in Section 5 to fill the oil line and prime the pump. 4. With the pump not running, wipe your finger along the bottom of the cylinder at the pump shaft. If there is oil at the pump shaft, the seal is damaged. Replace the pump, or replace the seal. NOTE: Some oils will expand as they warm up. Because there is a check valve in the suction line, the expanding oil may build up pressure and damage the oil seal. Install a mini-accumulator in the 1/8" port of the canister filter to prevent the pressure build-up. 5. Open the ball valve on the suction line. 6. Refer to Section 9 to clean the canister filter. 7. Refer to Section 9 to clean the check valve. 8. Replace the pump.

APPENDIX A

Detailed Coil Tube Boiler Specifications

CTB Technical Specifications

Model	CB-200-CTB	CB-350-CTB	CB-500-CTB
BTUH Input	200,000*	350,000*	500,000*
Listed Fuels: <ul style="list-style-type: none"> • #2 Fuel Oil • Used Crankcase Oil • Used ATF • Used Hydraulic Oil • #4, #5 Fuel Oils 	1.4	2.5	3.57
Water Volume (gallons)	5 gal.	12 gal.	20.6 gal.
Cabinet Dimensions (LxWxH)	40 x 29 x 29.5"	56 x 34 x 34.5"	66.38 x 40 x 42"
Overall Length (with burner/breach)	59"	74"	86.13"
Approximate Weight	677 lbs. (dry)	1240 lbs. (dry)	1600 lbs. (dry)
Mounting	Non-Combustible Floor	Non-Combustible Floor	Non-Combustible Floor
Electrical Requirements (VAC @ 60 Hz)	115	115	115
Circuit Breaker	15 amps**	20 amps**	20 amps**
Approximate Amp Draw	9	10	12
Max. Oil Consumption	1.4 GPH	2.5 GPH	3.57 GPH
Oil Pump	Suntec A2RA-7720	Suntec A2RA-7720	Suntec A2RA-7720
Oil Pump Motor	Bison Gear Motor 1/20 HP	Bison Gear Motor 1/20 HP	Bison Gear Motor 1/20 HP
Pump Motor Rotation	CCW shaft end	CCW shaft end	CCW shaft end
Canister Filter	Lenz DH 750-100	Lenz DH 750-100	Lenz DH 750-100
Stack Size	8"	8"	10"
Approx. Air Compressor Requirements	2.0 CFM @ 25 PSI	2.5 CFM @ 25 PSI	2.5 CFM @ 25 PSI

*Nominal values; actual values will vary depending on installation.

** With optional accessories, 30 amps may be required.

Burner Technical Specifications

Model	CB-200-CTB	CB-350-CTB	CB-500-CTB
Burner	CB-525-S2	CB-551-H3	CB-551-H5
Ignition Transformer	Carlin 14,000 Volts	Carlin 14,000 Volts	Carlin 14,000 Volts
Nozzle	Delavan 9-5	Delavan 9-5	Delavan 9-28
Burner Motor	1/10 HP 3000 rpm w/ Centrifugal Switch)	1/10 HP 3000 rpm w/ Centrifugal Switch)	1/10 HP 3000 rpm w/ Centrifugal Switch)
Burner Motor Rotation	CCW shaft end	CCW shaft end	CCW shaft end
Compressed Air Requirements	2.0 CFM @25 PSI	2.5 CFM @25 PSI	2.5 CFM @25 PSI
Oil Primary Control	Carlin Oil Primary 402 w/ Interrupted Ignition)	Carlin Oil Primary 502 w/ Interrupted Ignition)	Carlin Oil Primary 502 w/ Interrupted Ignition)
Heater Element in Preheater Block	400 Watts	400 Watts	500 Watts
Air Pressure Switch	MPL 808	MPL 808	MPL 808
Heater Thermostat	140 oF	140 oF	160 oF

CB-200-CTB Hydronic Specifications

NOTE: These specifications apply for each CTB unit or coil.

- Water flow through the boiler:
15 GPM at 20 -22 ft. of head (pressure)
- 20 °F temperature rise (ΔT)
- ASME coil length: 112 ft. long, 1" diameter steel tubing made to Sch. 40 pipe size
- Coil Volume: 5 Gallons
- Coil Dry Weight: 189 lbs.
- System operating pressure: 12 to 22 psi
- Standard relief valve setting: 30 psi
- Relief valve capacity: 550 MBH
- Heating surface: 38.7 sq. ft.
- Factory Recommended Boiler Circulator:
TACO 0011

CB-350-CTB Hydronic Specifications

NOTE: These specifications apply for each CTB unit or coil.

- Water flow through the boiler:
25 GPM at 18-20 ft. of head (pressure)
- 20 °F temperature rise (ΔT)
- ASME coil length: 158 ft. long, 1-1/4" diameter steel tubing made to Sch. 40 pipe size
- Coil Volume: 12.3 Gallons
- Coil Dry Weight: 359 lbs.
- System operating pressure: 12 to 22 psi
- Standard relief valve setting: 30 psi
- Relief valve capacity: 710 MBH
- Heating surface: 68 sq. ft.
- Factory Recommended Boiler Circulator:
B&G PL36
B&G PL55 (over 20 ft. of head)

CB-500-CTB Hydronic Specifications

NOTE: These specifications apply for each CTB unit or coil.

- Water flow through the boiler:
37 GPM at 22 ft. of head (pressure)
- 20 °F temperature rise (ΔT)
- ASME coil length: 195 ft. long, 1-1/2" diameter steel tubing made to Sch. 40 pipe size
- Coil Volume: 20.63 Gallons
- Coil Dry Weight: 530 lbs.
- System operating pressure: 12 to 22 psi
- Standard relief valve setting: 30 psi
- Relief valve capacity: 970 MBH
- Heating surface: 97 sq. ft.
- Factory Recommended Boiler Circulator:
TACO 2400-50/2

CTB Accessories and Parts Reference

C.B. Part #			Description
<u>500-CTB</u>	<u>350-CTB</u>	<u>200-CTB</u>	
11578	90187	90199	Boiler Stacking Adapter Kit
90206	90188	90200	Boiler Stand (base)
		11095	Circulator, TACO 0011, 115VAC
	35078		Circulator, B&G PL-36, 115VAC
	35112		Circulator, B&G PL-55, 115VAC
35130			Circulator, TACO 2400-50/2 115VAC
	35080	35080	B&G Circulator Flange Gasket O-Ring
35134			TACO Circulator 500 Flange Gasket O-Ring
		35116	Flange, 1" NPT
	35061		Flange, 1-1/2 NPT
	35079	35079	Flange, 1-1/4 NPT
35120			TACO Flange, 500 2" NPT Set
35121			TACO Flange, 500 1-1/2" NPT Set
	35053	35053	Flange Gasket, 3-hole
35125			500 Flange Gasket, 3-hole
28150	28150	28150	Operating Aquastat, L4006A
35110	35110	35110	Electronic Low Water Cut-Off with Probe, 750P-MT-120
35111	35111	35111	Probe (only) for Low Water Cut-Off
28149	28149	28149	High Temperature Cut-off, L4006H
35123	35123	35123	Taco Flow Switch (without paddle)
35124	35124	35124	Stainless Steel Paddle for Taco Flow Switch (sized to fit)
	35117		Stainless Steel Paddle for M&M Flow Switch (sized to fit)
33330	33330	33330	Temp-Pressure Boiler Gauge
35136	35135	35048	Relief Valve, 30 PSI
35049	35049	35049	Well Immersion, 3/4" NPT

Ergomax Indirect Water Heater (Heat Exchangers)*

**Contact the CB Parts/Service Department for help in specifying the appropriate model.*

35113	E23	
35096	E24	
35097	E44	
35098	E45	
35099	E65	
35100	E109	
35107	Air Separator, EAS - 1-1/2	(1-1/2" piping with air vent)
35108	Air Separator, EAS -2	(2" piping with air vent)

Remote Temperature Controls

33557	Wall Thermostat
-------	-----------------

CTB Dimensions

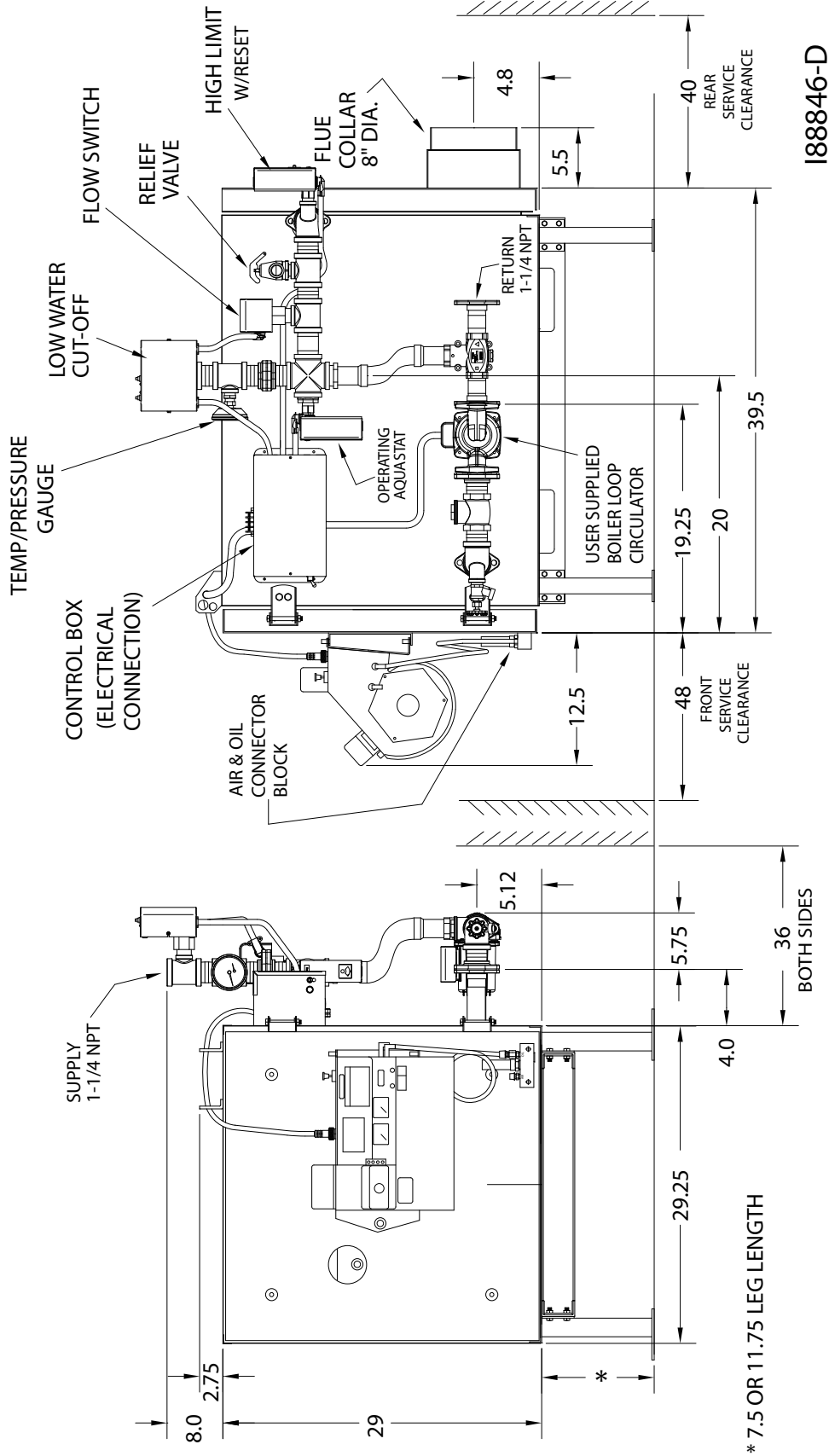
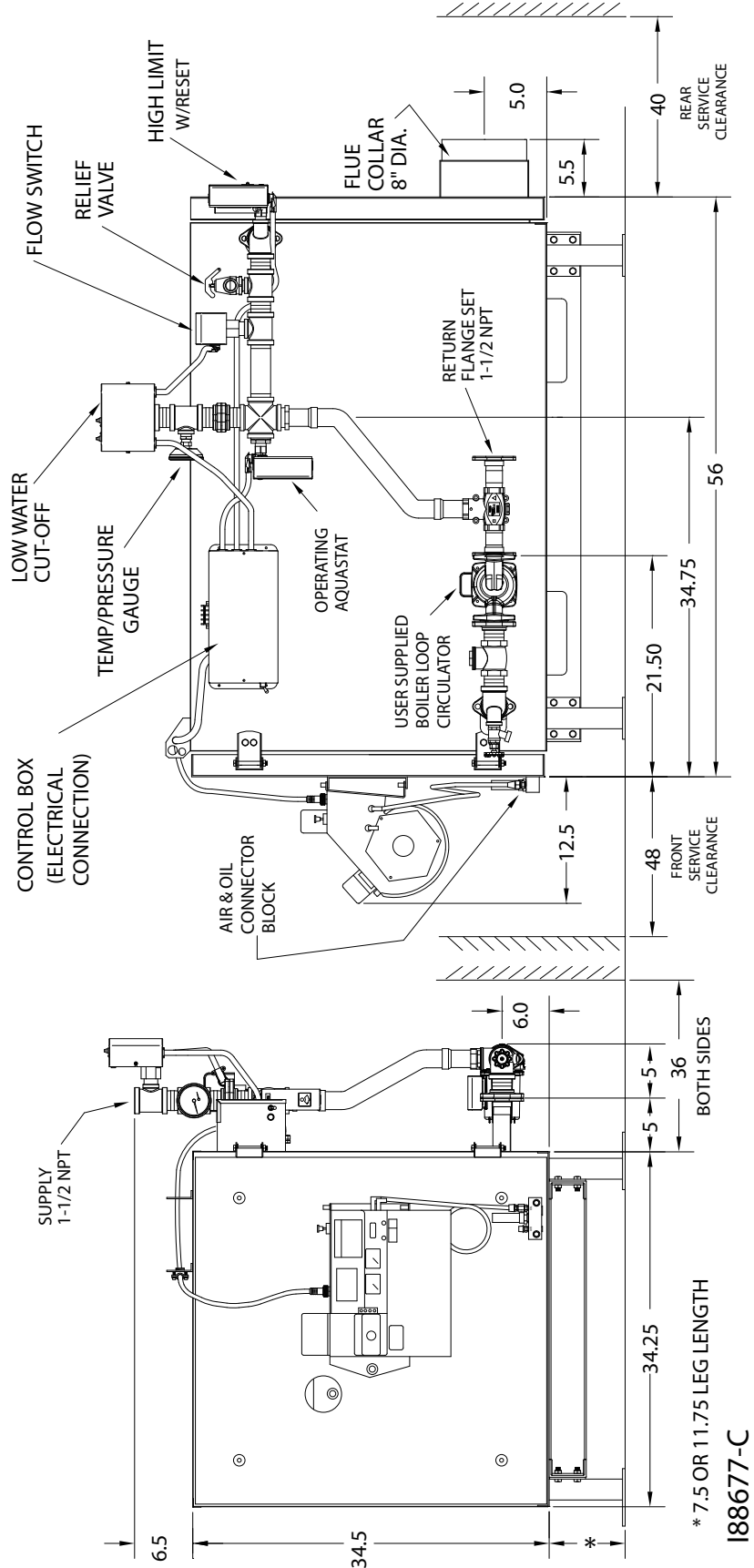

Figure A1 - Model CB-200-CTB Dimensions (Single Boiler)

CTB Dimensions



* 7.5 OR 11.75 LEG LENGTH
188677-C

Figure A2 - Model CB-350-CTB Dimensions (Single Boiler)

CTB Dimensions

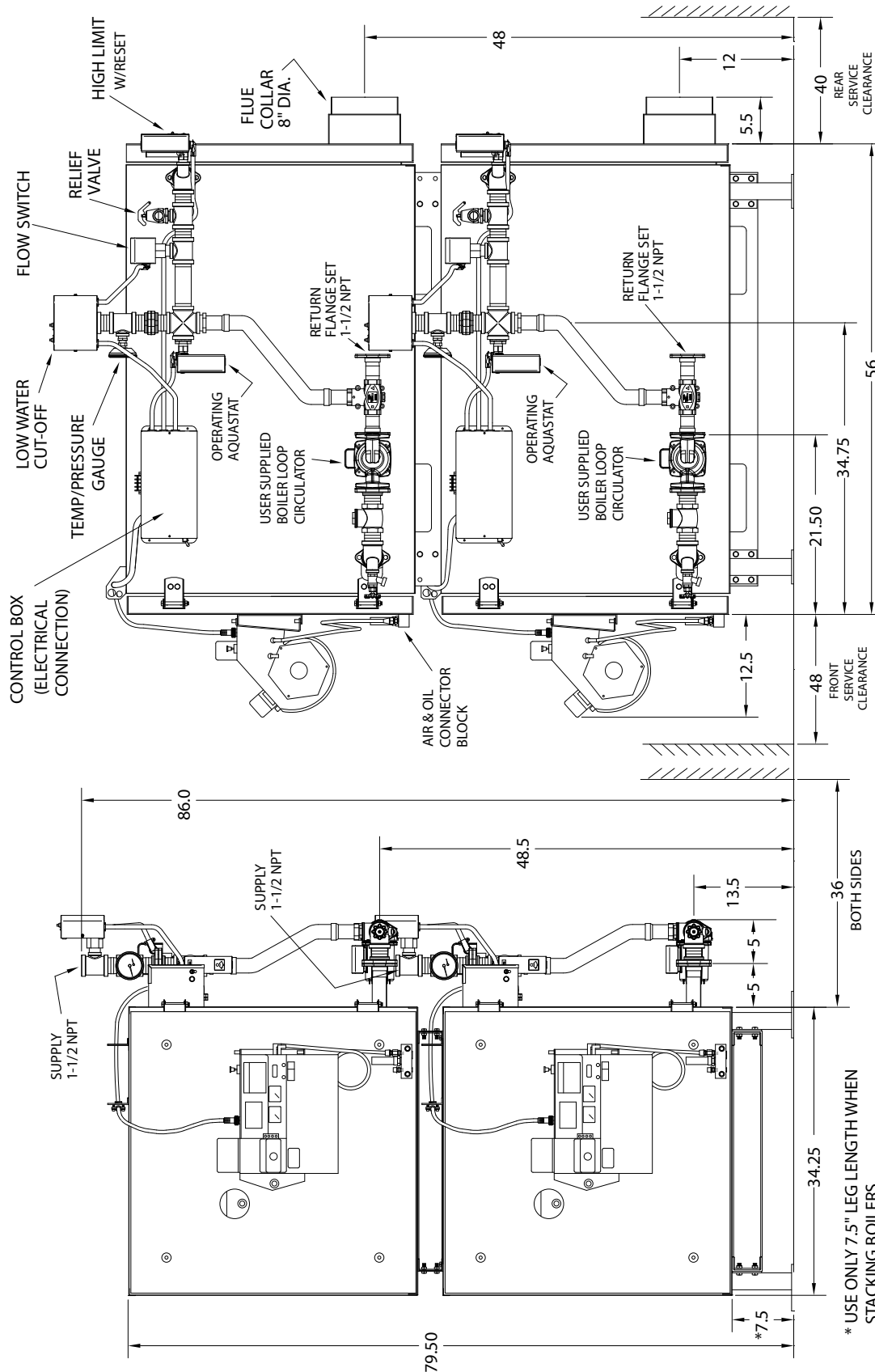

188678-C

Figure A4 - Dual-Stacked Boiler Dimensions (Two CB-350-CTB Boilers)

CTB Dimensions

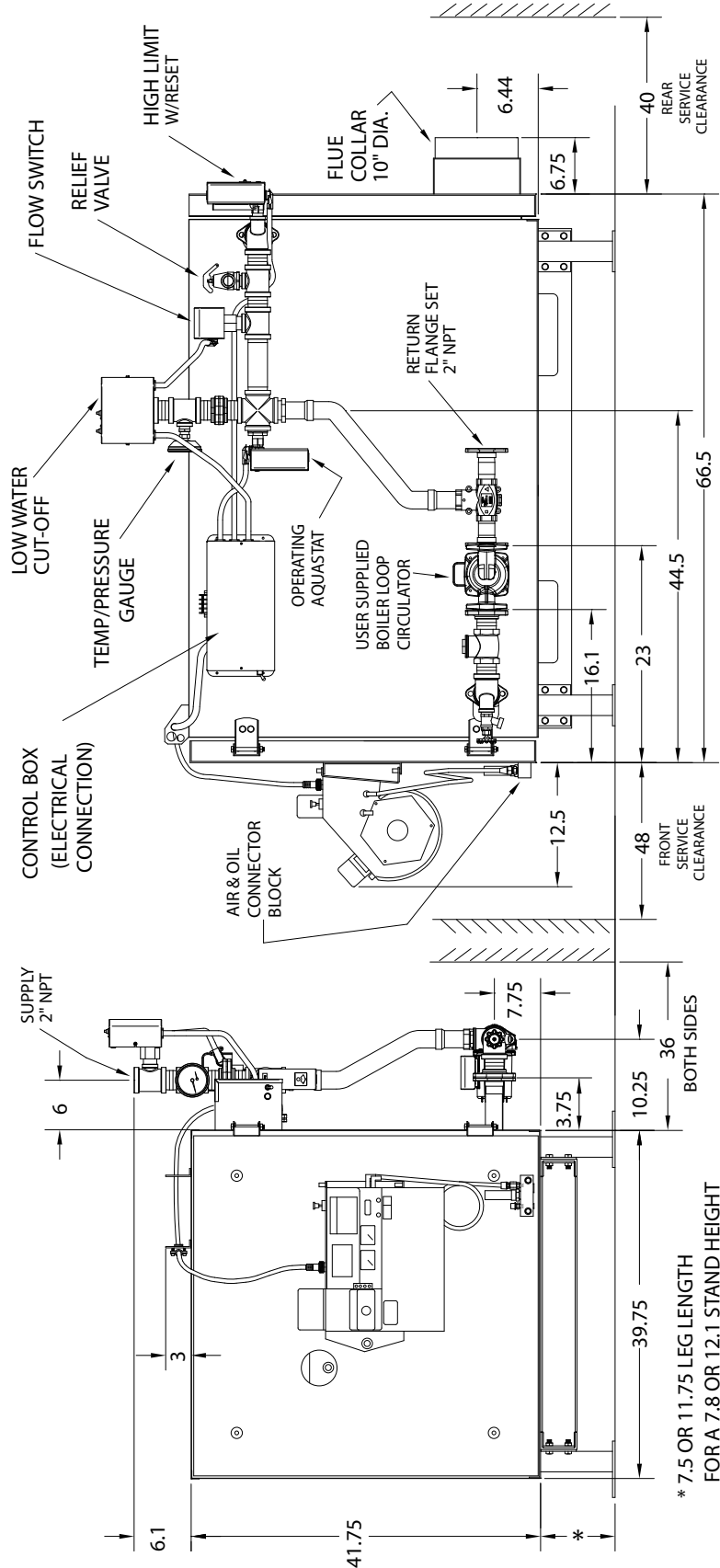

Figure A3 - Model CB-500-CTB Dimensions

CTB Dimensions

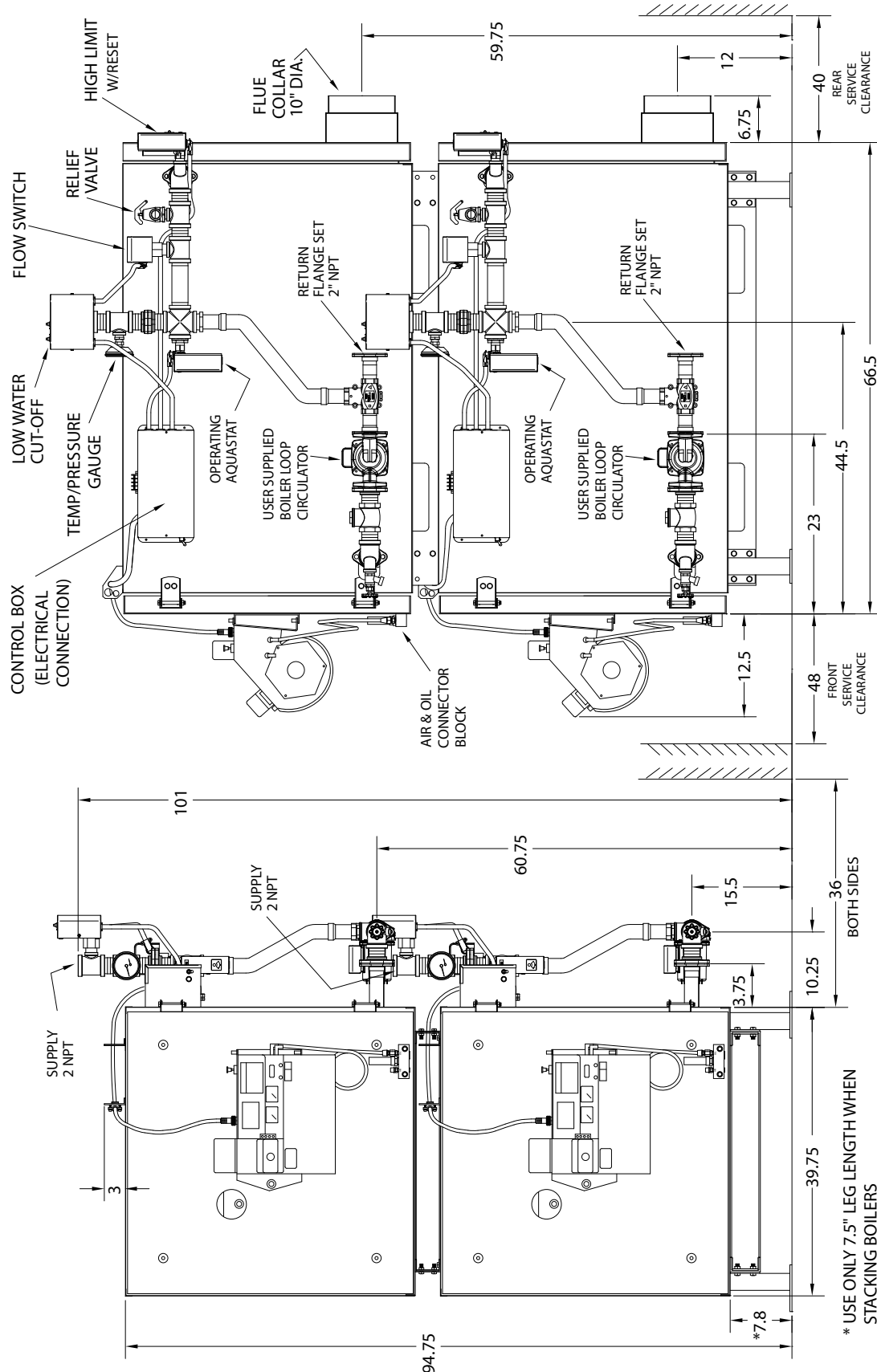
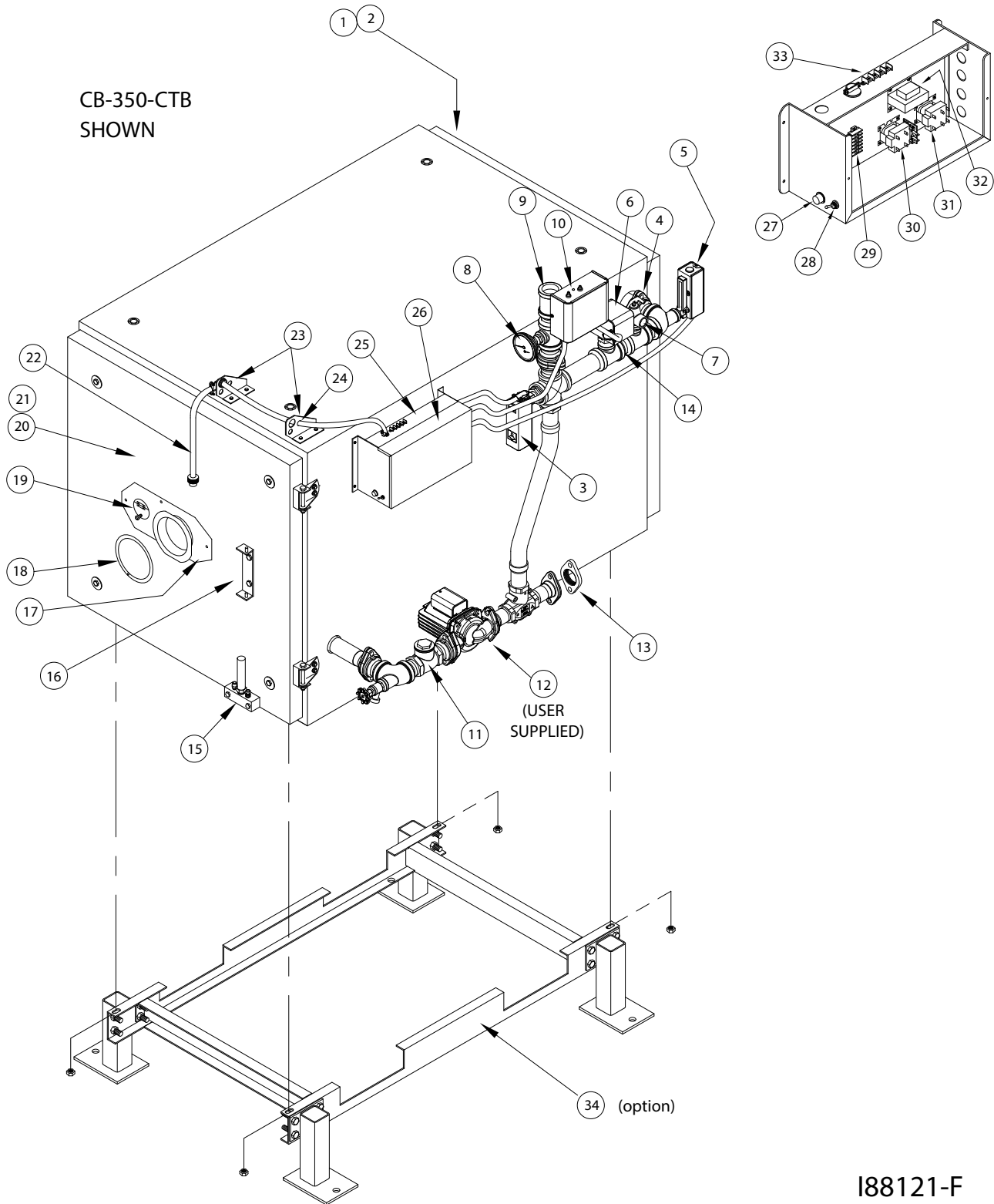

Figure A4 - Dual-Stacked Boiler Dimensions (Two CB-500-CTB Boilers)

Single Boiler Assembly



I88121-F

Figure A5 - Single Boiler Assembly Component Detail

Coil Tube Boiler Operator's Manual: Models CB-200-CTB, CB-350-CTB, and CB-500-CTB

CB-350-CTB PARTS LIST			
NUMBER	QTY	PART #	DESCRIPTION
34	1	90188	BASE
33	1	33331	TERMINAL BLOCK
32	1	33327	TRANSFORMER 120V-24V
31	1	33328	RELAY DPDT
30	1	33352	RELAY DELAY
29	1	33486	TERMINAL BLOCK ASSEMBLY
28	1	33286	SWITCH DPDT
27	1	33168	AMBER LIGHT
26	1	27058	CONTROL BOX LID
25	1	12240	CONTROL BOX 120 AC
24	1	33105	SNAP IN BUSHING
23	2	27158	L-BRACKET
22	1	33546	CONNECTOR CORD
21	1	31176	INSULATION - DOOR
20	1	11405	DOOR W.A.
19	1	21077	PORT LID
18	1	14084	ROPE GASKET
17	1	11583	BURNER MOUNT W.A.
16	1	11582	HINGE BRACKET W.A.
15	1	13141	ACCUMULATOR BLOCK ASSEMBLY
14	1	14272	UPPER PIPE ASSEMBLY
13	1	35061	1-1/2" FLANGE
12	1	35078	CIRCULATOR PL36 115V 60Hz
11	1	14293	CHECK VALVE AND PIPE ASSEMBLY
10	1	13110	LOW WATER CUT-OFF
9	1	14274	LOW WATER PIPE ASSEMBLY
8	1	33330	GUAGE BOILER TEMP/PRESS
7	1	35048	RELIEF VALVE 3/4" MALE
6	1	35123	FLOW SWITCH TACO
5	1	28149	HIGH TEMP CUT-OFF
4	1	35079	COIL FLANGE 1-1/4"
3	1	28150	AQUASTAT
2	1	31166	INSULATION PANEL
1	1	11380	PANEL 350 REAR W.A.

PARTS THAT DIFFER ON THE CB-200-CTB			
NO	QTY	PART #	DESCRIPTION
34	1	90200	BASE
22	1	33508	CONNECTOR CORD
21	1	31216	INSULATION 200 DOOR
20	1	11540	DOOR W.A.
14	1	14300	UPPER PIPE ASSEMBLY
13	1	35079	1-1/4" FLANGE
12	1	11095	CIRCULATOR TACO 0011 115 V
11	1	14298	CHECK VALVE AND PIPE ASSY
9	1	14299	LOW WATER PIPE ASSEMBLY
4	1	35116	COIL FLANGE 1" NPT
2	1	31215	INSULATION PANEL
1	1	11539	PANEL 200 REAR W.A.

PARTS THAT DIFFER ON THE CB-500-CTB			
NO	QTY	PART #	DESCRIPTION
34	1	90206	BASE
22	1	33546	CONNECTOR CORD
21	1	31240	INSULATION 500 DOOR
20	1	11564	DOOR W.A.
14	1	14315	UPPER PIPE ASSEMBLY
13	1	35120	FLANGE 2" SET
12	1	35130	CIRCULATOR TACO 2400-50/2 115V
11	1	14314	CHECK VALVE AND PIPE ASSY
9	1	14313	LOW WATER PIPE ASSEMBLY
4	1	35121	FLANGE 1-1/2" SET
2	1	31239	INSULATION PANEL
1	1	11563	PANEL 500 REAR W.A.

	200-CTB	350-CTB	500-CTB
Refractory Cylinder	21120	21140	21174
Refractory Cylinder Stand	27155	27190	27200

Burner Components CB-200-CTB

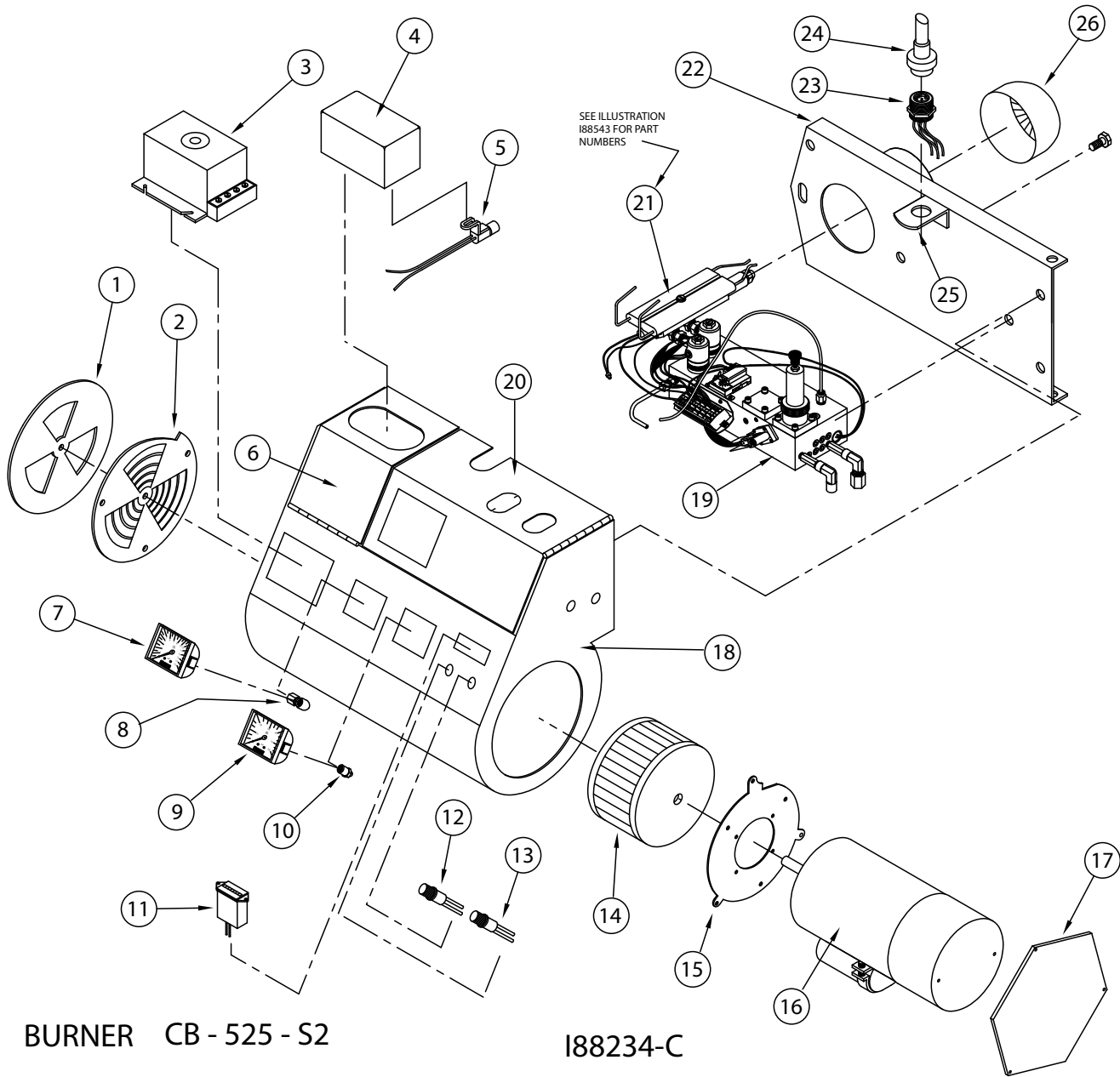

Figure A6 - CB-525-S2 Burner Component Detail (CB-200-CTB)

Burner Components CB-200-CTB((continued)

<u>Item#</u>	<u>Clean Burn Part#</u>	<u>Component Description</u>
1	26103	AIR INTAKE OUTER PLATE
2	11359	AIR INTAKE INNER PLATE
3	33400	CARLIN PRIMARY CONTROL (W/ INTERRUPTED IGNITION)
4	33335	ISOLATOR (OPTIONAL)
5	33189	CARLIN IGNITER (TRANSFORMER)
6	33116	CAD CELL
7	11243	TRANSFORMER PLATE
8	32178	OIL GAUGE 0-15 PSI
9	32235	FEMALE ELBOW (3/16 T x 1/8 NPT)
10	32179	AIR GAUGE 0-60 PSI
11	32253	FEMALE ELBOW (1/8 TP x 1/8 NPT)
12	33297	HOUR METER (60 Hz)
13	33169	GREEN LIGHT (POWER)
14	33168	AMBER LIGHT (PUMP)
15	31113	FAN SQUIRREL CAGE
16	26044	MOTOR MOUNT PLATE
17	33175	BLOWER MOTOR
18	26053	RIGHT SIDE COVER
19	11335	HOUSING (INCLUDES ITEM 23)
20	13148	HEATER BLOCK ASSEMBLY
21	11265	COVER-HINGED
22	SEE NOTE	NOZZLE ADAPTER ASSEMBLY
23	11334	HINGE MOUNTING PLATE
24	33149	CONNECTOR RECEPTACLE
25	33508	CONNECTOR CORD (CB-200-CTB)
26	26052	LATCH BRACKET
27	11308	RETENTION HEAD

Burner Components CB-350-CTB

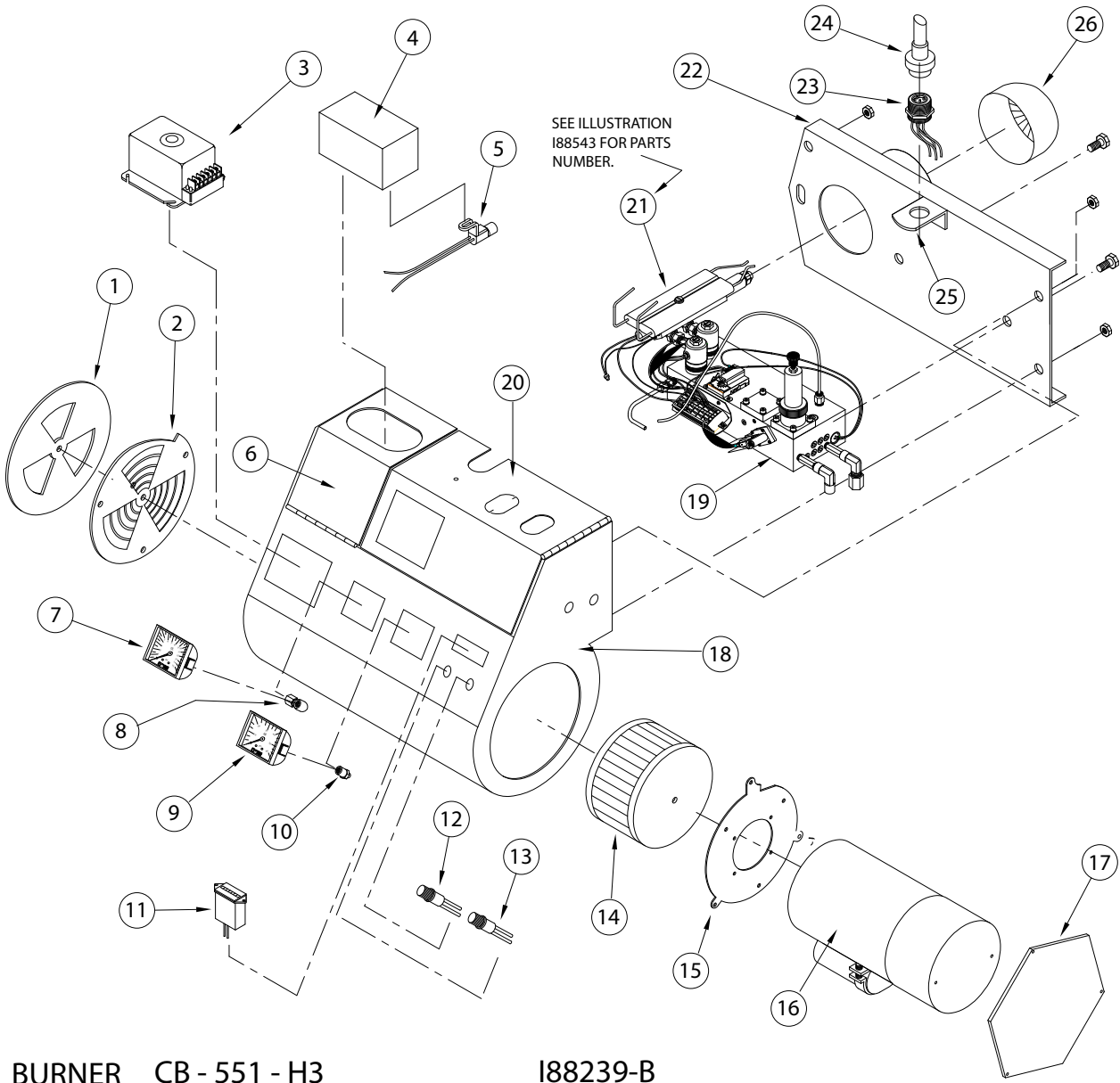
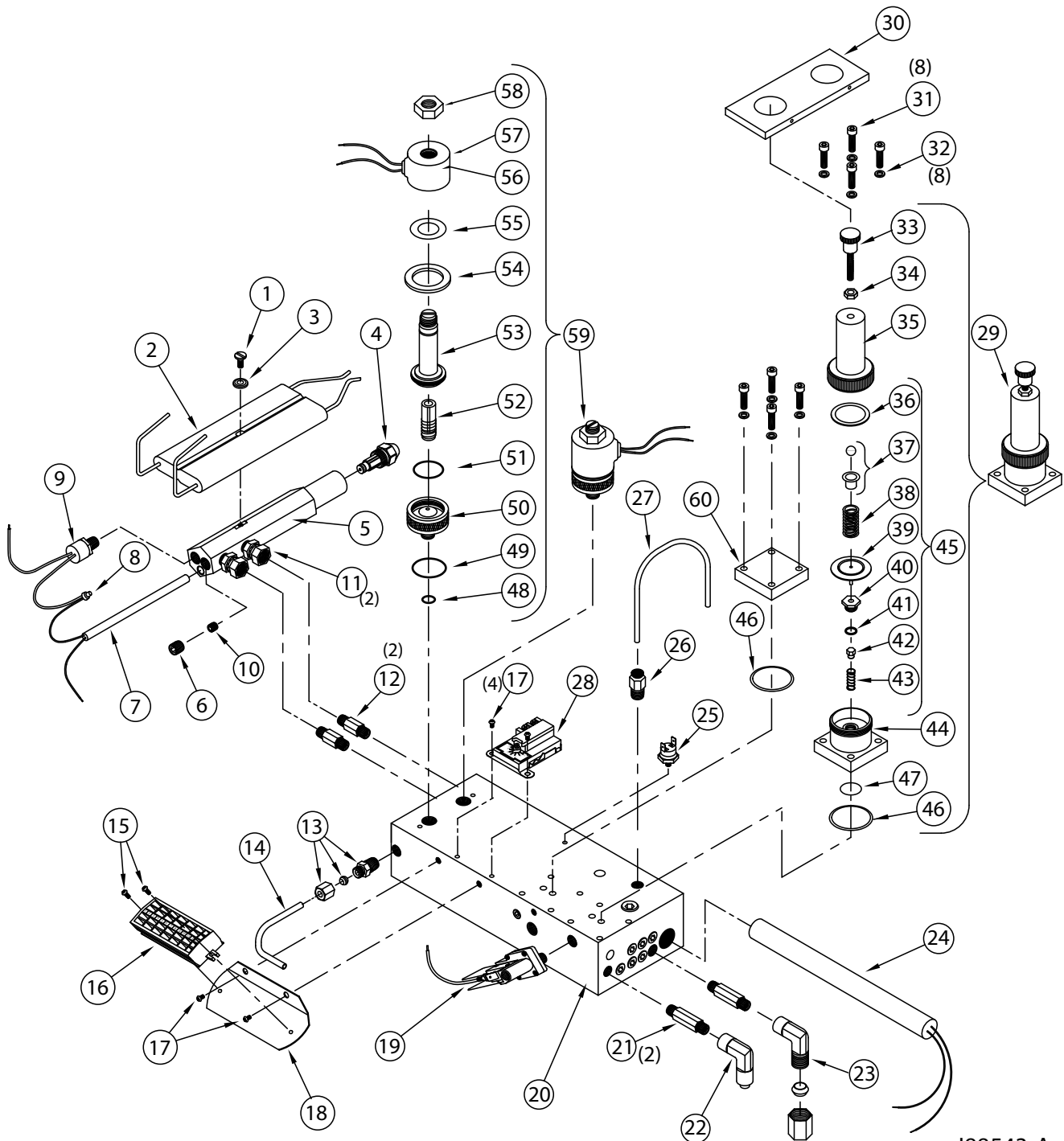

Figure A7 - CB-551-H3 Burner Component Detail (CB-350-CTB)

Burner Components CB-350-CTB (continued)

<u>Item#</u>	<u>C. B. Part#</u>	<u>Component Description</u>
1	26103	Air Intake Outer Plate
2	11359	Air Intake Inner Plate
3	33610	Electronic Primary Control (w/ Interrupted Ignition)
4	33189	Carlin Igniter (Transformer)
5	33116	Cad Cell
6	11243	Transformer Plate
7	32178	Oil Gauge, 0-15 psi
8	32235	Female Elbow, 3/16T x 1/8 NPT
9	32179	Air Gauge, 0-60 psi
10	32253	Female Elbow, 1/8TP x 1/8 NPT
11	33297	Hour Meter, 60 Hz
12	33169	Green Light (Power)
13	33168	Amber Light (Pump)
14	31113	Fan Squirrel Cage
15	26044	Motor Mounting Plate
16	33175	Blower Motor
17	14085	Right Side Cover
18	11335	Housing (includes item 23)
19	13148	Heater Block Assembly
20	11265	Cover, Hinged
21	SEE NOTE	Nozzle Adapter Assembly
22	11334	Hinged Mounting Plate
23	14088	Connector Receptacle
24	33546	Connector Cord (CB-350/500 CTB)
25	26052	Latch Bracket
26	11376	Retention Head

Burner Components (continued)



188543-A

**Figure A8 - Preheater Block and Electrode Assembly Component Detail
CB-525-S2 and CB-551-H3 Burners (CB-200-CTB and CB-350-CTB)**

Coil Tube Boiler Operator's Manual: Models CB-200-CTB, CB-350-CTB, and CB-500-CTB

<u>Item#</u>	<u>C.B. Part#</u>	<u>Qty.</u>	<u>Component Description</u>
1	34169	1	ELECTRODE SCREW - 10-32 x 3/4
2	33183	1	SINGLE PIECE ELECTRODE
3	34165	1	WASHER
4	32000	1	9 - 5 NOZZLE
5	13150	1	NOZZLE ADAPTOR
6	32007	1	PLUG - 1/8 NPT
7	33298	1	140 WATTS HEATER
8	33381	1	INSULATED CAP CRIMP CONNECTOR
9	33418	1	THERMOSTAT L-130
10	32199	1	PLUG - 1/16 NPT
11	32050	2	SWIVEL FITTING
12	32189	2	HEX NIPPLE - 1/8 NPT x 1-1/2
13	32043	1	MALE CONNECTOR - 3/16T x 1/8 NPT
14	54020	1	3/16 COPPER TUBING(OIL GAUGE LINE)
15	32201	2	MACH. SCREW PHILLIPS HD. 6-32 x 3/8 Z
16	33247	1	TERMINAL BLOCK
17	34036	4	MACH. SCREW PHILLIPS HD. 6-32 x 1/4 Z
18	26059	1	TERMINAL BLOCK BRACKET
19	33057	1	AIR PRESSURE SWITCH
20	26090	1	HEATER BLOCK
21	32190	2	HEX NIPPLE - 1/8 NPT x 2
22	32202	1	FEMALE ELBOW (FOR 1/4" AIR LINE)
23	32201	1	FEMALE ELBOW (FOR 3/8" OIL LINE)
24	33173	1	PRE-HEATER ELEMENT - 400 WATTS
25	33041	1	PROVING SWITCH (NORMALLY OPEN)
26	32325	1	MALE ELBOW 1/8 x 1/8 NPT (FOR AIR GAUGE LINE)
27	54020	1	3/16 COPPER TUBING(OIL GAUGE LINE)
28	33011	1	HEATER BLOCK THERMOSTAT(NORMALLY CLOSED)
29	32359	1	REGULATOR SURFACE MOUNT
30	14090	1	REGULATOR LOCK PLATE
31	34148	8	REGULATOR MOUNTING SCREW
32	34114	8	LOCK WASHER #8 Z
33	34147	2	REGULATOR THREADED STEM
34	34022	2	HEX NUT - 10-32 Z
35	32306	2	BONNET
36	32226	2	DIAPHRAM RING
37	32364	2	CAP AND BALL ASSEMBLY
38	32227	2	COMPRESSION SPRING
39	32360	2	DIAPHRAM
40	32361	2	BRASS POPPET SEAT
41	32223	2	POPPET 'O' RING
42	32222	2	POPPET VALVE
43	32221	2	POPPET SPRING
44	32362	2	BASE
45	13142	2	REGULATOR KIT COMPONENTS
46	32308	2	REGULATOR OUTER "O" RING
47	32309	2	REGULATOR INNER "O" RING
48	33311	2	SOLENOID INNER "O" RING
49	33312	2	SOLENOID OUTER "O" RING
50	33313	2	MANIFOLD MOUNT SOLENOID BODY
51	33314	2	BODY "O" RING
52	33315	2	PLUNGER ASSEMBLY
53	33316	2	PLUNGER GUIDE ASSEMBLY
54	33317	2	FLUX PLATE
55	33318	2	WASHER SEAL
56	33319	2	COIL
57	33320	2	COIL HOUSING
58	33321	2	NUT
59	32322	2	AIR/OIL SOLENOID ASSEMBLY
60*	26107	1	REG. SQUARE CAP*

***NOTE:** When the CTB is used with a metering pump, the oil regulator must be removed from the burner and replaced with the square cap.

Burner Components CB-500-CTB

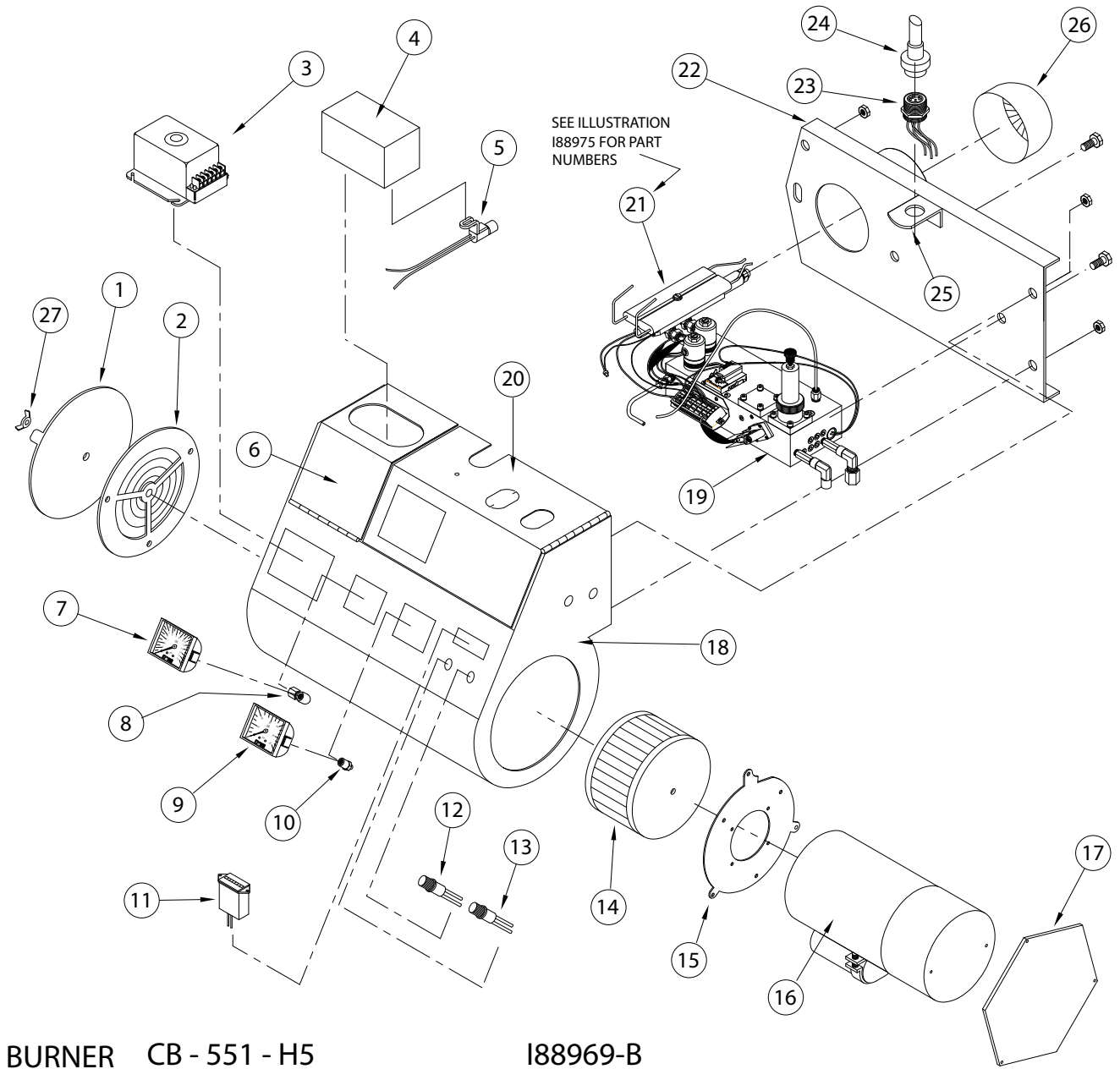

Figure A9 - CB-551-H5 Burner Component Detail (CB-500-CTB)

Burner Components CB-500-CTB (continued)

<u>Item#</u>	<u>C. B. Part#</u>	<u>Component Description</u>
1	11585	Air Intake Outer Plate
2	11584	Air Intake Inner Plate
3	33610	Electronic Primary Control (w/ Interrupted Ignition)
4	33189	Carlin Igniter (Transformer)
5	33116	Cad Cell
6	11243	Transformer Plate
7	32178	Oil Gauge, 0-15 psi
8	32235	Female Elbow, 3/16T x 1/8 NPT
9	32179	Air Gauge, 0-60 psi
10	32253	Female Elbow, 1/8TP x 1/8 NPT
11	33297	Hour Meter, 60 Hz
12	33169	Green Light (Power)
13	33168	Amber Light (Pump)
14	31113	Fan Squirrel Cage
15	26044	Motor Mounting Plate
16	33175	Blower Motor
17	14085	Right Side Cover
18	11335	Housing (includes item 23)
19	13179	Heater Block Assembly
20	11265	Cover, Hinged
21	SEE NOTE	Nozzle Adapter Assembly
22	11334	Hinged Mounting Plate
23	14088	Connector Receptacle
24	33546	Connector Cord (CB-350/500 CTB)
25	26052	Latch Bracket
26	11376	Retention Head
27	34417	Wing Nut 5/16

Note: When installing the blower and motor into the burner housing, the blower wheel needs to be adjusted to reduce the air gap between the side and the wheel to a maximum of 3/32" (.09375")

CB-551-H5 Heater Block

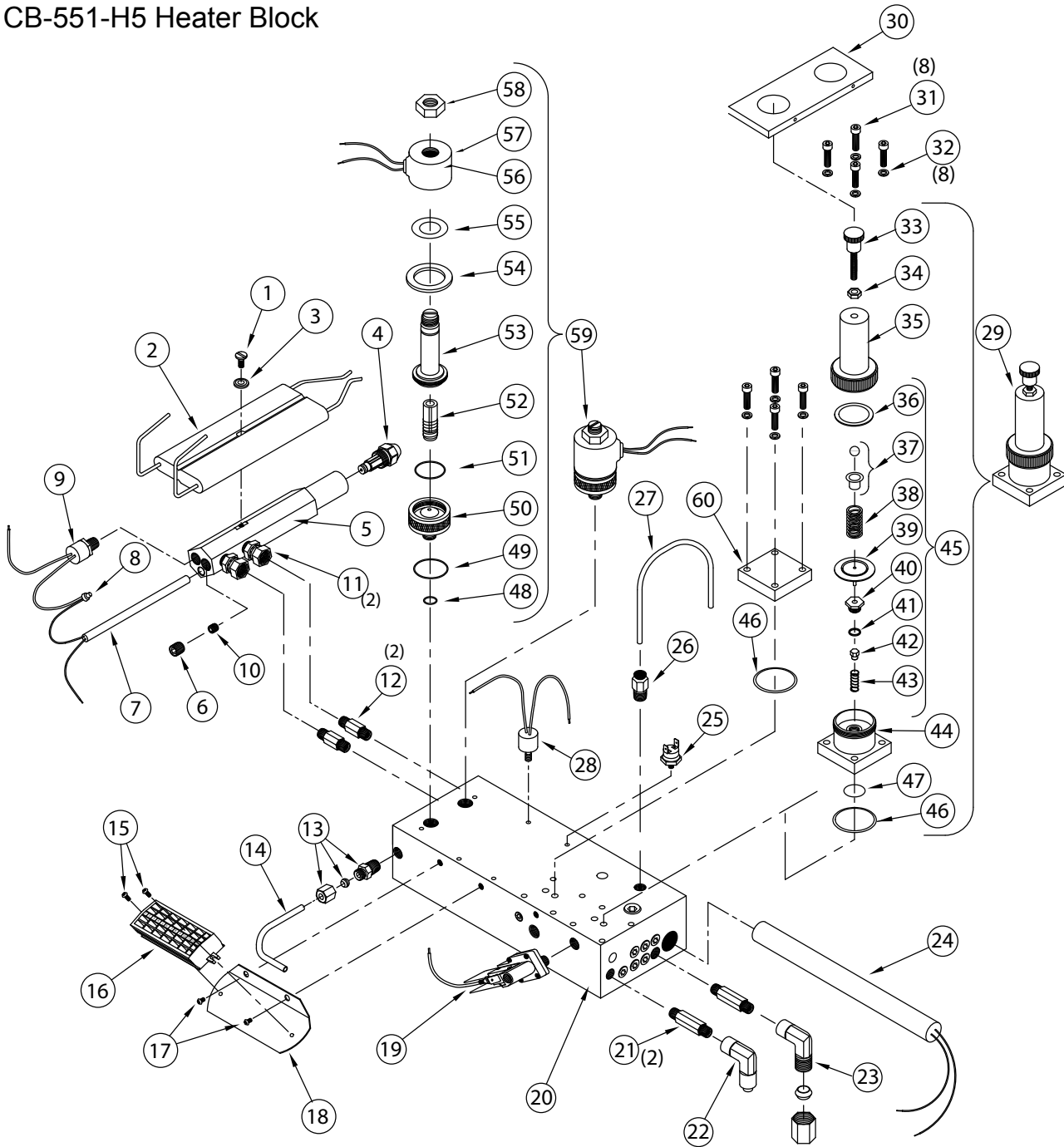

188975-A

Figure A10 - Preheater Block and Electrode Assembly Component Detail
CB-551-H5 Burner (CB-500-CTB)

Coil Tube Boiler Operator's Manual: Models CB-200-CTB, CB-350-CTB, and CB-500-CTB

<u>Item#</u>	<u>C.B. Part#</u>	<u>Qty.</u>	<u>Component Description</u>
1	34169	1	ELECTRODE SCREW - 10-32 x 3/4
2	33183	1	SINGLE PIECE ELECTRODE
3	34165	1	WASHER
4	32006	1	9 - 28 NOZZLE
5	13150	1	NOZZLE ADAPTOR
6	32007	1	PLUG - 1/8 NPT
7	33298	1	140 WATTS HEATER
8	33381	1	INSULATED CAP CRIMP CONNECTOR
9	33418	1	THERMOSTAT L-130
10	32199	1	PLUG - 1/16 NPT
11	32050	2	SWIVEL FITTING
12	32189	2	HEX NIPPLE - 1/8 NPT x 1-1/2
13	32043	1	MALE CONNECTOR - 3/16T x 1/8 NPT
14	54020	1	3/16 COPPER TUBING(OIL GAUGE LINE)
15	32201	2	MACH. SCREW PHILLIPS HD. 6-32 x 3/8 Z
16	33247	1	TERMINAL BLOCK
17	34036	4	MACH. SCREW PHILLIPS HD. 6-32 x 1/4 Z
18	26059	1	TERMINAL BLOCK BRACKET
19	33057	1	AIR PRESSURE SWITCH
20	26126	1	HEATER BLOCK
21	32190	2	HEX NIPPLE - 1/8 NPT x 2
22	32202	1	FEMALE ELBOW (FOR 1/4" AIR LINE)
23	32201	1	FEMALE ELBOW (FOR 3/8" OIL LINE)
24	33334	1	PRE-HEATER ELEMENT - 500 WATTS
25	33041	1	PROVING SWITCH (NORMALLY OPEN)
26	32325	1	MALE ELBOW 1/8 x 1/8 NPT (FOR AIR GAUGE LINE)
27	54020	1	3/16 COPPER TUBING(OIL GAUGE LINE)
28	33561	1	HEATER BLOCK THERMOSTAT(L160)
29	32359	1	REGULATOR SURFACE MOUNT
30	14090	1	REGULATOR LOCK PLATE
31	34148	8	REGULATOR MOUNTING SCREW
32	34114	8	LOCK WASHER #8 Z
33	34147	2	REGULATOR THREADED STEM
34	34022	2	HEX NUT - 10-32 Z
35	32306	2	BONNET
36	32226	2	DIAPHRAM RING
37	32364	2	CAP AND BALL ASSEMBLY
38	32227	2	COMPRESSION SPRING
39	32360	2	DIAPHRAM
40	32361	2	BRASS POPPET SEAT
41	32223	2	POPPET 'O' RING
42	32222	2	POPPET VALVE
43	32221	2	POPPET SPRING
44	32362	2	BASE
45	13142	2	REGULATOR KIT COMPONENTS
46	32308	2	REGULATOR OUTER "O" RING
47	32309	2	REGULATOR INNER "O" RING
48	33311	2	SOLENOID INNER "O" RING
49	33312	2	SOLENOID OUTER "O" RING
50	33313	2	MANIFOLD MOUNT SOLENOID BODY
51	33314	2	BODY "O" RING
52	33315	2	PLUNGER ASSEMBLY
53	33316	2	PLUNGER GUIDE ASSEMBLY
54	33317	2	FLUX PLATE
55	33318	2	WASHER SEAL
56	33319	2	COIL
57	33320	2	COIL HOUSING
58	33321	2	NUT
59	32322	2	AIR/OIL SOLENOID ASSEMBLY
60*	26107	1	REG. SQUARE CAP*

*NOTE: When the CTB is used with a metering pump, the oil regulator must be removed from the burner and replaced with the square cap.

Burner Components (continued)

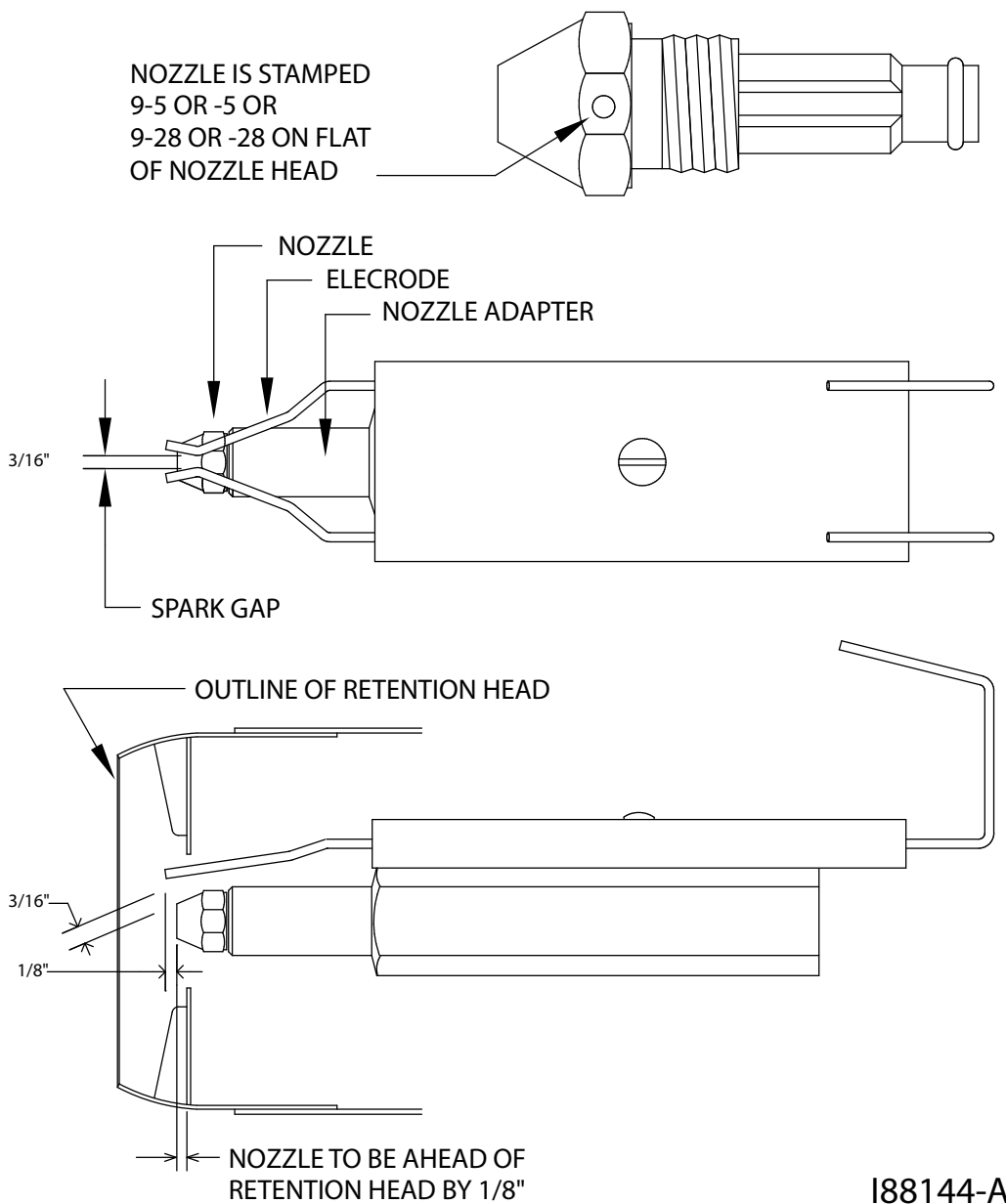

ATTENTION: Make sure the electrodes are adjusted to the specifications in these diagrams. Correct clearances must be maintained to avoid stray arcing. The minimum clearance to any ground source is 3/16". Stray arcing results in a weak spark, late burner ignition, and transformer failure.

NOTE: Clean Burn recommends the use of a special tool (CB Part# 70306) to set the retention head.

The burner electrodes should be replaced annually to maintain proper burner performance.

- Install the electrodes according to the setting and specifications in these diagrams.
- Use the shank of a 1/8" drill bit as a feeler gauge to set the spark gap at 1/8".

Figure A11 - Burner Electrode Specifications

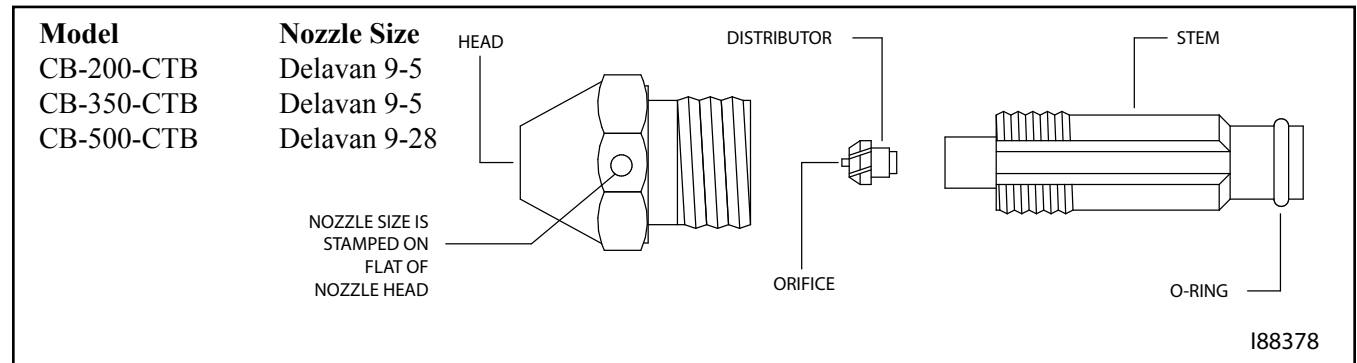
Burner Components (continued)**Removing the Nozzle for Cleaning:**

NOTE: Due to swivel fittings on the air and oil lines, it is not necessary to disconnect these lines when swinging the burner open.

1. Remove the lock-down nut on the mounting flange bolt.
2. Disconnect the burner power cable.
3. Carefully swing the burner open to its maintenance position.
4. Remove the nozzle from the nozzle adapter with a 5/8" socket.

Cleaning the Nozzle:

1. Unscrew the stem from the nozzle head.
2. Spray WD-40 or equivalent through the orifice to thoroughly remove any blockage.
CAUTION: DO NOT damage or deform the nozzle orifice; DO NOT use a torch tip cleaner or other inappropriate device to clean the orifice. If the blockage is a "tarry" material or a hard, black material, call your Clean Burn dealer for service.
3. Flush all components with WD-40 to remove oil residues.
4. Reassemble the nozzle components. When tightening the stem, just barely "snug" it down. DO NOT overtighten.
5. Check the O-ring on the nozzle stem. Replace the O-ring if it is in the least bit cut or deformed.
6. Lubricate the O-ring on the nozzle stem with a couple of drops of new motor oil, then re-install the nozzle.
7. Check the electrodes for proper gap and clearances.
8. Re-install the burner and adjust for optimal performance as necessary.

NOTE: If the nozzle plugs within a few days after cleaning, call your Clean Burn Dealer for service.

Figure A12 - Cleaning the Nozzle

CB-200-CTB

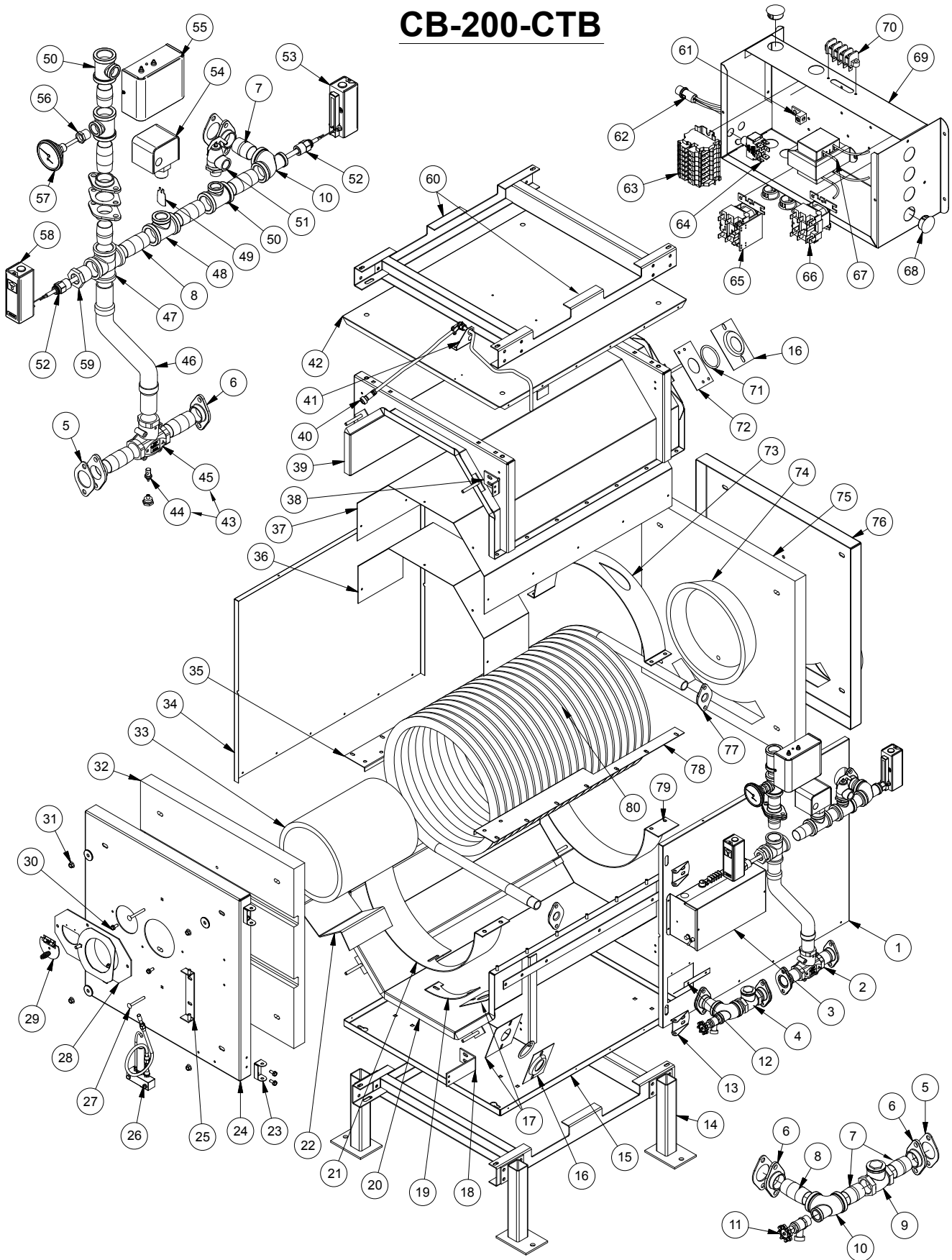

I88961-B

Coil Tube Boiler Operator's Manual: Models CB-200-CTB, CB-350-CTB, and CB-500-CTB

<u>Item#</u>	<u>Part#</u>	<u>Component Description</u>	<u>Item#</u>	<u>Part#</u>	<u>Component Description</u>
1.	27139	JACKET RH SIDE 200	•	11420	BURNER CB-525-S2 ASSEMBLY
2.	70470	MIXING VALVE 140F & FLEX PIPE KIT 200-CTB	•	11550	BOILER 200 CTB CABINET A
3.	12240	CONTROL BOX 120 V A	•	14301	PUMP METERING CB 200 CTB A
4.	14298	PIPE & CHECK VALVE 1 1/4 A	•	14302	BOLT HOLE FIBERGLASS TAPE A
5.	35053	GASKET FLANGE	•	14304	ACCESSORIES 200 CTB GP
6.	35079	FLANGE 1-1/4 NPT; BLACK	•	70427	DUCT CAP ROUND 8" - 24 GA.
7.	35052	NIPPLE 1 1/4 X 2 BLK	•	31170	DAMPER 8"
8.	35118	NIPPLE 1 1/4 X 3 BLK	•	31217	INSULATION STRIP 200 TOP
9.	35115	SWING CHECK VALVE 1 1/4 NPT	•	31218	INSULATION STRIP 200 BOT FRT
10.	35051	TEE 1 1/4 X 3/4 X 1 1/4 BLK	•	31219	INSULATION STRIP 200 BOT CENTR
11.	35065	BOILER DRAIN 3/4 NPT	•	31220	INSULATION STRIP 200 BOT REAR
12.	27148	SHIELD RET TUBE	•	34162	STOVE CEMENT - HIGH TEMP
13.	21057	HINGE BRACKET	•	42027	LABEL - WARNING - BURN/VOLTAGE
14.	90200	BOILER STAND 200 CTB (optional)	•	42030	LABEL - VOLTAGE WARNING
15.	27136	BASE 200 CTB	•	42216	LABEL - LOGO - SMALL
16.	27189	SEAL PLATE STAMPED 200	•	42217	LABEL - AIR OIL
17.	27144	SEAL PLATE FRONT OUTER	•	42231	LABEL - PRIME PUMP/RUN BURNER
18.	27147	BRACKET HINGE 200 CTB	•	42261	LABEL - THRMOSTAT/BURNER
19.	27146	FILLER FRONT TUBE	•	42421	LABEL - BOILER WARNING
20.	11537	BASE 200 CTB WA	•	44052	SCHEM CB 350 CTB (Wiring Diagram)
21.	27133	RING BURNER END	•	42464	LABEL UL DATA CB 200 CTB
22.	27155	STAND REFRACY CYL 200 CTB	•	43146	OPERATORS MANUAL CB 200/350/500 CTB
23.	21056	HINGE BRACKET	•	54013	ROPE-FIBERGLASS HD 250 W/ADH
24.	11540	DOOR 200 CTB WA	•	54104	HYDRAULIC / PNEUMATIC SEALANT
25.	11582	HINGE BRKT 3DEG BURNER WA	•	14302	FIBERGLASS BOLT HOLE TYPE 4 PER
26.	14061	HOOK-UP KIT - 200,350,2800			
27.	34120	5/16-18 X 2 3/4 CARR BOLT S.S.			
28.	11583	BURNER MOUNT 3 DEG WA			
29.	11325	INSPECTION DOOR A			
30.	34118	5/16-18 X 3/4 HEX HEAD TAP SCREW			
31.	34009	3/8-16 HEX SERR FLANGE NUT PLT			
32.	31216	INSULATION 200 FRONT DOOR			
33.	21120	REFRACTORY CYL 10 X 14			
34.	27138	JACKET LH SIDE 200			
35.	27131	BAFFLE LH 200			
36.	27150	LINER PROTECTOR			
37.	27149	LINER TOP CRADLE			
38.	27123	BRACKET 350 HINGE			
39.	11538	CRADLE TOP WA			
40.	33508	CORD 43" CONN PLUG			
41.	27158	BRACKET BURNER CORD			
42.	27140	JACKET TOP 200			
43.	14335	MIXING VALVE VTC511 & T-STAT 140F A.			
44.	35138	THERMOSTAT 160F/60C FOR VTC511			
45.	35139	THERMOSTATIC BYPASS VALVE VTC511 1-1/4"			
46.	35147	METAL FLEX HOSE 1 1/4" - 16"			
47.	35141	CROSS 1 1/4 NPT BLK			
48.	35119	1 1/4 X 1 1/4 X 1 TEE BLK			
49.	35124	PADDLE TACO FLOW SW			
50.	35066	TEE 1 1/4 X 1 1/4 X 3/4 BLK			
51.	35048	RELIEF VALVE 3/4 M			
52.	35049	WELL 3/4 NPT X 1 1/2 EXT (INS)			
53.	28149	AQUASTAT 100-240F HIGH LIMIT			
54.	35123	FLOW SWITCH; TACO			
55.	35110	LOW WATER CUT-OFF CONTROL UNIT			
56.	35057	BUSHING 3/4 X 1/2 BLK			
57.	33330	GAUGE BOILER, TEMP-PRESSURE			
58.	28150	AQUASTAT 100-200F OPERATING			
59.	35146	BUSHING 1 1/4" - 3/4" BLK			
60.	11549	BOILER STACK ADAPTOR 200CTB (optional)			
61.	33145	SCREW LUG			
62.	33168	AMBER LIGHT			
63.	33486	TERMINAL BLK A; DIN-RAIL SCREW			
64.	33286	SWITCH DPDT ON-ON			
65.	33352	RELAY DELAY			
66.	33328	RELAY DPDT			
67.	33327	TRANSFORMER 24-120V			
68.	33131	KNOCK-OUT SEAL/PLUG			
69.	27109	BOX JUNCTION A			
70.	33331	TERMINAL BLOCK (4 POST) CTB			
71.	54013	ROPE-FIBERGLASS HD 250 W/ADH			
72.	27143	SEAL PLATE REAR OUTER			
73.	27134	RING TOP STACK END			
74.	31264	ENERGY RETENTION DISC, 2-BOLT (W/HDWR)			
	11154	TARGET (REFRAC) DISC ASSY			
75.	31215	INSULATION 200 REAR PANEL			
76.	11539	PANEL REAR 200 CTB WA			
77.	35116	FLANGE 1 NPT			
78.	27132	BAFFLE RH 200			
79.	27129	RING BOTTOM STACK END			
80.	27803	COIL 1" TUBE 22.5 T 200CTB			

CB-350-CTB

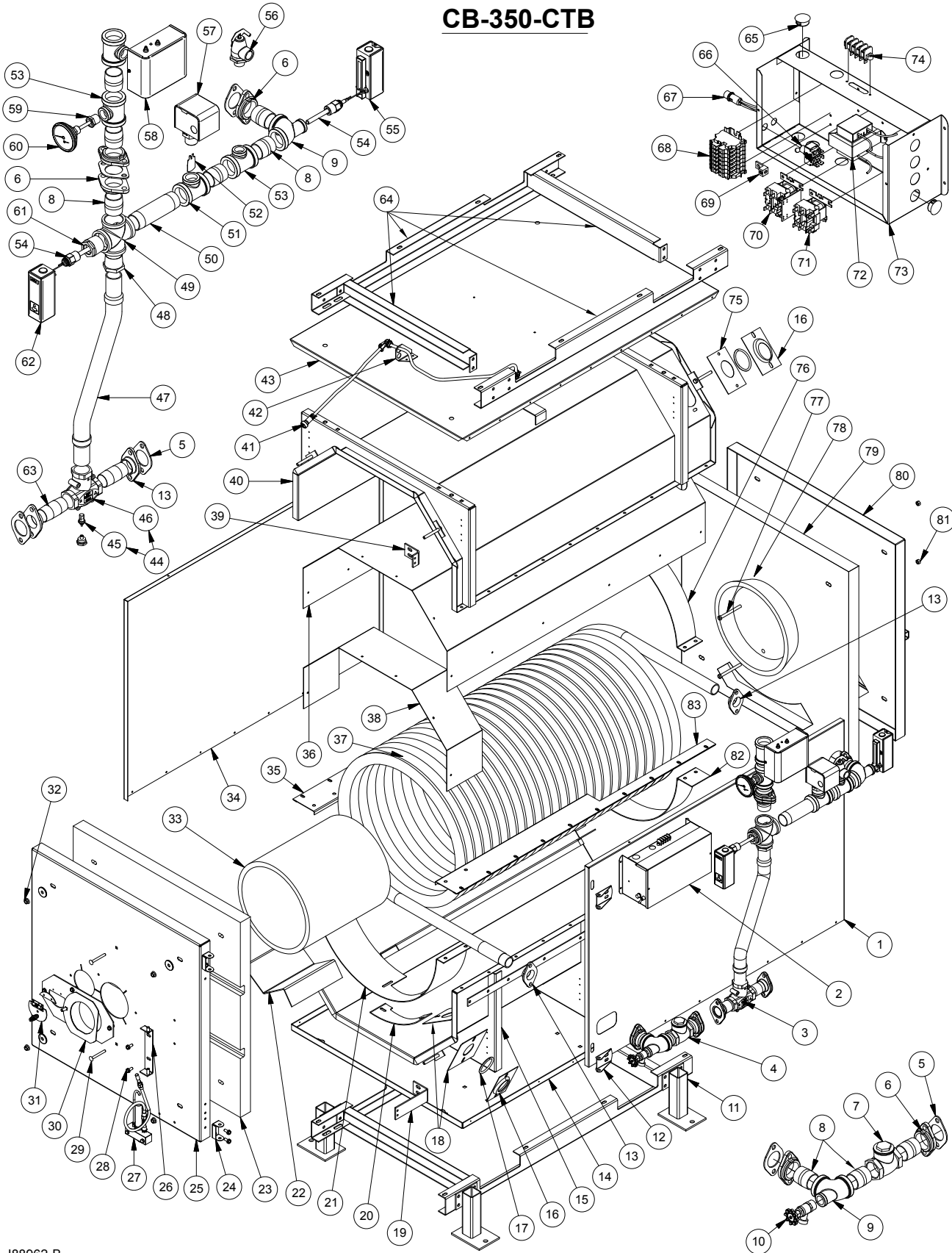

188962-B

Coil Tube Boiler Operator's Manual: Models CB-200-CTB, CB-350-CTB, and CB-500-CTB

<u>Item#</u>	<u>Part#</u>	<u>Component Description</u>	<u>Item#</u>	<u>Part#</u>	<u>Component Description</u>
1.	27093	JACKET R.H. SIDE	•	11369	CB 551 H3 BURNER A
2.	12240	CONTROL BOX 120 V A	•	11412	DOOR 350 A.
3.	70471	MIXING VALVE 140F & FLEX PIPE KIT 350-CTB	•	14201	ACCESSORIES 350 GP
4.	14293	CHECK AND DRAIN 350 PIPE A	•	28148	CTB 350 CABINET ASSEMBLY
5.	35053	GASKET FLANGE	•	70427	DUCT CAP ROUND 8" - 24 GA.
6.	35061	FLANGE 1 1/2 NPT, BLACK	•	31242	INSULATION 18.38 X 55 1/2 CTR FRONT
7.	35081	SWING CHECK 1 1/2	•	31163	INSULATION STRIP 3.06 X 55.50 TOP FRONT
8.	35069	NIPPLE 1 1/2 X 2 BLK	•	31164	INSULATION TOP 48 X 51
9.	35082	TEE 1 1/2 X 3/4 X 1 1/2 BLK	•	31168	INSULATION STRIP 21 5/8 X 55 1/2 CTR REAR
10.	35065	BOILER DRAIN 3/4 NPT	•	31169	INSULATION STRIP 5 5/16 X 55 1/2 BOT REAR
11.	90188	BOILER STAND 350 (option only)	•	31170	DAMPER 8"
12.	21057	HINGE BRACKET	•	31241	INSULATION STRIP 7.63 x 55.5 BOT FRT
13.	35079	FLANGE 1-1/4 NPT; BLACK	•	34162	STOVE CEMENT - HIGH TEMP
14.	27084	BASE CTB	•	42027	LABEL - WARNING - BURN/VOLTAGE
15.	11373	BASE CTB WA	•	42030	LABEL - VOLTAGE WARNING
16.	27186	SEAL PLATE STAMPED 350	•	42216	LABEL - LOGO - SMALL
17.	54013	ROPE-FIBERGLASS HD 250 W/ADH	•	42217	LABEL - AIR OIL
18.	27188	SEAL PLATE FLAT FRONT 350	•	42231	LABEL - PRIME PUMP/RUN BURNER
19.	27193	BRACKET HINGE 500	•	42286	LABEL - IDENT CB-350 CTB
20.	27191	FILLER FRONT TUBE 350 CTB	•	42261	LABEL - THRMOSTAT/BURNER
21.	27086	RING BURNER END	•	42292	LABEL - CTB WIRING CTB-200/350/500
22.	27190	STAND REFRACTORY 1 Pc 350	•	42366	LABEL - TANK WARNING
23.	31176	INSULATION 350 DOOR	•	42367	LABEL - FURNACE WARNING
24.	21056	HINGE BRACKET	•	42421	LABEL - BOILER WARNING
25.	11405	DOOR WA	•	43146	OPERATORS MANUAL CB 200/350/500 CTB
26.	11582	HINGE BRKT 3DEG BURNER WA	•	44052	SCHEM CB 350 CTB
27.	14061	HOOK-UP KIT - 200,350,2800	•	54104	HYDRAULIC / PNEUMATIOC SEALANT
28.	34118	5/16 - 18 X 3/4 HEX HEAD TAP SCREW	•	54013	ROPE FG HD 250 W/ADH 8"
29.	34120	5/16-18 X 2 3/4 CARR BOLT S.S.	•	14184	FIBERGLASS BOH HOLE TAPE 4 PER
30.	11583	BURNER MOUNT 3 DEG WA			
31.	11325	INSPECTION DOOR A			
32.	34009	3/8-16 HEX SERR FLANGE NUT PLT			
33.	21140	REFRACTORY CYL (1 Pc. 350)			
34.	27050	JACKET L.H. SIDE			
35.	27087	BAFFLE RH			
36.	27090	LINER COMBUSTION CHAMBER			
37.	27802	COIL 1 1/4 PIPE 26.5T			
38.	27115	LINER PROTECTOR			
39.	27123	BRACKET 350 HINGE			
40.	11374	COVER TOP WA			
41.	33546	CONN CORD 4-WIRE 51"			
42.	27158	BRACKET BURNER CORD			
43.	27095	JACKET TOP CTB			
44.	14335	MIXING VALVE VTC511 & T-STAT 140F A.			
45.	35138	THERMOSTAT 160F/60C FOR VTC511			
46.	35139	THERMOSTATIC BYPASS VALVE VTC511 1-1/4"			
47.	35148	METAL FLEX HOSE 1 1/4" - 24"			
48.	35149	BUSHING 1 1/2" - 1 1/4" BLK			
49.	35140	CROSS 1 1/2 NPT BLK			
50.	35068	NIPPLE 1 1/2 X 6 BLK			
51.	35084	TEE 1 1/2 X 1 1/2 X 1 BLK			
52.	35124	PADDLE TACO FLOW SW			
53.	35083	TEE 1 1/2 X 1 1/2 X 3/4 BLACK			
54.	35049	WELL 3/4 NPT X 1 1/2 EXT (INS)			
55.	28149	AQUASTAT 100-240F HIGH LIMIT			
56.	35135	RELIEF VALVEI ; 30 PSI; (for CB-350-CTB)			
57.	35123	FLOW SWITCH; TACO			
58.	35110	LOW WATER CUT-OFF CONTROL UNIT			
59.	35057	BUSHING 3/4 X 1/2 BLK			
60.	33330	GAUGE BOILER, TEMP-PRESSURE			
61.	35145	BUSHING 1 1/2" - 3/4" BLK			
62.	28150	AQUASTAT 100-200F OPERATING			
63.	35118	NIPPLE 1 1/4 X 3 BLK			
64.	90187	BOILER STACKING ADAPTOR 350 (option only)			
65.	33131	KNOCK-OUT SEAL/PLUG			
66.	33286	SWITCH DPDT ON-ON			
67.	33168	AMBER LIGHT			
68.	33486	TERMINAL BLK A; DIN-RAIL SCREW			
69.	33145	SCREW LUG			
70.	33352	RELAY DELAY			
71.	33328	RELAY DPDT			
72.	33327	TRANSFORMER 24-120V			
73.	27109	BOX JUNCTION A			
74.	33331	TERMINAL BLOCK (4 POST) CTB			
75.	27187	SEAL PLATE FLAT REAR 350			
76.	27089	RING TOP STACK END			
77.	34150	3/8-16 X 4 HHCS 18-8			
78.	31264	ENERGY RETENTION DISC, 2-BOLT (W/HDWR)			
	11154	TARGET (REFRAC) DISC ASSY			
79.	31166	INSULATION PANEL			
80.	11380	PANEL REAR 350 WA			
81.	34067	3/8-16 FIN HEX NUT 18-8 S.S.			
82.	27037	RING STACK END			
83.	27088	BAFFLE LH			

CB-500-CTB

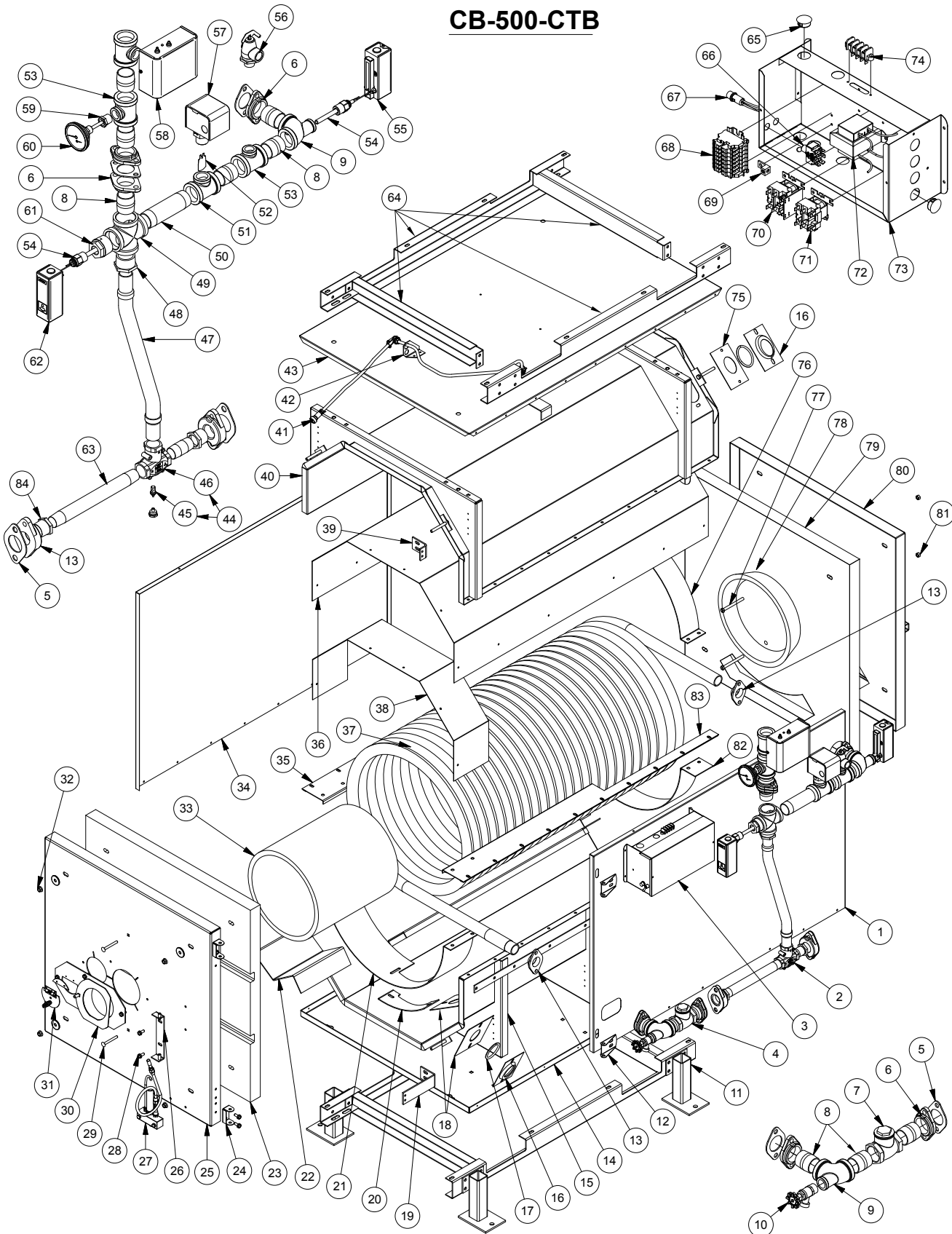

188997-C

Coil Tube Boiler Operator's Manual: Models CB-200-CTB, CB-350-CTB, and CB-500-CTB

<u>Item#</u>	<u>Part#</u>	<u>Component Description</u>	<u>Item#</u>	<u>Part#</u>	<u>Component Description</u>
1.	27172	JACKET RH SIDE 500	•	11565	CTB 500 BOILER CABINET ASSMBLY
2.	70472	MIXING VALVE 140F & FLEX PIPE KIT 500-CTB	•	11567	DOOR FRONT 500 A
3.	12240	CONTROL BOX 120 V A	•	11580	CB-551-H5 BURNER A
4.	14314	CHECK AND DRAIN 500 PIPE A	•	14317	ACCESSORIES 500 CTB GP
5.	35125	GASKET FLANGE 2"	•	70428	DUCT CAP ROUND 10" - 24 GA.
6.	35120	FLANGE 500 2" NPT	•	31197	DAMPER 9" ASSEMBLY
7.	35126	CHECK VALVE 2" NPT SWING; Type WCW	•	31245	INSUL. 62.0 X 48.0 BLANKET TOP
8.	35128	NIPPLE 2 X 2 1/2" SCH 40 BLK	•	31246	INSUL. 14.31X 62.0 BLANKET TOP FRT
9.	35133	TEE 2 X 3/4 X 2 NPT BLK	•	31247	INSUL. 24.0 X 66.0 BLANKET BOT CTR
10.	35065	BOILER DRAIN 3/4 NPT	•	31248	INSUL. 7.50 X 66.0 BLANKET BOT FRT + REAR
11.	90206	BOILER STAND 500 A (optional)	•	34162	STOVE CEMENT - HIGH TEMP
12.	21057	HINGE BRACKET	•	35137	NIPPLE 3/4 X 2 NPT SCH40 BRASS
13.	35121	FLANGE 500 1 1/2" NPT	•	42027	LABEL - WARNING - BURN/VOLTAGE
14.	27170	BASE 500	•	42030	LABEL - VOLTAGE WARNING
15.	11572	BASE 500 CTB WA	•	42217	LABEL - AIR OIL
16.	27178	SEAL PLATE STAMPED 500	•	42231	LABEL - PRIME PUMP/RUN BURNER
17.	54013	ROPE-FIBERGLASS HD 250 W/ADH	•	42261	LABEL - THRMOSTAT/BURNER
18.	27177	SEAL PLATE FLAT FRONT	•	42292	LABEL - CTB WIRING CTB-200/350/500
19.	11581	HINGE BRKT DOOR LOWER WA	•	42366	LABEL - TANK WARNING
20.	27179	FILLER PLATE 500	•	42367	LABEL - FURNACE WARNING
21.	27166	RING BURNER END 500	•	42457	LABEL-MADE IN USA/PAT PENDING
22.	27200	STAND REFRACTORY CYL 500 CTB	•	42421	LABEL - BOILER WARNING
23.	31240	INSULATION FRONT DOOR 500	•	42493	LABEL IDENT CB 500 CTB
24.	21056	HINGE BRACKET	•	42497	LABEL - LOGO - LARGE; 8" x 20"
25.	11564	DOOR FRONT 500 WA	•	43146	OPERATORS MANUAL CTB
26.	11582	HINGE BRKT 3DEG BURNER WA	•	44052	SCHEM CB 350 CTB (Wi ring Diagram)
27.	14103	CB-5000 HOOK-UP A	•	54104	HYDRAULIC / PNEUMATIC SEALANT
28.	34118	5/16 - 18 X 3/4 HEX HEAD TAP SCREW	•	70469	500 CTB BARE CABINET
29.	34120	5/16-18 X 2 3/4 CARR BOLT S.S.	•	70477	SEAL KIT FOR TACO 2400-50/2 CIRCULATOR
30.	11583	BURNER MOUNT 3 DEG WA	•	54013	ROPE FIG HD 250 W/ADH 8'
31.	11325	INSPECTION DOOR A	•	14346	FIBERGLASS BOLT HOLE TAPE 4 PER
32.	34009	3/8-16 HEX SERR FLANGE NUT PLT			
33.	21174	REFRACTORY CYL 12.63 X 20			
34.	27171	JACKET LH SIDE 500			
35.	27163	BAFFLE LH 500			
36.	27181	LINER COMBR CHM TOP 500			
37.	27804	COIL 1.50 TUBE 28.5 T 500CTB			
38.	27180	LINER PROTECTOR 500			
39.	11596	BRACKET 500 UPPER HINGE WA			
40.	11562	COVER TOP 500 CTB WA			
41.	33546	CONN CORD 4-WIRE 51"			
42.	27158	BRACKET BURNER CORD			
43.	27173	JACKET TOP 500			
44.	14335	MIXING VALVE VTC511 & T-STAT 140F A.			
45.	35138	THERMOSTAT 160F/60C FOR VTC511			
46.	35139	THERMOSTATIC BYPASS VALVE VTC511 1-1/4"			
47.	35148	METAL FLEX HOSE 1 1/4" - 24"			
48.	35143	BUSHING 2" - 1 1/4" BLK			
49.	35142	CROSS 2"NPT BLK			
50.	35127	NIPPLE 2 X 6 SCH 40 BLK			
51.	35132	TEE 2 X 2 X 1 NPT BLK			
52.	35124	PADDLE TACO FLOW SW			
53.	35131	TEE 2 X 2 X 3/4 NPT BLK			
54.	35049	WELL 3/4 NPT X 1 1/2 EXT (INS)			
55.	28149	AQUASTAT 100-240F HIGH LIMIT			
56.	35136	RELIEF VALVE; 30 PSI; (for CB-500-CTB)			
57.	35123	FLOW SWITCH; TACO			
58.	35110	LOW WATER CUT-OFF CONTROL UNIT			
59.	35057	BUSHING 3/4 X 1/2 BLK			
60.	33330	GAUGE BOILER, TEMP-PRESSURE			
61.	35144	BUSHING 2" - 3/4" BLK			
62.	28150	AQUASTAT 100-200F OPERATING			
63.	35150	NIPPLE 1 1/4" - 14" BLK			
64.	11578	BOILER STACKING ADAPT 500 CTB A (optional)			
65.	33131	KNOCK-OUT SEAL/PLUG			
66.	33286	SWITCH DPDT ON-ON			
67.	33168	AMBER LIGHT			
68.	33486	TERMINAL BLK A; DIN-RAIL SCREW			
69.	33145	SCREW LUG			
70.	33352	RELAY DELAY			
71.	33328	RELAY DPDT			
72.		33327 TRANSFORMER 24-120V			
73.	27109	BOX JUNCTION A			
74.	33331	TERMINAL BLOCK (4 POST) CTB			
75.	27176	SEAL PLATE FLAT REAR			
76.	27167	RING TOP STACK END			
77.	34150	3/8-16 X 4 HHCS 18-8			
78.	31264	ENERGY RETENTION DISC, 2-BOLT (W/HDWR)			
	11154	TARGET (REFRAC) DISC ASSY			
79.	31239	INSULATION DOOR REAR 500			
80.	11563	DOOR REAR BREECH 500 CTB WA			
81.	34067	3/8-16 FIN HEX NUT 18-8 S.S.			
82.	27165	RING BOT STACK END 500			
83.	27164	BAFFLE RH 500			
84.	35149	BUSHING 1 1/4 - 1 1/2 NPT			

Metering Pump Components

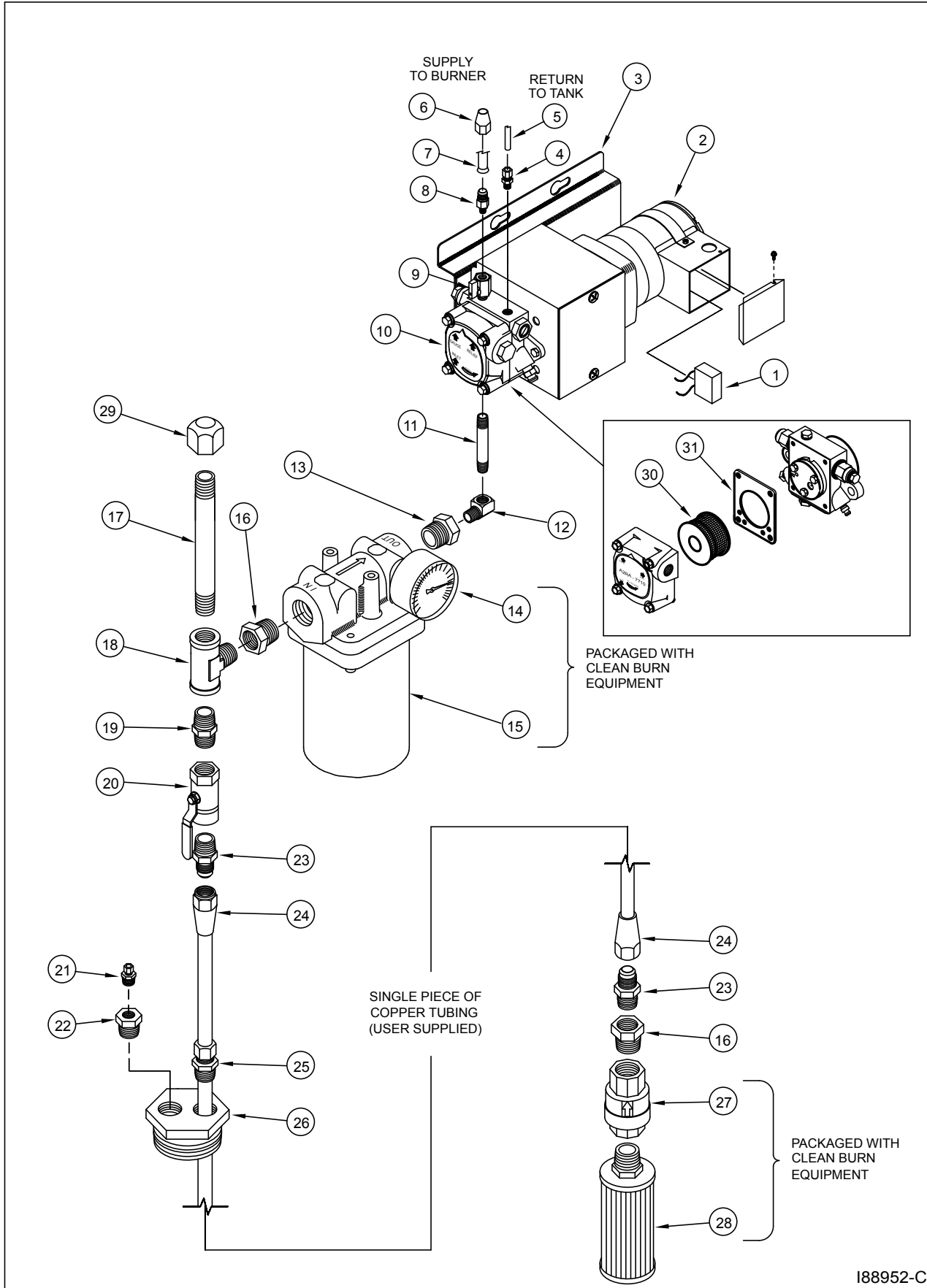

188952-C

Coil Tube Boiler Operator's Manual: Models CB-200-CTB, CB-350-CTB, and CB-500-CTB

<u>Item#</u>	<u>Part#</u>	<u>Component Description</u>	<u>Item#</u>	<u>Part#</u>	<u>Component Description</u>
1.	33363	CAPACITOR	•	13176	SUCTION FITTINGS PACKAGE
2.	33507	GEAR MOTOR CB 200 CTB			
	33295	GEAR MOTOR CB 350 CTB			
	33558	GEAR MOTOR CB 500 CTB			
3.	11322	MOUNT METER PUMP A			
4.	32037	1/8 NPT X 1/4 TUBE COMPRESSION FITTING			
5.	N/A 1/4	COPPER OR ALUMINUM TUBING			
6.	N/A 3/8	OR 1/2 TUBE FLARE NUT			
7.	N/A 3/8	OR 1/2 COPPER FOR ALUMINUM TUBING			
8.	N/A 1/8	M NPT X 3/8 OR 1/2 FLARE			
9.	32526	MINI BALL VALVE 1/8 MNPT X 1/8 FNPT			
10.	32475	PUMP-METERED OIL			
11.	32467	NIPPLE 1/4 NPT X 3 ROUND BRASS			
12.	32210	ST EL 90 1/4F-1/4M NPT			
13.	32336	BUSHING 3/4 X 1/4 BR.			
14.	32123	GAUGE (LENZ)			
15.	32127	CANISTER FILTER			
16.	32430	BUSHING 3/4" X 1/2"			
17.	32446	NIPPLE 1/2 X 5"-BRASS			
18.	32429	TEE 1/2" BRANCH			
19.	32137	EXTERNAL PIPE ADAPTER			
20.	32142	BALL VALVE 1/2 NPT			
21.	32062	MALE CONNECTOR 1/4 TUBE			
22.	32443	BUSHING 1/4 X 1/2" BRASS			
23.	32141	FLARED TUB.TO PIPE STRAIGHT			
24.	32140	LONG NUT 1/2			
25.	32139	TUBE TO PIPE MALE STRAIGHT			
26.	32442	BUSHING DUPLEX SLIP THRU			
27.	32021	CHECK VALVE			
28.	32061	CHECK VALVE SCREEN 3/4"			
29.	32445	PIPE CAP 1/2"-BRASS			
30.	32423	SCREEN PUMP (M PUMP)			
31.	32422	GASKET COVER (M PUMP)			

APPENDIX B

Wiring Diagrams

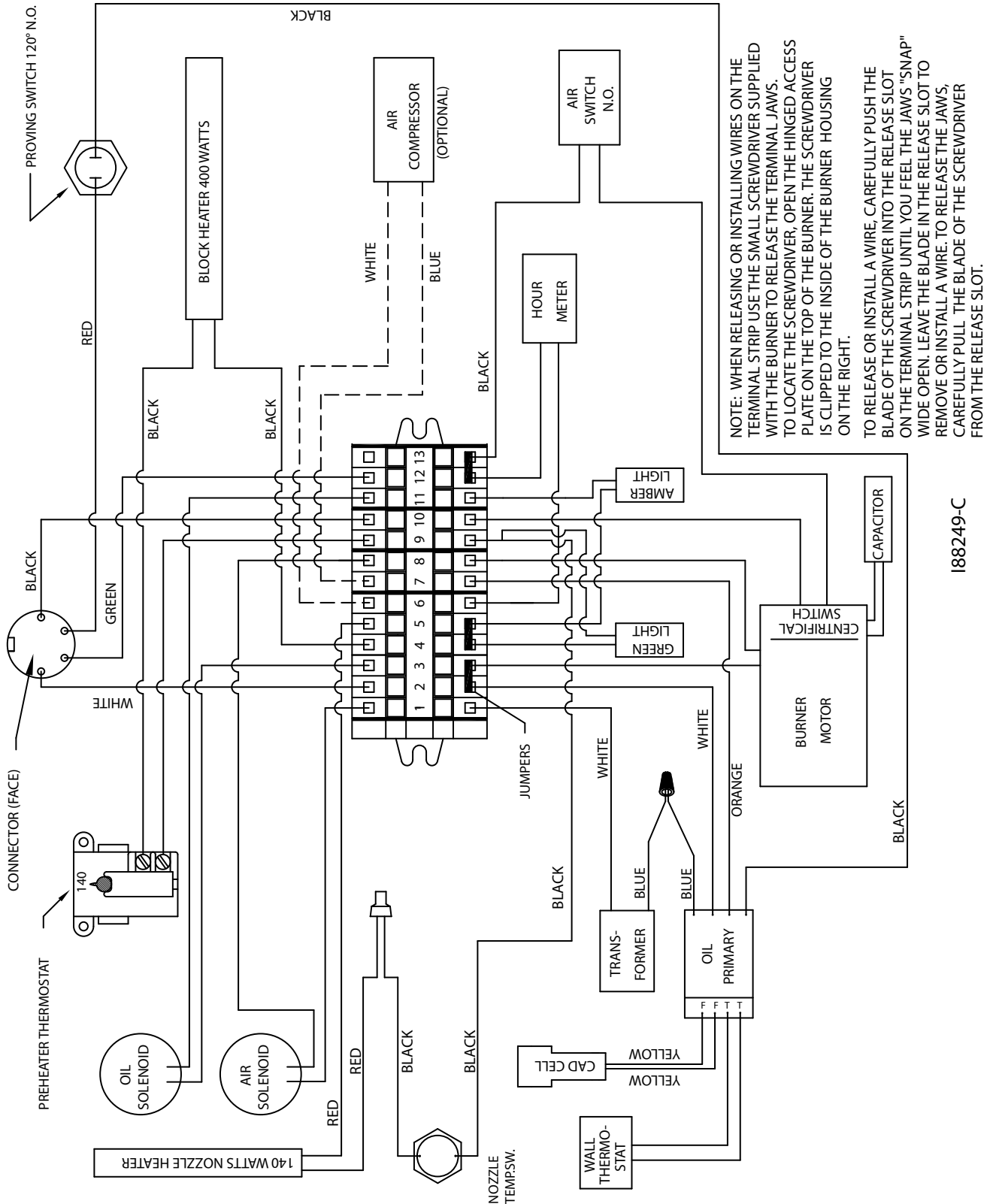

188249-C

Figure B1 -CB-525-S2 Burner Wiring Diagram (CB-200-CTB)

Wiring Diagrams (continued)

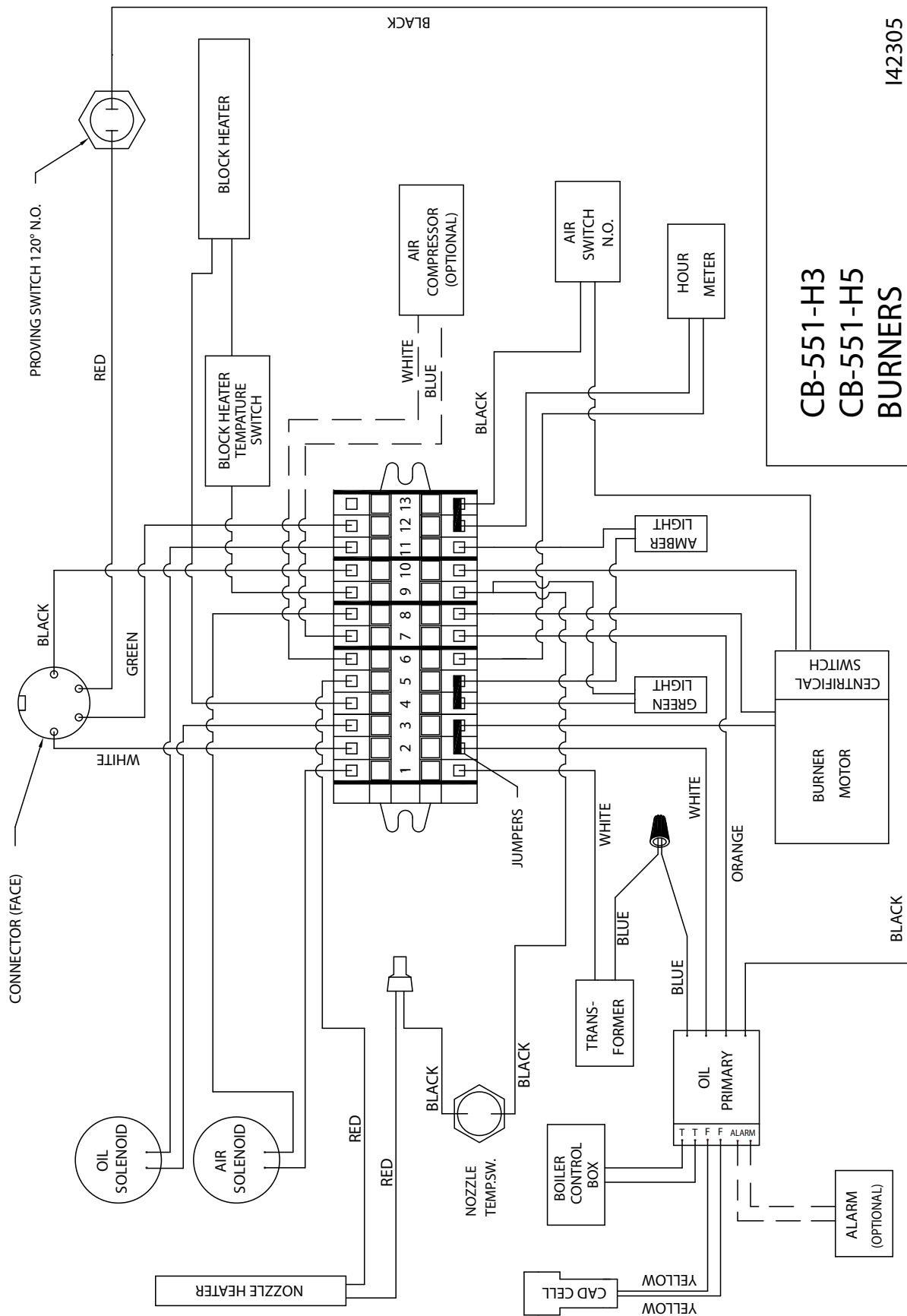

142305

CB-551-H3
CB-551-H5
BURNERS

Figure B2 - CB-551-H3 and CB551-H5 Burner Wiring Diagram (CB-350-CTB and CB-500-CTB)

Wiring Diagrams (continued)

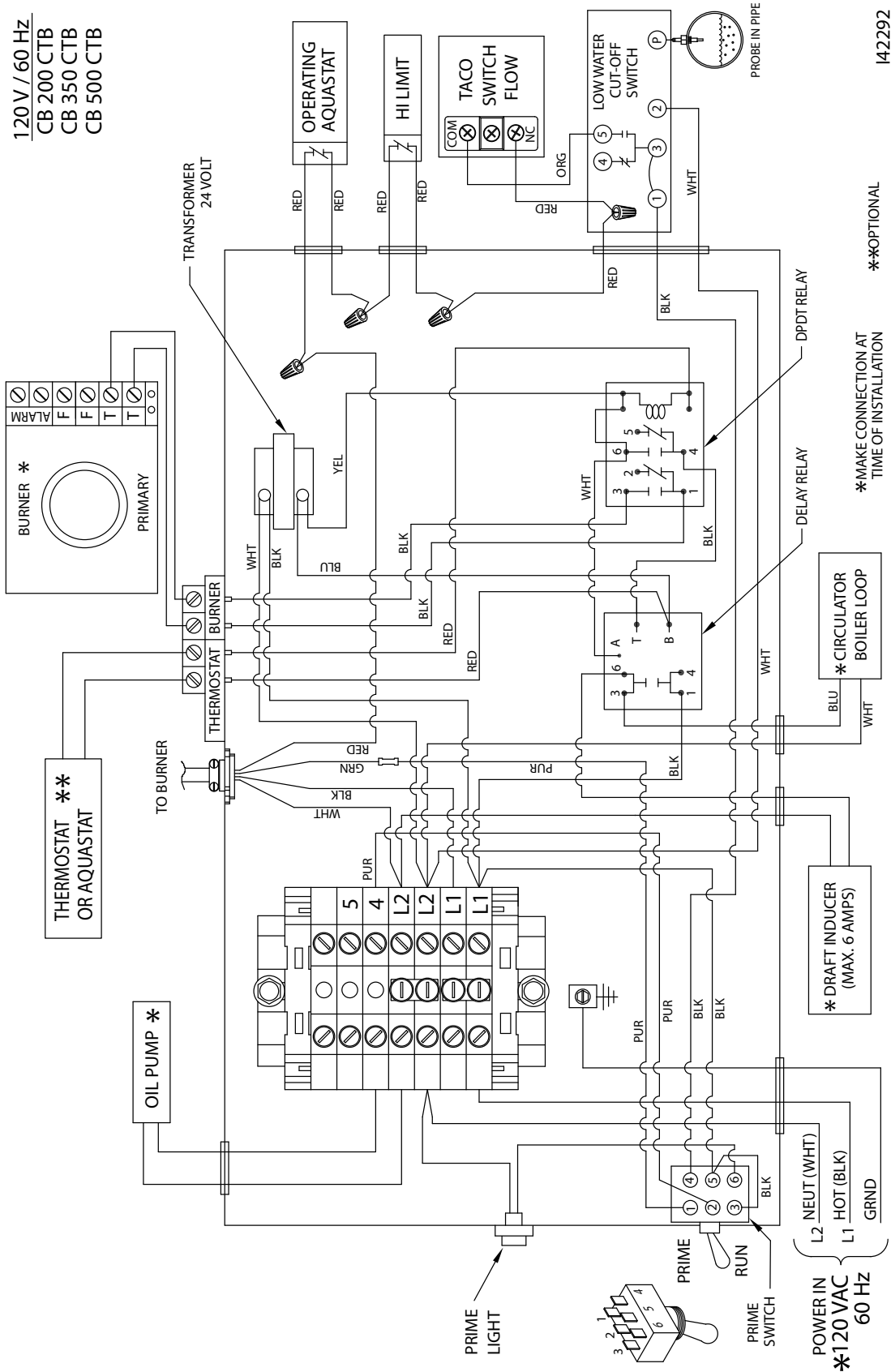

Figure B3 - Coil Tube Boiler Wiring Diagram (Control Box)

The CTB sequence of operation is summarized as follows:

- (1) A call for heat by the thermostat energizes the DPDT relay which in turn energizes the circulator delay relay and the boiler loop circulator to establish a flow of water through the coil.
- (2) The low water cut-off "proves" the water level inside the boiler and allows the flow switch to close. The power then continues from the flow switch through the high limit aquastat, through the operating aquastat, and then to the burner.
- (3) If the burner ignites within approximately 15 seconds and the cad cell sees flame, the burner will continue to operate until the call for heat is satisfied or the setting of the operating aquastat is reached.
- (4) If the thermostat is not satisfied, but the temperature setting of the operating aquastat is reached, the burner will stop until the return water drops the water temperature in the boiler (re-closing the operating aquastat and turning the burner back on).
- (5) The boiler loop circulator will operate as long as the thermostat is calling for heat.
- (6) The boiler loop circulator circuit includes a delay relay that keeps the circulator operating approximately ten minutes after the call for heat is satisfied.

NOTE 1:

TDR TIMER CONTACT CLOSSES INSTANTANEOUSLY WHEN RELAY IS ENERGIZED (TRIGGERED BY CR1) AND OPENS 10 MINUTES AFTER CR1 IS DE-ENERGIZED

NOTE 2:

DPDT TOGGLE SWITCH ON BOILER CABINET
TOGGLE DOWN: BURNER
TOGGLE UP: PRIME PUMP

NOTE 3:

CB-350-CTB and CB-500-CTB PRIMARY CONTROL IS SHOWN. CB-200-CTB PRIMARY CONTROL IS SIMILAR WITH NO ALARM.

- ⊗ - CONNECTION TO CUSTOMER POWER
- - CONNECTION AT TERMINAL BLOCK OUTSIDE BOILER CONTROL BOX

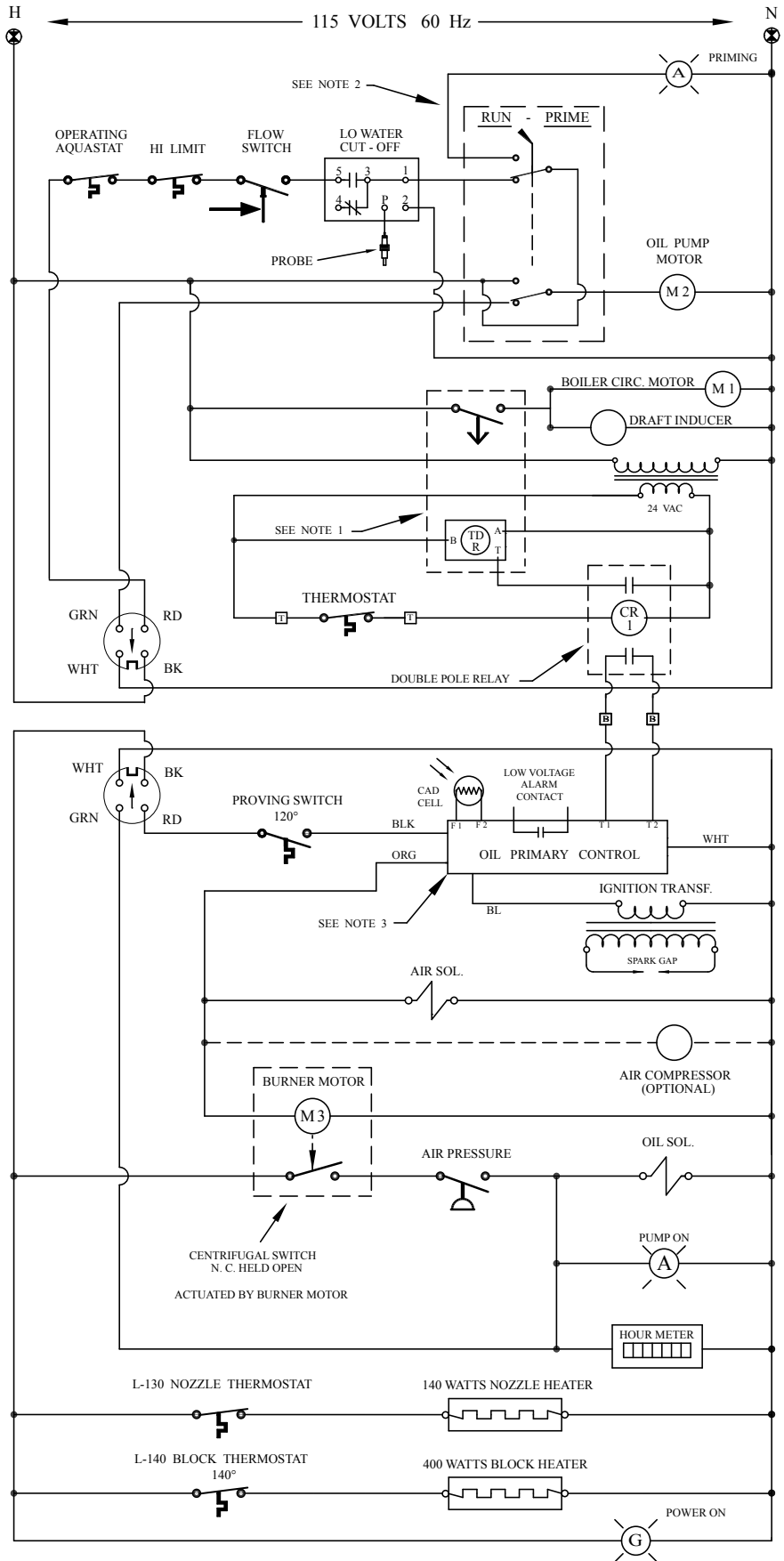

I44087

Figure B4 - Coil Tube Boiler Ladder Schematic

Wiring Diagrams (continued)

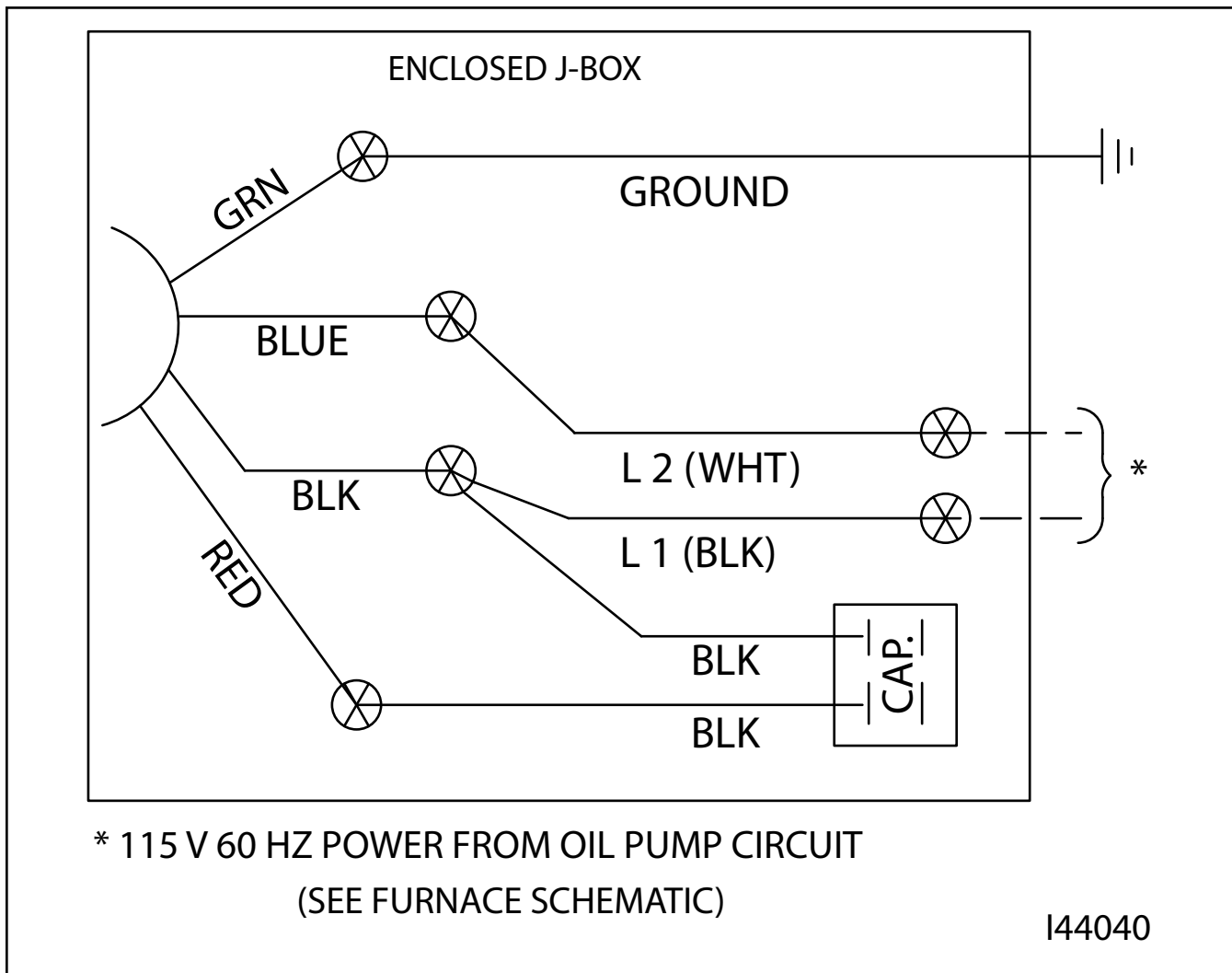

Figure B4 - Metering Pump Wiring Schematic

Understanding the Oil Primary Control (CB-200-CTB)

Model 40200 / 42230 Cad Cell Oil Primary Control Data Sheet

Model 40200/ 42230 CAD Cell Oil Primary Control Data Sheet

C77009



- Oil pump bleed assist up to 1 min.
- Thermostat/aquastat compatible
- Recycle on flame failure
- Improved SMC Technology
zero bleed voltage during standby
- Serviceman Reset Protection
Latch-up after 3 consecutive lockouts
- Works well with generators
Insensitive to frequency changes
- Diagnostic LED's Status, lockout, flame
- Flame Stabilize
- 15-second TFI/ 30-second TFI
- Increased flame accuracy

Power input (from limit circuit)	120 VAC, 60 HZ, 10 VA
Motor load	10 FLA/ 60 LRA
Ignitor load	120 VAC, 60 HZ, 500 VA
Operating temperature limits	+32°F to +140°F

Storage temperature limits	-40°F to +185°F
Thermostat anticipator current	0.1 A, AC
Cad cell resistance (with flame)	R < 1500 OHMS
Agencies	UL recognized (US & Canada)

Installing and wiring

Warning — 40200 and 42230 controls must be installed and serviced only by a qualified service technician.

- Always disconnect power source before wiring to avoid electrical shock or damage to the control. All wiring must comply with applicable codes and ordinances.
- Thermostat terminals (T–T) provide a current source. Never apply external power to these terminals under any circumstances.

Mounting

The control may be mounted on a 4" x 4" junction box in any convenient location on the burner, furnace or wall. The location must not exceed the ambient temperature limit, 140°F.

Wiring

Wiring must comply with local and national electrical codes, and with the wiring diagram.

Field checks

- Safety timing (TFI) test** — Remove one cad cell wire (F-F). Start burner. The control should lockout within the TFI time limit. Replace cad cell wire.
- Flame failure test** — Start burner. After flame is established (after TFI period), close the oil supply hand valve. This will cause a flame failure sequence as described on the reverse side of this Data sheet. The control should recycle (restart after 65 seconds).
- If control does not operate as described, check the wiring.

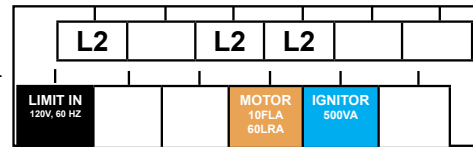

Start-up & operation

WARNING Do not start the burner if the combustion chamber contains oil or oil vapor.

NOTICE Per UL requirements, the control will not turn on if the cad cell senses flame during the self-test. If the cad cell sees light (flame) at the beginning of a cycle, the control will remain in self-test mode until the cad cell no longer senses light (flame). The amber LED will flash on momentarily every 3 to 4 seconds & green LED will be on or blinking.

Model 40200/42230 diagnostic LED's		
Ⓐ – Amber OFF	Ⓐ – Amber ON	Ⓐ – Amber FLASHING
Ⓒ – Green OFF	Ⓒ – Green ON	Ⓒ – Green FLASHING
Ⓡ – Red OFF	Ⓡ – Red ON	Ⓡ – Red FLASHING

ⒶⓇⒸ **Power ON** Open all manual oil line valves. Close the line switch.

ⒶⓇⒸ **Self-test 1** The control performs a "boot-up" test to verify internal operation each time power is applied to the black wire. The amber LED turns on and the test continues for about 5 seconds. If the test fails, the control turns the amber LED off and repeats this test sequence until successful.

ⒶⓇⒸ **Stand-by** (No call for heat) If Self-test 1 is successful, amber LED turns off and control waits for heat call.

ⒶⓇⒸ **Call for heat** Set thermostat and limit to call for heat. Thermostat circuit must be closed and power coming to black wire from limit circuit.

Self-test 2 If a failure occurs in this self-check, the control won't start and the amber LED blinks 1 second on, 4 seconds off, until serviced or the problem clears. These failures include CAD cell seeing light, internal fault, or line voltage <90V. See service section.

ⒶⓇⒸ **Burner on** After the self-test, amber LED turns off. The ignitor starts, followed 2 seconds later by the motor.

Understanding the Oil Primary Control (CB-200-CTB) Cont.

Model 40200 / 42230 Cad Cell Oil Primary Control Data Sheet

C77010

Start-up & operation continued...

Pump Prime To enter pump prime: 1. Start a CFH cycle. During Pre-ignition or Pre-Purge, press Reset until motor turns off (10 seconds), then release the button. When motor turns back on, within 5 seconds, press the Reset button until the amber LED starts to flash. You are in Pump Prime, release Reset button.

Optional Pump Prime notes: 1) If lost, press Reset for 1 second and release, then if the control is not in Pump Prime, restart the sequence. 2) If Reset is released before end of first 10 seconds, the control returns to Standby and restarts another CFH cycle. 3) If reset is not pressed the second time, a normal CFH cycle will continue. 4) If motor and igniter are on and amber LED is flashing, the control is in Pump Prime. 5) Pump Prime will exit standby if flame is detected, or 60 seconds has elapsed, or loss of TT or Limit, or Reset button is pressed.

- (A)(G)(R) TFI** The cad cell must sense flame within the TFI time limit (trial for ignition). Insufficient flame puts control into lockout.
- (A)(G)(R) Run** The burner continues firing during call for heat if the CAD cell is sensing flame. Only the green LED is on during normal running.
- (A)(G)(R) Lockout** If cad cell does not sense flame within the TFI time limit after the burner starts, **lockout** occurs. The control turns the red LED on constant, and closes the alarm contact.
- To Reset** Push in and hold reset button for 2 seconds, then release.
- (A)(G)(R) Latch-up** If the control locks out 3 times during a single call for heat, latch-up occurs. The control turns on both the amber and red LED's constant. You must use the special procedure below to reset the control after latch-up.
- WARNING** Reset after latch-up- only a qualified service technician should attempt to reset the control after latchup. The problem that caused the repeated burner lockouts must be corrected before returning the burner to normal operation.
- (A)(G)(R)** Push in and hold the reset button for 10 seconds. The amber light will begin to flash.
- (A)(G)(R)** After the LED begins flashing, continue holding the reset button for 20 seconds. The LED's will turn off. Release the reset button and the control will restart (releasing the button before the LED's turn off will cause the control to remain in latch-up).
- NOTICE** The 40200 & 42230 controls will retain lockout or latch-up if power is interrupted.
- (A)(G)(R) Flame failure** If the CAD cell loses flame signal during operation (after the TFI), the red LED flashes. **Recycle:** Control waits for 65 seconds (with red LED flashing), then begins again at Self-test 2. Red LED goes off (R).
- (A)(G)(R) NOTICE** If the green LED is blinking during a run, the flame is weak or unstable and the control may go into recycle.
- (A)(G)(R) Stand-by** Control remains in stand-by mode until limit circuit sends power to the black wire and thermostat circuit closes (call for heat).

Service & Troubleshooting

Burner (control) will not come on

(A)(G)(R) No power to control

- Check limit circuit to the control (at least 102 VAC).
- Check all electrical connections.

(A)(G)(R) Control is in lockout

- Red LED will be on. Press the reset button for 2 seconds.

(A)(G)(R) CAD cell seeing light

- Green LED on, and amber LED blinking 1 second on, 4 seconds off. Remove one yellow lead from FF terminals. If the amber LED remains flashing, the control is defective.

If the amber LED goes OFF, the control is OK, and;

- light is leaking into the burner housing, *OR*
- CAD cell is defective, *OR*
- there is a problem with the CAD cell wiring or holder.
- If appliance was recently shut down, CAD cell may see residual hot spots in chamber.

To troubleshoot:

- Attach multimeter to monitor CAD cell resistance. Dark resistance should be over 50K ohms, and room light resistance (control flipped open) should be at most 10K ohms. Replace cell if necessary, or reinstall and close the burner housing.
- Check for stray light by measuring the CAD cell resistance looking into the inactive combustion chamber. It should read at least 50 KOHMS.

(A)(G)(R) Other no start problems

If the CAD cell is OK, and the amber LED still blinks 1 second on, 4 seconds off, the other possible failures include:

- Line voltage <90 VAC (amber LED flashes uniquely; 1 second on, 1/2 second off, 1 second on, 3 seconds off, then repeats). Check line voltage.

- Internal fault: CAD cell, and line voltage OK, the issue may be an internal fault. Replace the control.

Repeated flame failures ((A)(G)(R) flashing red LED)

Check for:

- CAD cell is defective. Replace.
- Air leaking into oil line causing flame out- check oil line connections and filter gasket.
- Defective nozzle causing flame to be erratic- change nozzle.
- Excessive airflow or draft causing flame to leave burner head- check for proper air band setting and draft.
- Excessive back pressure causing flame to be erratic- check appliance and flue for sooting/plugging.

Control locks out at end of TFI ((A)(G)(R) red LED on)

Check for:

- No oil to burner- check oil supply, filters, lines.
- Shorted electrodes- inspect for cracked porcelain and replace as needed.
- Poor spark- check electrode spacing and condition per burner manual. Replace or realign if necessary.
- Nozzle clogged- replace nozzle.
- Airflow too high- check air band setting.
- Ignitor module defective- replace if no spark.
- CAD cell defective
- Oil valve (if used) stuck in closed position.
- Check wiring connections.

Understanding the Oil Primary Control (CB-350-CTB & CB-500-CTB)

Model 50200 Cad Cell Oil Primary Control Data Sheet

C77011

Model 50200 CAD Cell Oil Primary Control Data Sheet



- **Interrupted duty ignition**
- **Recycle on flame failure**
- **Serviceman Reset Protection**
Latch-up after 3 consecutive lockouts
- **Diagnostic LED's** Status, lockout, flame
- **15-second TFI/30-second TFI**
- **Thermostat/aquastat compatible**
- **SMC Technology**
- **Pump Prime**
- **Alarm contacts**

Power input (from limit circuit)	120 VAC, 60 HZ, 9VA
Motor load	10 FLA/ 60 LRA
Ignitor load	120 VAC, 60 HZ, 500 VA
Alarm contacts	24 V, AC/DC, 2A
Operating temperature limits	+32°F to +140°F

Storage temperature limits	-40°F to +185°F
Thermostat anticipator current	0.1 A, AC
Cad cell resistance (with flame)	R < 1500 OHMS
Agencies	UL recognized (US & Canada)

Installing and wiring

Warning — The 50200 control must be installed and serviced only by a qualified service technician.

- Always disconnect power source before wiring to avoid electrical shock or damage to the control. All wiring must comply with applicable codes and ordinances.
- Thermostat terminals (T-T) provide a current source. Never apply external power to these terminals under any circumstances.
- Alarm terminals provide a 24 VAC/VDC-rated dry contact, suitable for use with security/fire alarm systems such as Carlin Secure Heat™.

Mounting

- The control may be mounted on a 4" x 4" junction box in any convenient location on the burner, furnace or wall. The location must not exceed the ambient temperature limit, 140°F.

Wiring

- Wiring must comply with local and national electrical codes, and with the wiring diagram.

Field checks

- Safety timing (TFI) test** — Remove one cad cell wire (F-F). Start burner. The control should lockout within the TFI time limit. Replace cad cell wire.
- Flame failure test** — Start burner. After flame is established (after TFI period), close the oil supply hand valve. This will cause a flame failure sequence as described on the reverse side of this Data sheet. The control should recycle (restart after 65 seconds).
- If control does not operate as described, check the wiring.

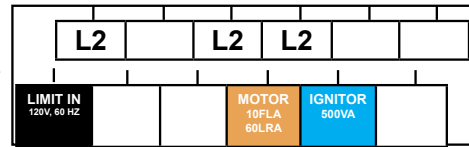

Start-up & operation



Do not start the burner if the combustion chamber contains oil or oil vapor.



Per UL requirements, the control will not turn on if the cad cell senses flame during the self-test. If the cad cell sees light (flame) at the beginning of a cycle, the control will remain in self-test mode until the cad cell no longer senses light (flame). The amber LED will blink momentarily every 3 to 4 seconds and green LED will be on or blinking.

Model 50200 diagnostic LED's

- | | | |
|---------------|--------------|--------------------|
| Ⓐ – Amber OFF | Ⓐ – Amber ON | Ⓐ – Amber FLASHING |
| Ⓒ – Green OFF | Ⓒ – Green ON | Ⓒ – Green FLASHING |
| Ⓡ – Red OFF | Ⓡ – Red ON | Ⓡ – Red FLASHING |

- ⒶⓇⓇ **Power ON** Open all manual oil line valves. Close the line switch. (If Red LED turns on constant Ⓡ, control is in lockout. See below to reset.)

- ⒶⓇⓇ **Self-test 1** The control performs a "boot-up" test to verify internal operation each time power is applied to the black wire. The amber LED turns on and the test continues for about 5 seconds. If the test fails, the control turns the amber LED off and repeats this test sequence until successful.

- ⒶⓇⓇ **Stand-by** Thermostat circuit open and/or limit circuit open) If Self-test 1 is successful, amber LED turns off and control waits for thermostat circuit to close and a limit input.

- ⒶⓇⓇ **Call for heat** Set thermostat to call for heat. Thermostat circuit must be closed and black wire must receive power from the limit circuit.

- Self-test 2** If a failure occurs in this self-check, the control won't start and the amber LED blinks 1 second on, 4 seconds off, until serviced or the problem clears. These failures include CAD cell seeing light, internal failure, or line voltage <90V. See service section.

- ⒶⓇⓇ **Burner on** After the self-test, amber LED turns off. The ignitor starts, followed 2 seconds later by the motor.

Understanding the Oil Primary Control (CB-350-CTB & CB-500-CTB) Cont.

Model 50200 Cad Cell Oil Primary Control Data Sheet

Start-up & operation continued...

C77012

Pump Prime To enter pump prime: 1. Start a CFH cycle. During Pre-Ignition or Pre-Purge, press Reset until motor turns off (10 seconds), then release the button. When motor turns back on, within 5 seconds, press the Reset button until the amber LED starts to flash. You are in Pump Prime, release Reset button.

Optional Pump Prime notes: 1) If lost, press Reset for 1 second and release, then if the control is not in Pump Prime, restart the sequence. 2) If Reset is released before end of first 10 seconds, the control returns to Standby and restarts another CFH cycle. 3) If reset is not pressed the second time, a normal CFH cycle will continue. 4) If motor and igniter are on and amber LED is flashing, the control is in Pump Prime. 5) Pump Prime will exit standby if flame is detected, or 60 seconds has elapsed, or loss of TT or Limit, or Reset button is pressed.

TFI The cad cell must sense flame within the TFI time limit (trial for ignition). After CAD cell senses flame, the ignitor stays on another 10 seconds. (flame stabilization period).

Run The burner continues firing during call for heat if the CAD cell is sensing flame. Only the green LED is on during normal running.

Lockout If cad cell does not sense flame within the TFI time limit after the burner starts, **lockout** occurs. The control turns the red LED on constant, and closes the alarm contact.

To Reset Push in and hold reset button for 1 second, then release.

Latch-up If the control locks out 3 times during a single call for heat, latch-up occurs. The control turns on both the amber and red LED's constant. You must use the special procedure below to reset the control after latch-up.



WARNING Reset after latch-up- only a qualified service technician should attempt to reset the control after latchup. The problem that caused the repeated burner lockouts must be corrected before returning the burner to normal operation.

Push in and hold the reset button for 10 seconds. The amber LED will begin to flash.

After the LED begins flashing, continue holding the reset button for 20 seconds. The LED's will turn off. Release the reset button and the control will restart (releasing the button before the LED's turn off will cause the control to remain in latch-up).

NOTICE

The 50200 control will not reset from lockout or latch-up if power is interrupted.

Flame failure If the CAD cell loses flame signal during operation (after the TFI), the red LED flashes. The burner shuts off within 2 seconds. **Recycle:** Control waits for 65 seconds (with red LED flashing), then begins again at Self-test. Red LED goes off.

End cycle Set thermostat (or aquastat) to stop call for heat. The burner shuts off within 2 seconds after end of call for heat.

Stand-by Control remains in stand-by mode until limit circuit sends power to the black wire and thermostat circuit closes (call for heat).

Service & Troubleshooting

Burner (control) will not come on

No power to control

- Check limit circuit to the control (at least 102 VAC).
- Check all electrical connections.

Control is in lockout

- Red LED will be on. Press the reset button for 1 second.
- If the control returns immediately to lockout, the Safety Monitoring Circuit may have detected an internal control problem. Replace the control.

CAD cell seeing light

- Green LED on, and amber LED blinking 1 second on, 4 seconds off. Remove one yellow lead from FF terminals, and the flame test plug. If the amber LED remains flashing, the control is defective. If the amber LED goes OFF, the control is OK, and;
 - light is leaking into the burner housing, *OR*
 - CAD cell is defective, *OR*
 - there is a problem with the CAD cell wiring or holder.
- If appliance was recently shut down, CAD cell may see residual hot spots in chamber.

To troubleshoot:

 - Attach multimeter to monitor CAD cell resistance. Dark resistance should be over 50K ohms, and room light resistance (control flipped open) should be at most 10K ohms. Replace cell if necessary, or reinstall and close the burner housing.
 - Check for stray light by measuring the CAD cell resistance looking into the inactive combustion chamber. It should read at least 50 K_{OHMS}.

Repeated flame failures (flashing red LED)

Check for:

- CAD cell is defective. Replace.
- Air leaking into oil line causing flame out- check oil line connections and filter gasket.
- Defective nozzle causing flame to be erratic- change nozzle.
- Excessive airflow or draft causing flame to leave burner head- check for proper air band setting and draft.
- Excessive back pressure causing flame to be erratic- check appliance and flue for sooting/plugging.

Control locks out after TFI (red LED on)

Check for:

- No oil to burner- check oil supply, filters, lines.
- Shorted electrodes- inspect for cracked porcelain and replace as needed.
- Poor spark- check electrode spacing and condition per burner manual. Replace or realign if necessary.
- Nozzle clogged- replace nozzle.
- Airflow too high- check air band setting.
- Ignitor module defective- replace if no spark.
- CAD cell defective
- Oil valve (if used) stuck in closed position.
- Check wiring connections.

APPENDIX C

Boiler Service Record

Boiler Purchased: Date _____ From (name/phone) _____

Boiler Installed: Date _____ By (name/phone) _____

Boiler Inspected: Date _____ By (name/phone) _____

Note: Refer to Section 9 for Maintenance Instructions

<u>Draft Readings</u> (Date / Draft)		<u>Service Record</u> (Date / Initials of Technician)						
Burner	Stack	Canister Filter	Metering Pump	Check Valve and Screen	Chamber & Flues	Stack	Oil Tank	A.P.M.*

*A.P.M. is Annual Preventative Maintenance on the Burner (Burner Tune-up)

